

File: A203/21

Applicant: 2572486 Ontario Ltd

Address: 36 Creedmore Ct Kleinburg

Agent: M. Behar Planning & Design Ltd

Please note that comments and written public submissions received after the preparation of this Staff Report (up until noon on the last business day prior to the day of the scheduled hearing date) will be provided as an addendum.

Commenting Department	<input checked="" type="checkbox"/> Positive Comment	Condition(s) <input checked="" type="checkbox"/> <input checked="" type="checkbox"/>
	<input checked="" type="checkbox"/> Negative Comment	
Committee of Adjustment	<input checked="" type="checkbox"/>	
Building Standards	<input checked="" type="checkbox"/>	
Building Inspection		
Development Planning	<input checked="" type="checkbox"/>	<input checked="" type="checkbox"/>
Development Engineering	<input checked="" type="checkbox"/>	<input checked="" type="checkbox"/>
Parks, Forestry and Horticulture Operations	<input checked="" type="checkbox"/>	
By-law & Compliance	<input checked="" type="checkbox"/>	
Financial Planning & Development	<input checked="" type="checkbox"/>	
Fire Department		
TRCA		
CPR	<input checked="" type="checkbox"/>	
Region of York	<input checked="" type="checkbox"/>	
Alectra (Formerly PowerStream)	<input checked="" type="checkbox"/>	
Public Correspondence (see Schedule B)		

Adjournment History: N/A

Background History: N/A

Staff Report Prepared By: Pravina Attwala
 Hearing Date: Thursday , November 18, 2021

***Please note that additional comments may be received after the publication of the Staff Report. These comments will be processed as an addendum (see website for details).**



Minor Variance Application

Agenda Item: 10

A203/21

Ward: 1

Staff Report Prepared By: Pravina Attwala, Assistant Secretary Treasurer

Date & Time of Live Stream Hearing: Thursday , November 18, 2021 at 6:00 p.m.

As a result of COVID-19, Vaughan City Hall and all other City facilities are closed to the public at this time.

A live stream of the meeting is available at Vaughan.ca/LiveCouncil

Please submit written comments by mail or email to:

City of Vaughan
Office of the City Clerk – Committee of Adjustment
2141 Major Mackenzie Drive, Vaughan, ON L6A 1T1
cofa@vaughan.ca

To make an electronic deputation at the meeting please contact the Committee of Adjustment at cofa@vaughan.ca or 905-832-8504. Ext. 8332

Written comments or requests to make a deputation must be received by noon on the last business day before the meeting.

- Applicant:** 2572486 Ontario Ltd
- Agent:** M. Behar Planning & Design Ltd
- Property:** 36 Creedmore Ct Kleinburg
- Zoning:** The subject lands are zoned RD1, Residential and subject to the provisions of Exception 9(1316) under By-law 1-88 as amended.
- OP Designation:** Vaughan Official Plan 2010 ('VOP 2010'): "Low-Rise Residential"
- Related Files:** None
- Purpose:** Relief from By-law 1-88, as amended, is being requested to permit the construction of a proposed single family dwelling.

The following variances are being requested from By-Law 1-88, as amended, to accommodate the above proposal:

By-law Requirement	Proposal
1. No garage shall project into the front yard or exterior yard more than 1.0 metre beyond the most distant point of any wall of the dwelling facing the street at the ground floor level and a maximum of 2.0 metres where there is a covered and unenclosed porch. [General Notes, Schedule A3]	1. To permit a maximum garage projection of 10.72 metres.
2. A maximum building height of 11 metres is permitted. [Schedule A3]	2. To permit a maximum height of 12. 74 metres for a dwelling.
3. Minimum interior garage dimensions 5.5 metres width x 6.0 metres length are required. [General Notes, Schedule A3]	3. To permit a garage with minimum interior garage dimensions of 7.01 metres width x 5.79 metres length .

Background (previous applications approved by the Committee on the subject land): N/A

For information on the previous approvals listed above please visit www.vaughan.ca. To search for a file number, enter it using quotes around it. For example, "A001/17".

To search property address, enter street number and street name using quotes. For example, "2141 Major Mackenzie". Do not include street type (i.e. drive).

Adjournment History: N/A

Staff & Agency Comments

Please note that staff/agency comments received after the preparation of this Report will be provided as an addendum item to the Committee. Addendum items will shall only be received by the Secretary Treasurer until **noon** on the last business day **prior** to the day of the scheduled Meeting.

Committee of Adjustment:

Public notice was mailed on November 3, 2021

Applicant confirmed posting of signage on November 2, 2021

Property Information	
Existing Structures	Year Constructed
Dwelling	Purchased 2017

Applicant has advised that they cannot comply with By-law for the following reason(s):
To design a custom home within an approved plan of subdivision, variances are required to specific performance standards.

Committee of Adjustment recommended conditions of approval: None

Building Standards (Zoning Review):

Stop Work Order(s) and Order(s) to Comply: There are no outstanding Orders on file.

Building Permit No. 20-000479 for Single Detached Dwelling - New, (Not Yet Issued)

Building Permit No. 20-000480 for Shed/Gazebo - New, (Not Yet Issued)

A permit from the Engineering Department is required for the proposed private swimming pool.

1. The applicant shall be advised that additional variances may be required upon review of detailed drawing for building permits.
2. Please note Section 4.1.1(b) that states the maximum height of an accessory building or structure measured from the average finished ground level to the highest point of the said building or structure shall be 4.5 metres. The nearest part of the roof shall not be more than three (3) metres above finished grade.
3. Should the pool equipment not be housed in the pool cabana,,:
 - h) Notwithstanding the yard requirements of this By-law, the following shall be permitted in any required side yard or rear yard of residential lots:

External Ground-Mounted

- i) Central Air Conditioner and/or Heat Pump Units shall be permitted in the interior side yard with a minimum setback of 0.6 metres.
- ii) Central Air Conditioner and/or Heat Pump Units are permitted to encroach a maximum of 1.5 metres into the required rear yard, and exterior side yard, provided that the encroachment only occurs on yards having flankage on local roads.

External Wall – Mounted

- i) Central Air Conditioner Units shall be permitted in the interior side yard having a minimum setback of 0.3 metres.
- ii) Central Air Conditioner Units are permitted to encroach a maximum of 1.5 metres into the required rear yard, and exterior side yard, provided that the encroachment only occurs on yards having flankage on local roads.

Building Inspections (Septic):

No comments received to date

Development Planning:

Please see Schedule C for Development Planning comments/conditions.

Development Engineering:

As the proposed structures in the subject property is 410.7 m², the owner/ applicant needs to obtain a lot grading permit from Development Inspection and Lot Grading division of the City's Development Engineering Department. Please note any in ground structure over 10 m² requires a grading permit. Please contact COA application engineering reviewer after receiving the grading permit to clear the condition. (Condition attached)

The Owner/applicant shall apply for a pool permit with the Development Engineering (DE) Department. Please visit or contact the Development Engineering Department through email at DEPermits@vaughan.ca or visit https://www.vaughan.ca/services/residential/dev_eng/permits/Pages/default.aspx to learn how to apply for the pool permit.

The owner/applicant shall apply and obtain the necessary curb cut/ reinstating permit through the Transportation and Fleet Management Services. Please visit https://www.vaughan.ca/services/residential/transportation/roads/curb_cuts_and_driveway_widening/Pages/default.aspx to learn how to apply for the curb cut/ reinstating permit.

The Development Engineering (DE) Department does not object to variance application A203/21 subject to the following condition(s):

The Owner/applicant shall submit the final Lot Grading and/or Servicing Plan to the Development Inspection and Lot Grading division of the City’s Development Engineering Department for final lot grading and/or servicing approval prior to any work being undertaken on the property. Please visit or contact the Development Engineering Department through email at DEPermits@vaughan.ca or visit https://www.vaughan.ca/services/residential/dev_eng/permits/Pages/default.aspx to learn how to apply for lot grading and/or servicing approval.

Parks Development - Forestry:
No comments no concerns.

By-Law and Compliance, Licensing and Permit Services:
No comments no concerns.

Development Finance:
No comment no concerns

Fire Department:
No comments received to date

Schedule A – Plans & Sketches

Schedule B – Public Correspondence
None

Schedule C - Development Planning & Agency Comments
Development Planning Comments
Alectra (Formerly PowerStream) – No concerns or objections
Region of York – No concerns or objections
CPR – comments with guidelines

Schedule D - Previous Approvals (Notice of Decision)
None

Staff Recommendations:
Staff and outside agencies (i.e. TRCA) act as advisory bodies to the Committee of Adjustment. Comments received are provided in the form of recommendations to assist the Committee.

The Planning Act sets the criteria for authorizing minor variances to the City of Vaughan’s Zoning By-law. Accordingly, review of the application considers the following:

- ✓ That the general intent and purpose of the by-law will be maintained.
- ✓ That the general intent and purpose of the official plan will be maintained.
- ✓ That the requested variance(s) is/are acceptable for the appropriate development of the subject lands.
- ✓ That the requested variance(s) is/are minor in nature.

Should the Committee **adjourn** this application the following condition(s) is required: N/A

Should the Committee find it appropriate to approve this application in accordance with request and the sketch submitted with the application as required by Ontario Regulation 200/96, the following conditions have been recommended:

	Department/Agency	Condition
1	Development Planning Michael Torres 905-832-8585 x 8933 Michael.Torres@vaughan.ca	The Owner shall provide a letter from the Control Architect that confirms there are no concerns with the proposed development.

2	Development Engineering Farzana Khan 905-832-8585 x 3608 Farzana.Khan@Vaughan.ca	The Owner/applicant shall submit the final Lot Grading and/or Servicing Plan to the Development Inspection and Lot Grading division of the City's Development Engineering Department for final lot grading and/or servicing approval prior to any work being undertaken on the property. Please visit or contact the Development Engineering Department through email at DEPermits@vaughan.ca or visit https://www.vaughan.ca/services/residential/dev_eng/permits/Pages/default.aspx to learn how to apply for lot grading and/or servicing approval.
---	--------------------------------------------------------------------------------------------------------------------------------------------	-----------------------------------------------------------------------------------------------------------------------------------------------------------------------------------------------------------------------------------------------------------------------------------------------------------------------------------------------------------------------------------------------------------------------------------------------------------------------------------------------------------------------------------------------------------------------------------------------------------------------------------------------------------------------------------------------

Conditions

It is the responsibility of the owner/applicant and/or authorized agent to obtain and provide a clearance letter from respective department and/or agency. This letter must be provided to the Secretary-Treasurer to be finalized. All conditions must be cleared prior to the issuance of a Building Permit.

Please Note:

Relief granted from the City's Zoning By-law is determined to be the building envelope considered and approved by the Committee of Adjustment.

Development outside of the approved building envelope (subject to this application) must comply with the provisions of the City's Zoning By-law or additional variances may be required.

Elevation drawings are provided to reflect the style of roof to which building height has been applied (i.e. flat, mansard, gable etc.) as per By-law 1-88 and the Committee of Adjustment approval. Please note, that architectural design features (i.e. window placement), that do not impact the style of roof approved by the Committee, are not regulated by this decision.

Notice to the Applicant – Development Charges

That the payment of the Regional Development Charge, if required, is payable to the City of Vaughan before issuance of a building permit in accordance with the Development Charges Act and the Regional Development Charges By-law in effect at the time of payment.

That the payment of the City Development Charge, if required, is payable to the City of Vaughan before issuance of a building permit in accordance with the Development Charges Act and the City's Development Charges By-law in effect at the time of payment.

That the payment of the Education Development Charge if required, is payable to the City of Vaughan before issuance of a building permit in accordance with the Development Charges Act and the Boards of Education By-laws in effect at the time of payment

That the payment of Special Area Development charge, if required, is payable to the City of Vaughan before issuance of a building permit in accordance with the Development Charges Act and The City's Development Charge By-law in effect at the time of Building permit issuance to the satisfaction of the Reserves/Capital Department.

Notice to Public

PLEASE NOTE: As a result of COVID-19, Vaughan City Hall and all other City facilities are closed to the public at this time.

PUBLIC CONSULTATION DURING OFFICE CLOSURE: Any person who supports or opposes this application, but is unable to attend the hearing, may make a written submission, together with reasons for support or opposition. Written submissions on an Application shall only be received until **noon** on the last business day **prior** to the day of the scheduled hearing. Written submissions can be mailed and/or emailed to:

City of Vaughan
Office of the City Clerk – Committee of Adjustment
2141 Major Mackenzie Drive, Vaughan, ON L6A 1T1
cofa@vaughan.ca

ELECTRONIC PARTICIPATION: During the COVID-19 emergency, residents can view a live stream of the meeting Vaughan.ca/LiveCouncil. To make an electronic deputation, residents must complete and submit a [Public Deputation Form](#) no later than **noon** on the last business prior to the scheduled hearing. To obtain a Public Deputation Form please contact our office or visit www.vaughan.ca

Presentations to the Committee are generally limited to 5 minutes in length. Please note that Committee of Adjustment meetings may be audio/video recorded. Your name, address comments and any other personal information will form part of the public record pertaining to this application.

PUBLIC RECORD: Personal information is collected under the authority of the Municipal Act, the Municipal Freedom of Information and Protection of Privacy Act (MFIPPA), the Planning Act and all other relevant legislation, and will be used to assist in deciding on this matter. All personal information (as defined by MFIPPA), including (but not limited to) names, addresses, opinions and comments collected will become property of the City of Vaughan, will be made available for public disclosure (including being posted on the internet) and will be used to assist the Committee of Adjustment and staff to process this application.

NOTICE OF DECISION: If you wish to be notified of the decision in respect to this application or a related Ontario Land Tribunal (OLT) hearing you must complete a Request for Decision form and submit to the Secretary Treasurer (ask staff for details). In the absence of a written request to be notified of the Committee's decision you will **not** receive notice.

For further information please contact the City of Vaughan, Committee of Adjustment

T 905 832 8585 Extension 8002
E CofA@vaughan.ca

Schedule A: Plans & Sketches

Please note that the correspondence listed in Schedule A is not comprehensive. Plans & sketches received after the preparation of this staff report will be provided as an addendum.

Location Map
Plans & Sketches



LOCATION MAP A203/21

36 CREEDMORE COURT, KLEINBURG

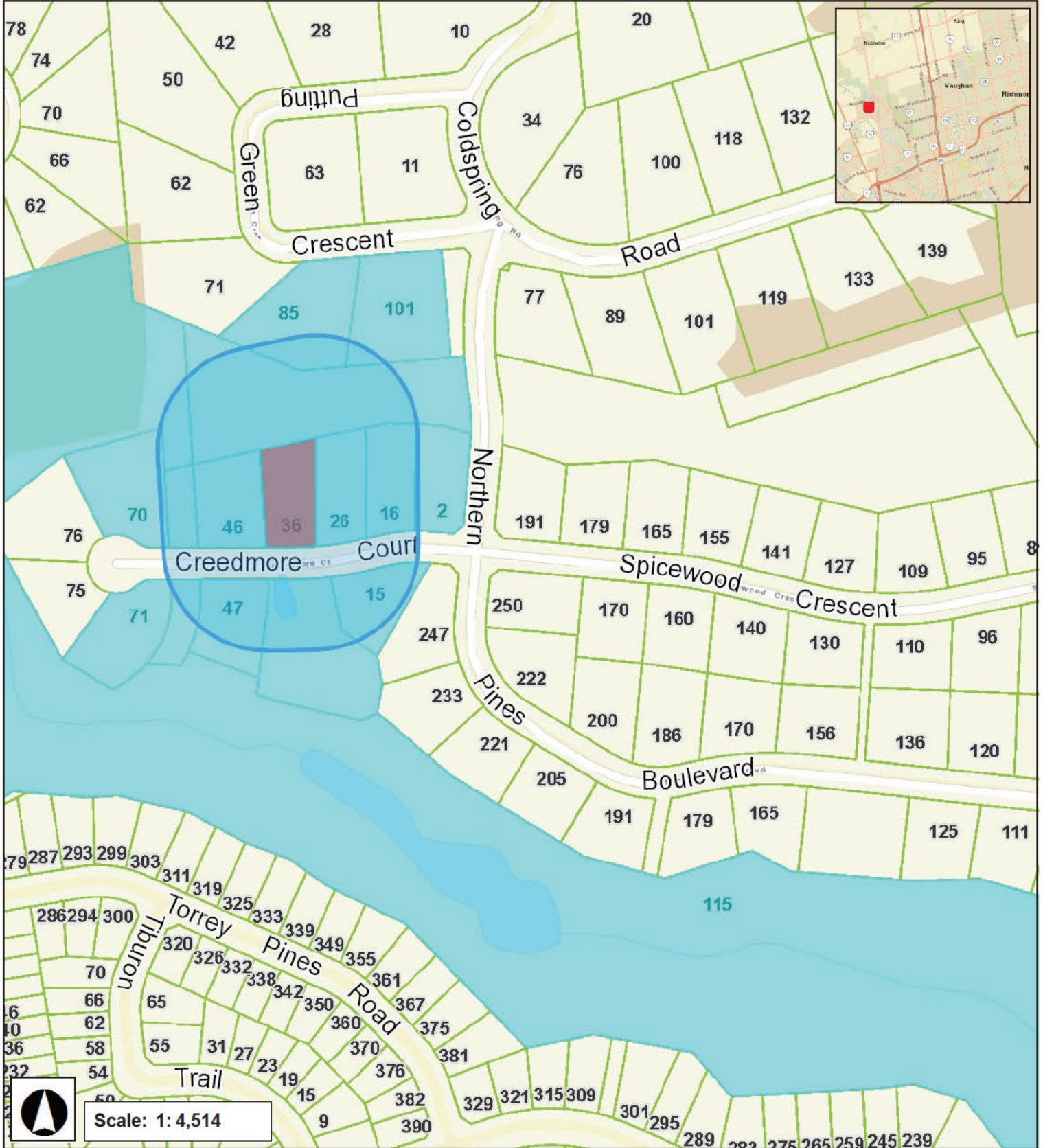

36 (LOT 24) CREEDMORE CRT.

COMMITTEE OF ADJUSTMENT

SITE STATISTICS ZONING BYLAW SUMMARY

ZONING	RDI - EX. 1316	
COVERAGE	N/A	
DENSITY	N/A	
HEIGHT	11.0M	
SETBACKS	FRONT	4.5M
	REAR	7.5M
	SIDE	1.2M
LOT AREA:	23743.76 SF	2205.80 M2
PROP. GFA:		
GROUND FLOOR:	4,420 S.F.	410.70 M2
SECOND FLOOR:	1,439 S.F.	133.68 M2
TOTAL GFA:	5,859 S.F.	544.38 M2
FIN. BASEMENT AREA:	4,371 S.F.	406.12 M2
BLDG. COVERAGE:	5,658 S.F.	525.69 M2
* INCL. FRONT PORCH / EXCL. LOGGIA, FRONT PORCH STEPS, BASEMENT WALKOUT		
LOT COVERAGE:	23.83%	
PROP. HEIGHT:	12.74M	
PROP. BLDG. LENGTH:	AS SHOWN	
INDOOR PARKING:	4	

FRONT YARD	(A)	TOTAL FRONT YARD AREA	333.07 M2
	(B)	DRIVEWAY AREA + PAVED PATIO	68.30 M2
	(C)	TOTAL SOFT LANDSCAPED AREA	263.39 M2

REAR YARD	(A)	TOTAL REAR YARD AREA	838.61 M2
	(B)	REAR SOFT L'SCAPED AREA PROVIDED	502.97 M2
	MIN. SOFT LANDSCAPED AREA REQUIRED:		(838.61 M2- 135 M2) X 60%= 422.16 M2

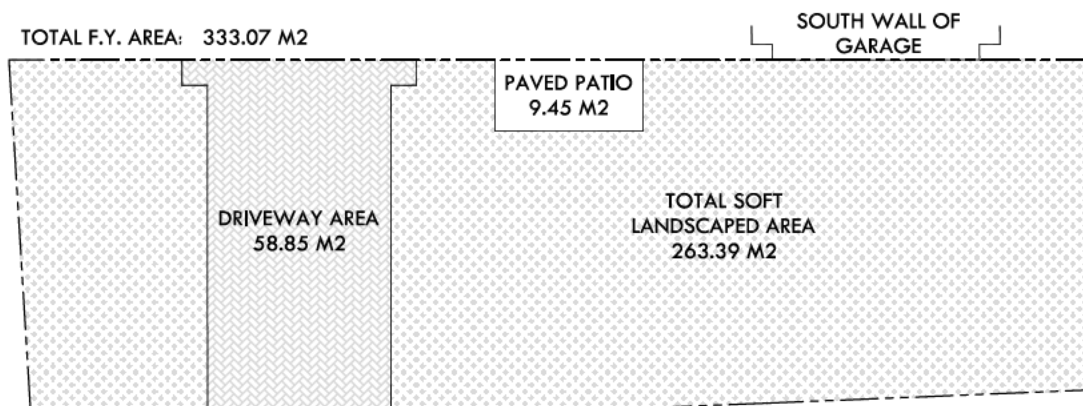

Zanjani Architect Inc.

15 Allstate Pkwy, Unit 664
Markham, ON L3R 5B4
T: 416.917.8285
E: info@zanjaniarchitect.com

06	FOR C.O.A. RESUBMISSION	JUN. 08, 2021	S.Z.
05	FOR C.O.A. RESUBMISSION	DEC. 22, 2020	S.Z.
04	FOR C.O.A. SUBMISSION	NOV. 27, 2020	S.Z.
ITEMS 1-3 NOT SHOWN			
Issued:			

A0

PROPOSED 1.5-STOREY DWELLING 36 (LOT24) CREEDMORE CRT.
KLEINBURG, ON

STATS
SCALE: N/A

BLOCK 75
PIN 03322-0359
(PARK)

PARKLAND

LOT 24,

CONCESSIO

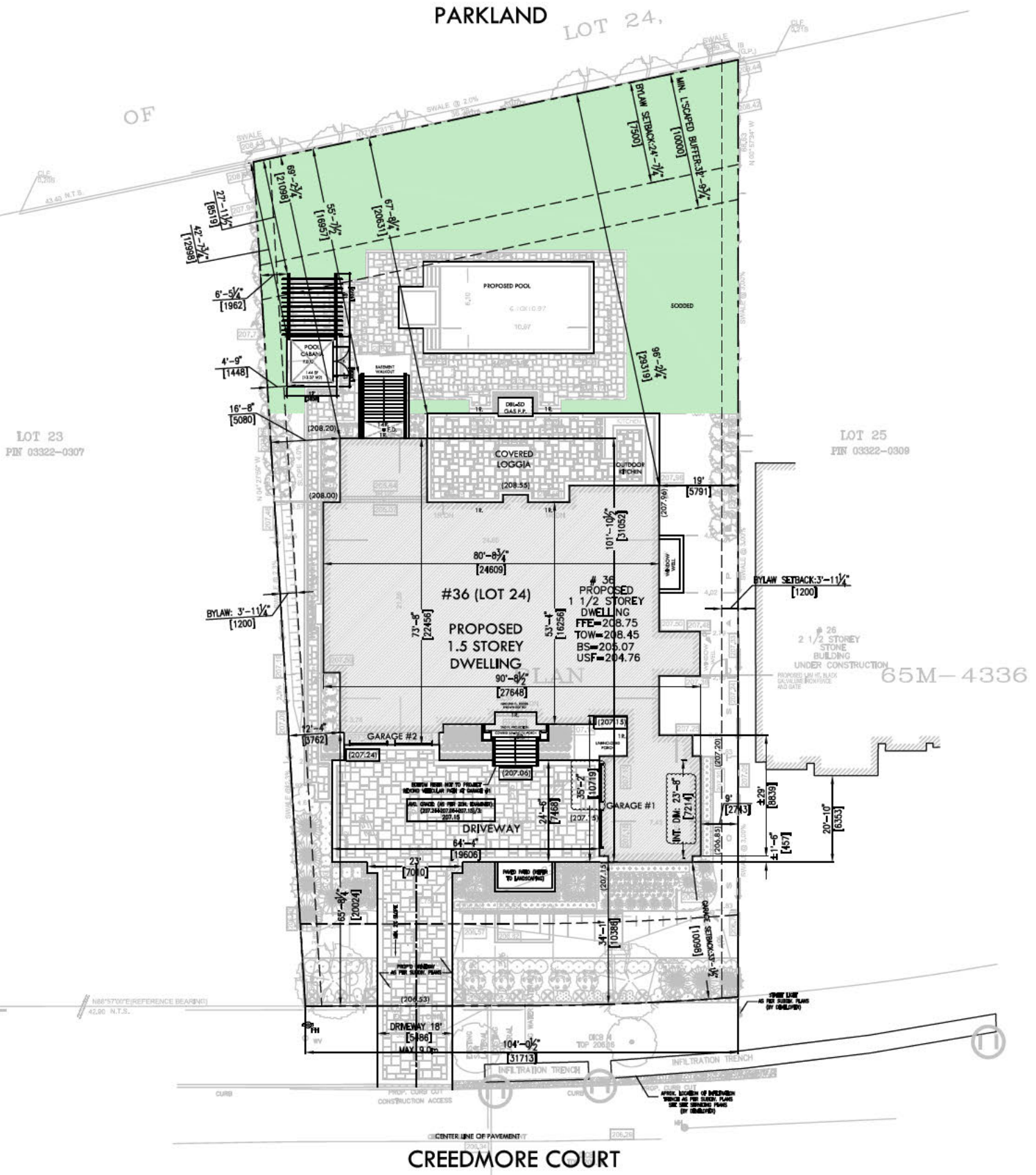

LOT 23
PIN 03322-0307

LOT 25
PIN 03322-0309

65M-4336

CREEDMORE COURT

Zanjani Architect Inc.
15 Allstate Pkwy, Unit 664
Markham, ON L3R 5B4
T: 416.917.8285
E: info@zanjaniarchitect.com

06	FOR C.O.A. RESUBMISSION	JUN. 08. 2021	S.Z.
05	FOR C.O.A. RESUBMISSION	DEC. 22, 2020	S.Z.
04	FOR C.O.A. SUBMISSION	NOV. 27, 2020	S.Z.
ITEMS 1-3 NOT SHOWN			
Issued:			



A1

PROPOSED 1.5-STOREY DWELLING 36 (LOT24) CREEDMORE CRT.
KLEINBURG, ON

SITE PLAN
SCALE: 1/32"=1'-0"

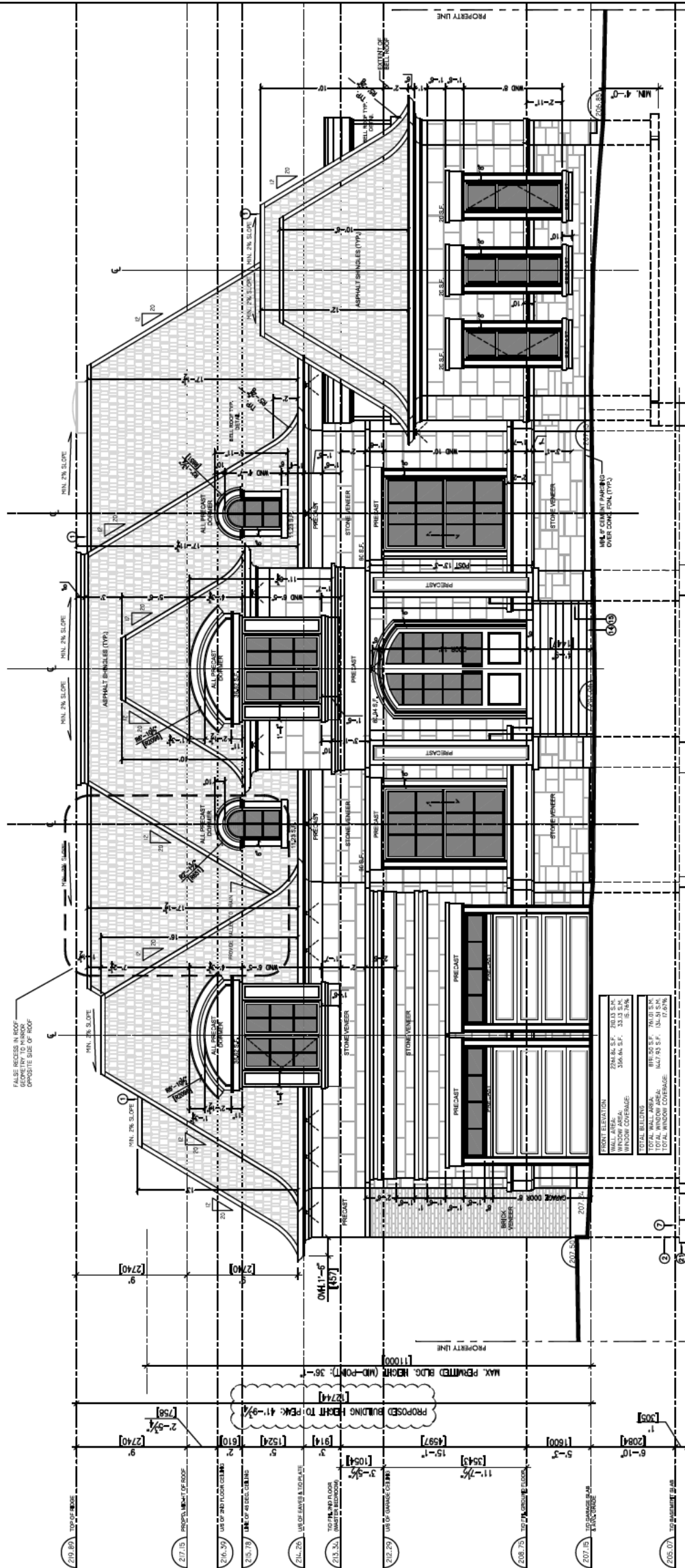

Zanjani Architect Inc.
 15 Allstate Pkwy, Unit 664
 Markham, ON L3R 5B4
 T: 416.917.8285
 E: info@zanjaniarchitect.com

05	FOR C.O.A. RESUBMISSION	JUN. 08. 2021	S.Z.
04	FOR C.O.A. SUBMISSION	NOV. 27. 2020	S.Z.
03	FOR SIGNOFF. GARAGE + BLDG. HT. REV.	NOV. 25. 2020	S.Z.
02	RE-ISSUED FOR C.O.A.	MAY. 02. 2020	S.Z.
01	FOR C.O.A.	APR. 12. 2020	S.Z.

A6

PROPOSED 1.5-STOREY DWELLING

36 (LOT24) CREEDMORE CRT.
 KLEINBURG, ON

FRONT (SOUTH) ELEVATION
 SCALE: 3/32"=1'-0"

COPYRIGHT 2020 ZANJANI ARCHITECT INC.

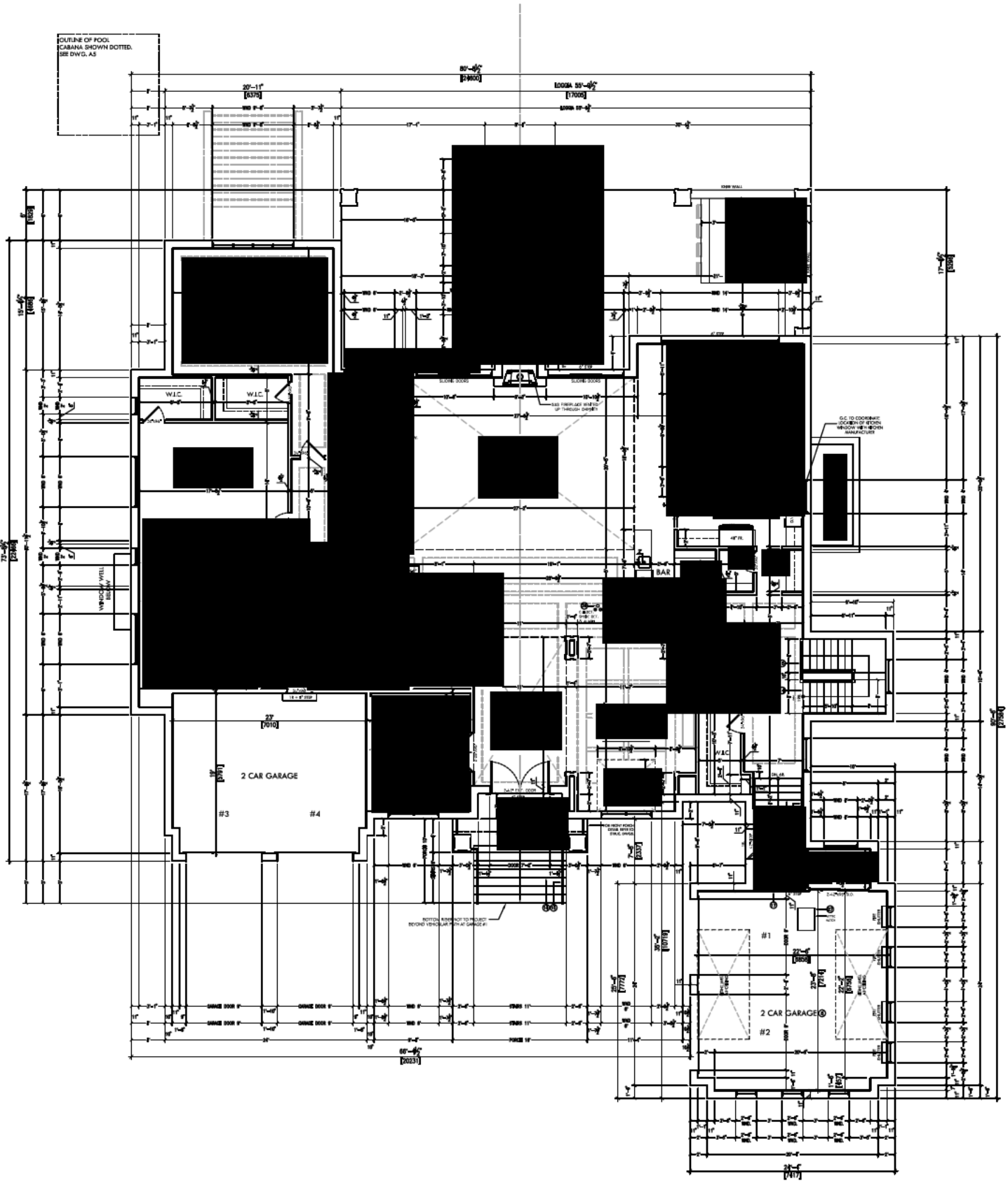

Zanjani Architect Inc.
 15 Allstate Pkwy, Unit 664
 Markham, ON L3R 5B4
 T: 416.917.8285
 E: info@zanjaniarchitect.com

05	FOR C.O.A. RESUBMISSION	JUN. 08. 2021	S.Z.
04	FOR C.O.A. SUBMISSION	NOV. 27. 2020	S.Z.
03	FOR SIGNOFF GARAGE + BLDG. HT. REV.	NOV. 25. 2020	S.Z.
02	RE-ISSUED FOR C.O.A.	MAY. 02. 2020	S.Z.
01	FOR C.O.A.	APR. 12. 2020	S.Z.
Issued:			

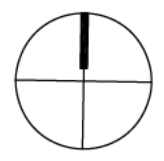

A3

PROPOSED 1.5-STOREY DWELLING 36 (LOT24) CREEDMORE CRT.
 KLEINBURG, ON

GROUND FLOOR PLAN
 SCALE: 1/16"=1'-0"

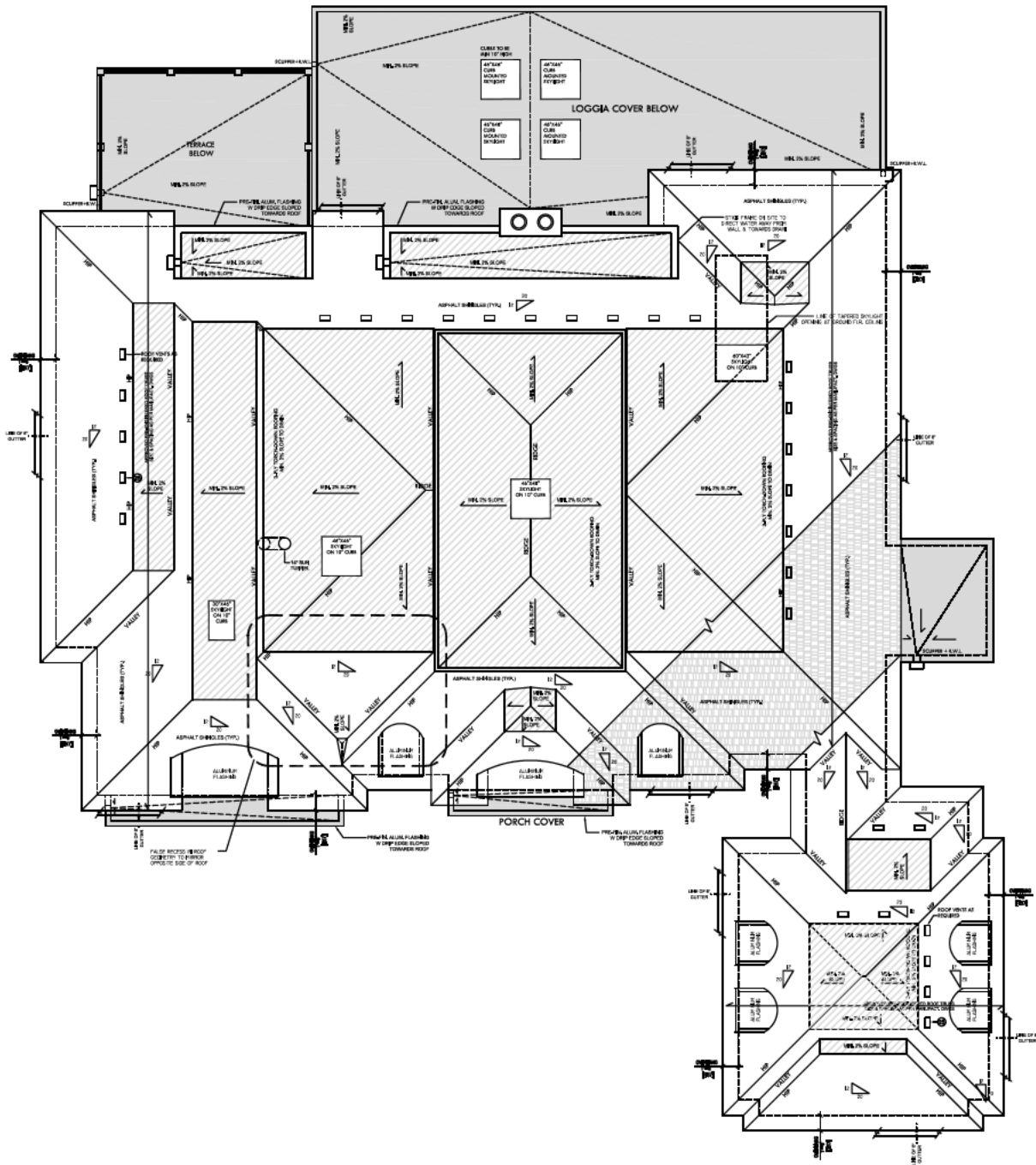

Zanjani Architect Inc.
 15 Allstate Pkwy, Unit 664
 Markham, ON L3R 5B4
 T: 416.917.8285
 E: info@zanjaniarchitect.com

05	FOR C.O.A. RESUBMISSION	JUN. 08. 2021	S.Z.
04	FOR C.O.A. SUBMISSION	NOV. 27. 2020	S.Z.
03	FOR SIGNOFF GARAGE + BLDG. HT. REV.	NOV. 25. 2020	S.Z.
02	RE-ISSUED FOR C.O.A.	MAY. 02. 2020	S.Z.
01	FOR C.O.A.	APR. 12. 2020	S.Z.
Issued:			

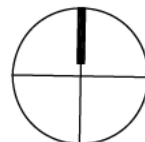

A5

PROPOSED 1.5-STOREY DWELLING

36 (LOT24) CREEDMORE CRT.
 KLEINBURG. ON

ROOF PLAN
 SCALE: 1/16"=1'-0"

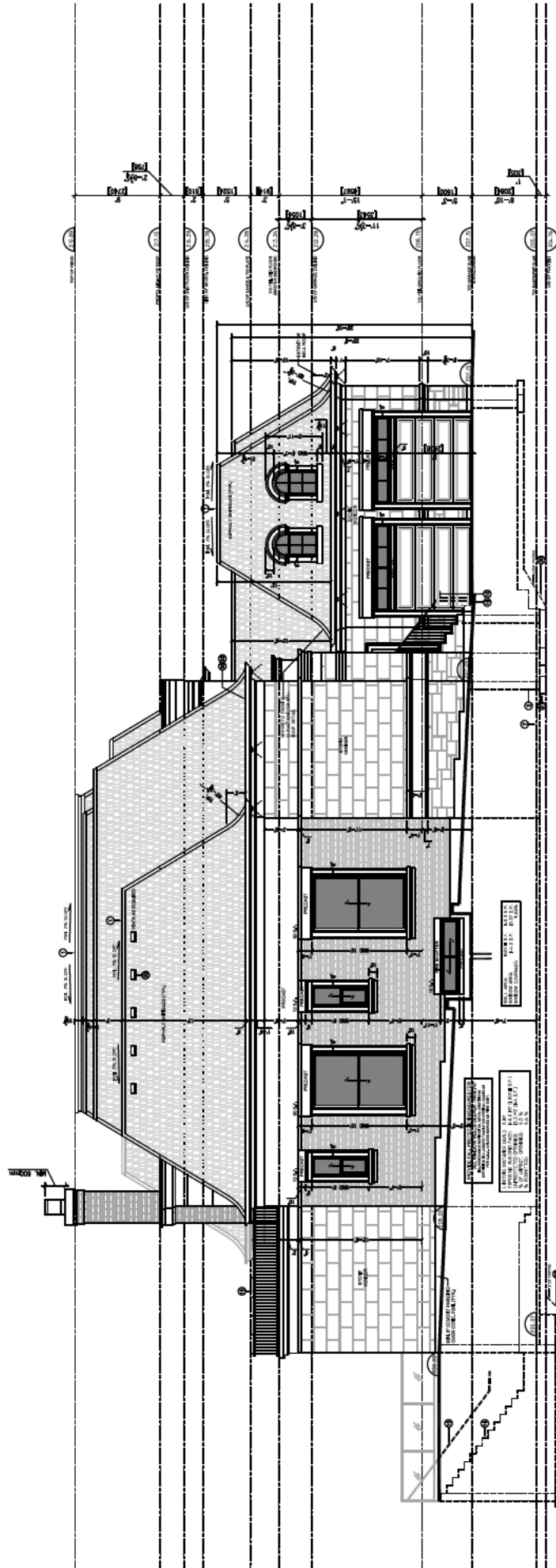

Zanjani Architect Inc.

15 Allstate Pkwy, Unit 664
 Markham, ON L3R 5B4
 T: 416.917.8285
 E: info@zanjaniarchitect.com

05	FOR C.O.A. RESUBMISSION	JUN. 08. 2021	S.Z.
04	FOR C.O.A. SUBMISSION	NOV. 27. 2020	S.Z.
03	FOR SIGNOFF GARAGE + BLDG. HT. REV.	NOV. 25. 2020	S.Z.
02	RE-ISSUED FOR C.O.A.	MAY. 02. 2020	S.Z.
01	FOR C.O.A.	APR. 12. 2020	S.Z.

Issued:

A7

PROPOSED 1.5-STOREY DWELLING

36 (LOT24) CREEDMORE CRT.
 KLEINBURG. ON

SIDE (WEST) ELEVATION
 SCALE: 1/16"=1'-0"

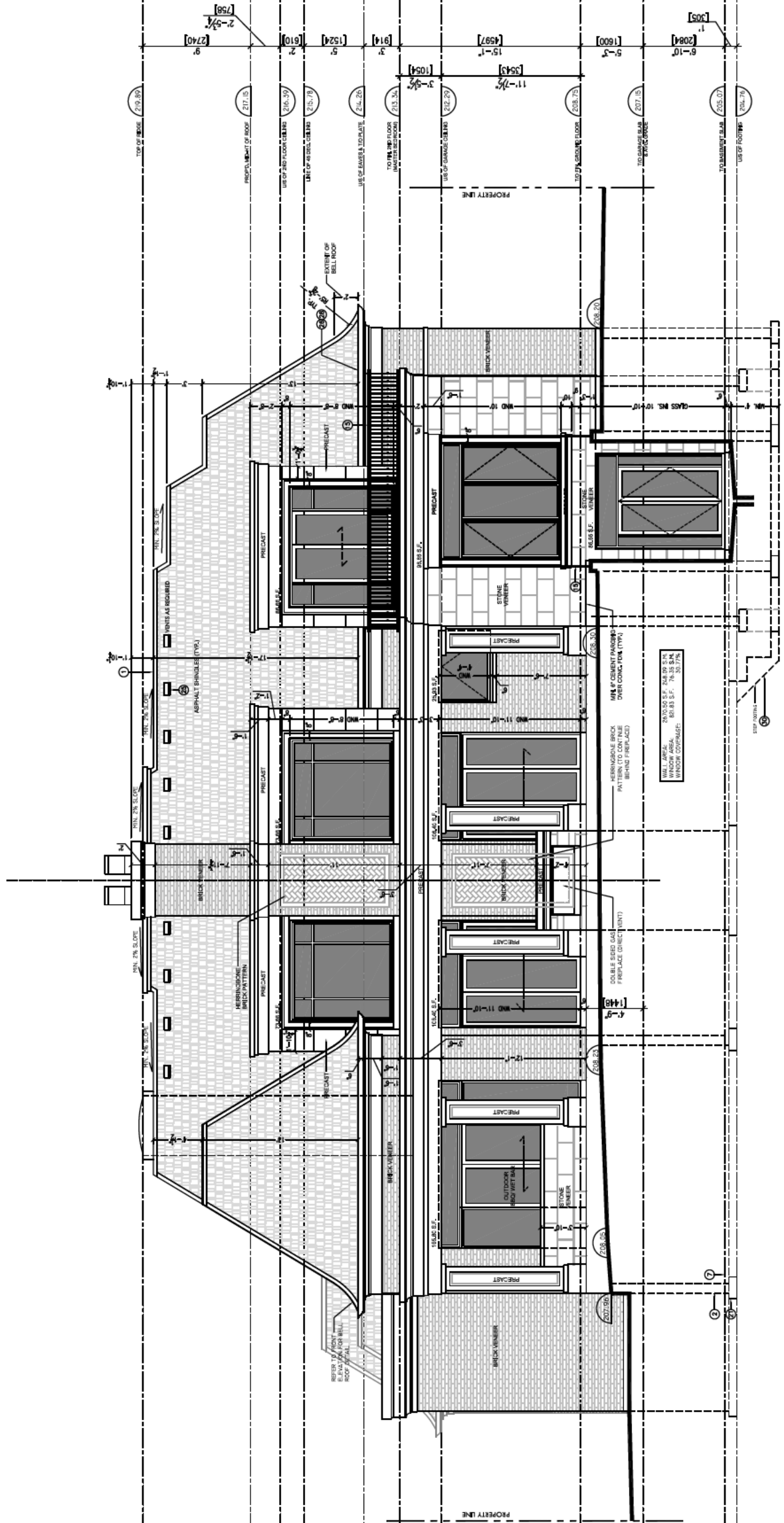

Zanjani Architect Inc.
 15 Allstate Pkwy, Unit 664
 Markham, ON L3R 5B4
 T: 416.917.8285
 E: info@zanjaniarchitect.com

05	FOR C.O.A. RESUBMISSION	JUN. 08. 2021	S.Z.
04	FOR C.O.A. SUBMISSION	NOV. 27. 2020	S.Z.
03	FOR SIGNOFF GARAGE + BLDG. HT. REV.	NOV. 25. 2020	S.Z.
02	RE-ISSUED FOR C.O.A.	MAY. 02. 2020	S.Z.
01	FOR C.O.A.	APR. 12. 2020	S.Z.
Issued:			

A8

PROPOSED 1.5-STOREY DWELLING

36 (LOT24) CREEDMORE CRT.
 KLEINBURG, ON

REAR (NORTH) ELEVATION
 SCALE: 3/32"=1'-0"

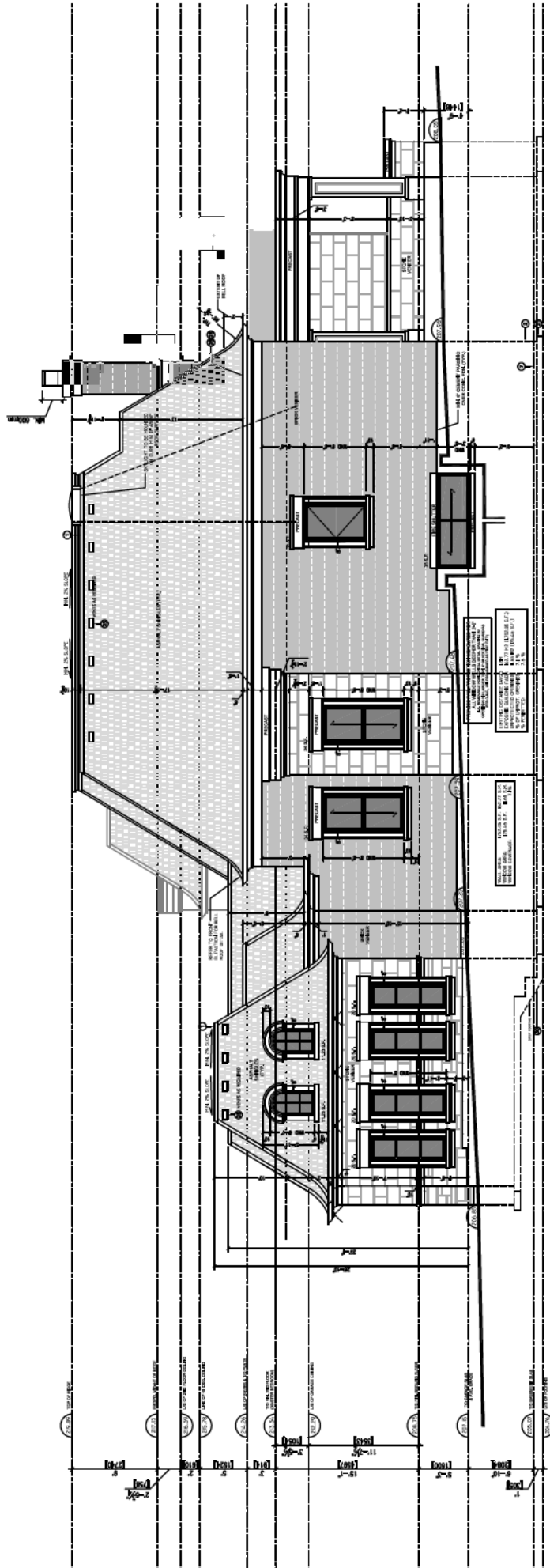

Zanjani Architect Inc.

15 Allstate Pkwy, Unit 664
 Markham, ON L3R 5B4
 T: 416.917.8285
 E: info@zanjaniarchitect.com

05	FOR C.O.A. RESUBMISSION	JUN. 08. 2021	S.Z.
04	FOR C.O.A. SUBMISSION	NOV. 27. 2020	S.Z.
03	FOR SIGNOFF GARAGE + BLDG. HT. REV.	NOV. 25. 2020	S.Z.
02	RE-ISSUED FOR C.O.A.	MAY. 02. 2020	S.Z.
01	FOR C.O.A.	APR. 12. 2020	S.Z.

Issued:

A9

PROPOSED 1.5-STOREY DWELLING

36 (LOT24) CREEDMORE CRT.
 KLEINBURG. ON

SIDE (EAST) ELEVATION
 SCALE: 1/16"=1'-0"

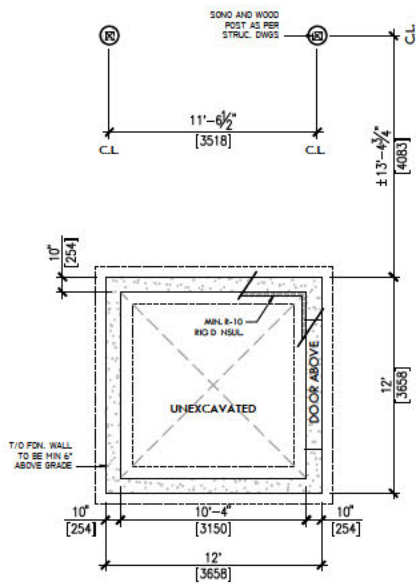

FOUNDATION PLAN

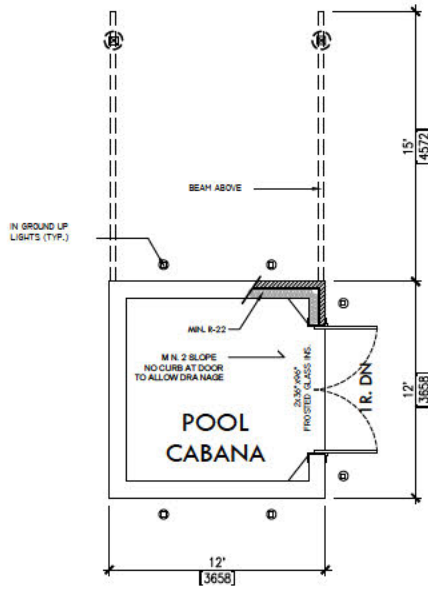

GROUND LEVEL

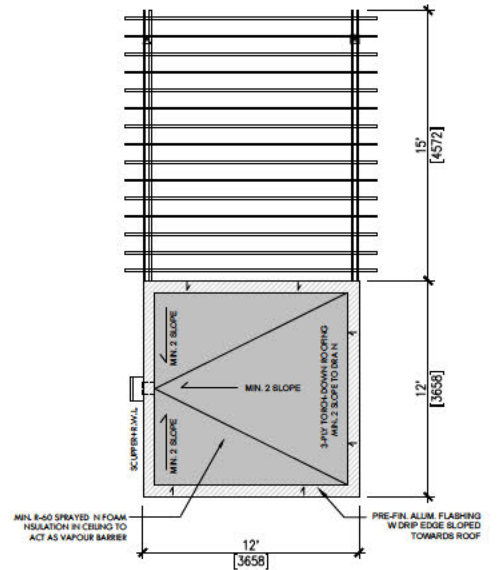

ROOF PLAN

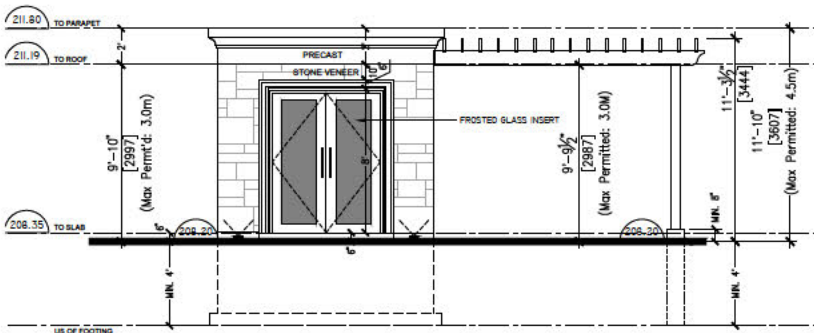

EAST ELEVATION

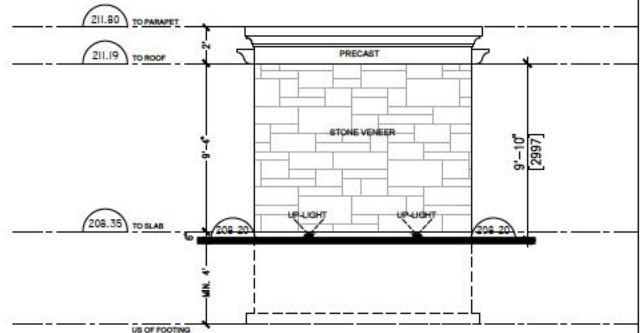

SOUTH ELEVATION

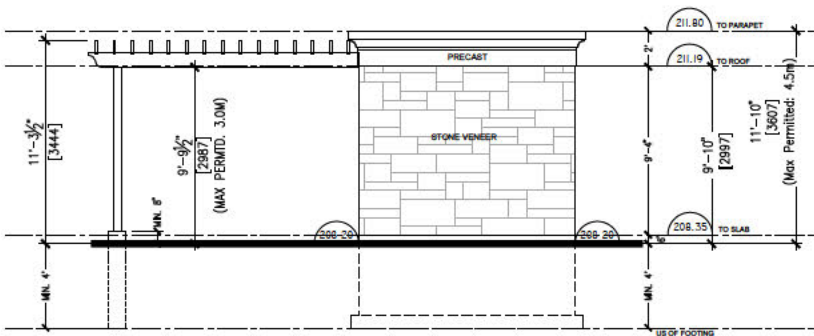

WEST ELEVATION

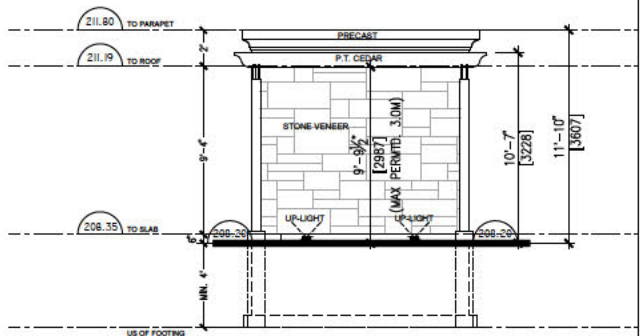

NORTH ELEVATION

Zanjani Architect Inc.
 15 Allstate Pkwy, Unit 664
 Markham, ON L3R 5B4
 T: 416.917.8285
 E: info@zanjaniarchitect.com

05	FOR C.O.A. SUBMISSION	NOV. 27. 2020	S.Z.
04	FOR SIGNOFF GARAGE + BLDG. HT. REV.	NOV. 25. 2020	S.Z.
03	RE-ISSUED FOR C.O.A.-REDUCED CABANA HT.	MAY. 11. 2020	S.Z.
02	RE-ISSUED FOR C.O.A.	MAY. 02. 2020	S.Z.
01	FOR C.O.A.	APR. 12. 2020	S.Z.
Issued:			

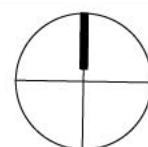

A11

PARKLAND

PROPOSED 1.8m HT BLACK VINYL FENCE BY DEVELOPER

RETAINING WALL: HEIGHT AS PER GRADING PLAN

PERGOLA OVER LOUNGE AREA
PATIO PAVING: MELVILLE PAVERS BY PERMACON

PROPOSED 1.8m HT BLACK GALVALUME IRON FENCE & GATE

SIDE WALKWAY

MELVILLE PAVER DRIVEWAY WITH BORDER

Key	Qty	Botanical Name	Common Name	Size/Condition
Trees				
Ca	5	Cornus alternifolia	PAGODA DOGWOOD	60 mm cal.
FaD	21	Fagus sylvatica 'Dawyc'	DAWYCK EUROPEAN BEECH	50 mm cal.
Ld	5	Larix laricina	COMMON LARCH	250 cm ht.
Lt	8	Liriodendron tulipifera	TULIP TREE	60 mm cal.
Fp	3	Rosa purgosa 'Blue Eyes'	BABY BLUE EYES SPRUCE	175 cm ht.
To	9	Thuja occidentalis	CEDAR	250 cm ht.
Shrubs				
BGV	53	Buxus 'Green Velvet'	GREEN VELVET BOXWOOD	2 Gal
Ca	19	Cornus stolonifera	RED OSIER DOGWOOD	80 cm
GaM	9	Cornus sanguinea 'Midwinter Fire'	MIDWINTER FIRE BLOODTWIG DOGWOOD	60 cm
DI	10	Diervilla lonicera	BUSH HONEYSUCKLE	80 cm
HmB	15	Hydrangea macrophylla 'Balmier'	ENDLESS SUMMER BIGLEAF HYDRANGEA	60 cm
HmB	7	Hydrangea macrophylla 'Blushing Bride'	BLUSHING BRIDE HYDRANGEA	60 cm
Hp	9	Hypericum prolificum	SHRUBBY ST. JOHNS WORT	60 cm
Hv	9	Hamamelis virginiana	WITCHHAZEL	80 cm
PoM	5	Physocarpus opulifolius 'Monio'	DIABOLO NINEBARK	60 cm
Pov	3	Physocarpus opulifolius var. 'parvifolius'	NINEBARK	80 cm
SCA	18	Sambucus canadensis 'Aurea'	AUREA AMERICAN ELDERBERRY	80 cm
SM	2	Syringa meyeri 'Miss Kim' Std.	STANDARD DWARF KOREAN LILAC	60 cm
TmH	31	Taxus x media 'Hicksii'	HICKS YEW	150 cm
Ornamental Grasses				
CaE	18	Celebregrisetia acutiflora 'El Dorado'	ELDORADO FEATHER REED GRASS	2 Gal
DnN	14	Deschampsia cespitosa 'Northern Lights'	NORTHERN LIGHTS HAIR GRASS	2 Gal
HmA	18	Hakonechloa macra 'All Gold'	ALL GOLD HAKONE GRASS	2 Gal
Perennials and Annuals				
ArJ	16	Ajuga reptans 'Jungle Beauty'	JUNGLE BEAUTY CARPET BUGLE	1 Gal
CgE	5	Coreopsis grandiflora 'Early Sunrise'	EARLY SUNRISE TICKSEED COREOPSIS	1 Gal
Ep	13	Echinacea pallida	PALE CONEFLOWER	1 Gal
Ep	17	Echinacea purpurea	PURPLE CONEFLOWER	1 Gal
GgG	18	Gaillardia x grandiflora 'Goblin'	GOBLIN BLANKET FLOWER	1 Gal
Go	9	Galium odoratum	SWEET WOODRUFF	1 Gal
MdB	29	Monarda didyma 'Blue Stocking'	BLUE STOCKING BEE BALM	1 Gal
Rh	41	Rudbeckia hirta	BLACK-EYED SUSAN	1 Gal
SM	32	Sedum 'Matrona'	MATRONA SEDUM	1 Gal
SaF	4	Sedum spurius 'Fuldaglut'	FULDAGLUT TWO ROW STONECROP	1 Gal

DECORATIVE DRIVEWAY PILLAR WITH ADDRESS NUMBER

STREET TREES BY DEVELOPER

INFILTRATION TRENCH BY DEVELOPER

#36 (LOT 24)

PROPOSED
1.5 STOREY
DWELLING

CREEDMORE COURT



36 (LOT 24) CREEDMORE CRT.

COMMITTEE OF ADJUSTMENT

SITE STATISTICS ZONING BYLAW SUMMARY

ZONING	RDI - EX. I3I6	
COVERAGE	N/A	
DENSITY	N/A	
HEIGHT	11.0M	
SETBACKS	FRONT	4.5M
	REAR	7.5M
	SIDE	1.2M
LOT AREA:	23743.76 SF 2205.80 M2	
PROP. GFA:		
GROUND FLOOR:	4,420 S.F.	410.70 M2
SECOND FLOOR:	1,439 S.F.	133.68 M2
TOTAL GFA:	5,859 S.F.	544.38 M2
FIN. BASEMENT AREA:	4,371 S.F.	406.12 M2
BLDG. COVERAGE:	5,658 S.F.	525.69 M2
* INCL. FRONT PORCH / EXCL. LOGGIA, FRONT PORCH STEPS, BASEMENT WALKOUT		
LOT COVERAGE:	23.83%	
PROP. HEIGHT:	12.74M	
PROP. BLDG. LENGTH:	AS SHOWN	
INDOOR PARKING:	4	

FRONT YARD	(A)	TOTAL FRONT YARD AREA	333.07 M2
	(B)	DRIVEWAY AREA + PAVED PATIO	68.30 M2
	(C)	TOTAL SOFT LANDSCAPED AREA	263.39 M2

REAR YARD	(A)	TOTAL REAR YARD AREA	838.61 M2
	(B)	REAR SOFT L'SCAPED AREA PROVIDED	502.97 M2
	MIN. SOFT LANDSCAPED AREA REQUIRED:		(838.61 M2- 135 M2) X 60%= 422.16 M2

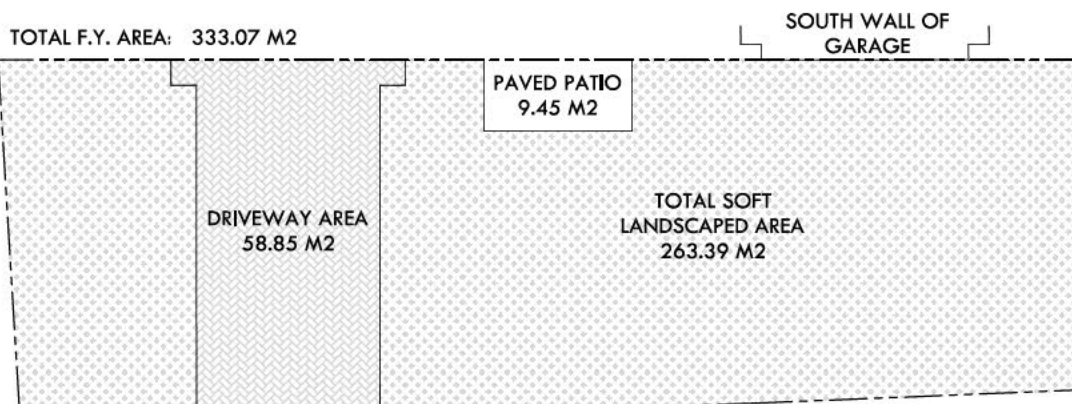

Zanjani Architect Inc.
15 Allstate Pkwy, Unit 664
Markham, ON L3R 5B4
T: 416.917.8285
E: info@zanjaniarchitect.com

07	FOR ARCH. CONTROL APPROVAL	OCT. 26, 2021	S.Z.
06	FOR C.O.A. RESUBMISSION	JUN. 08, 2021	S.Z.
05	FOR C.O.A. RESUBMISSION	DEC. 22, 2020	S.Z.
04	FOR C.O.A. SUBMISSION	NOV. 27, 2020	S.Z.
ITEMS 1-3 NOT SHOWN			
Issued:			

A0

PROPOSED 1.5-STOREY DWELLING 36 (LOT24) CREEDMORE CRT.
KLEINBURG, ON

STATS
SCALE: N/A

BLOCK 75
PIN 03322-0359
(PARK)

PARKLAND

LOT 24,

CONCESSIO

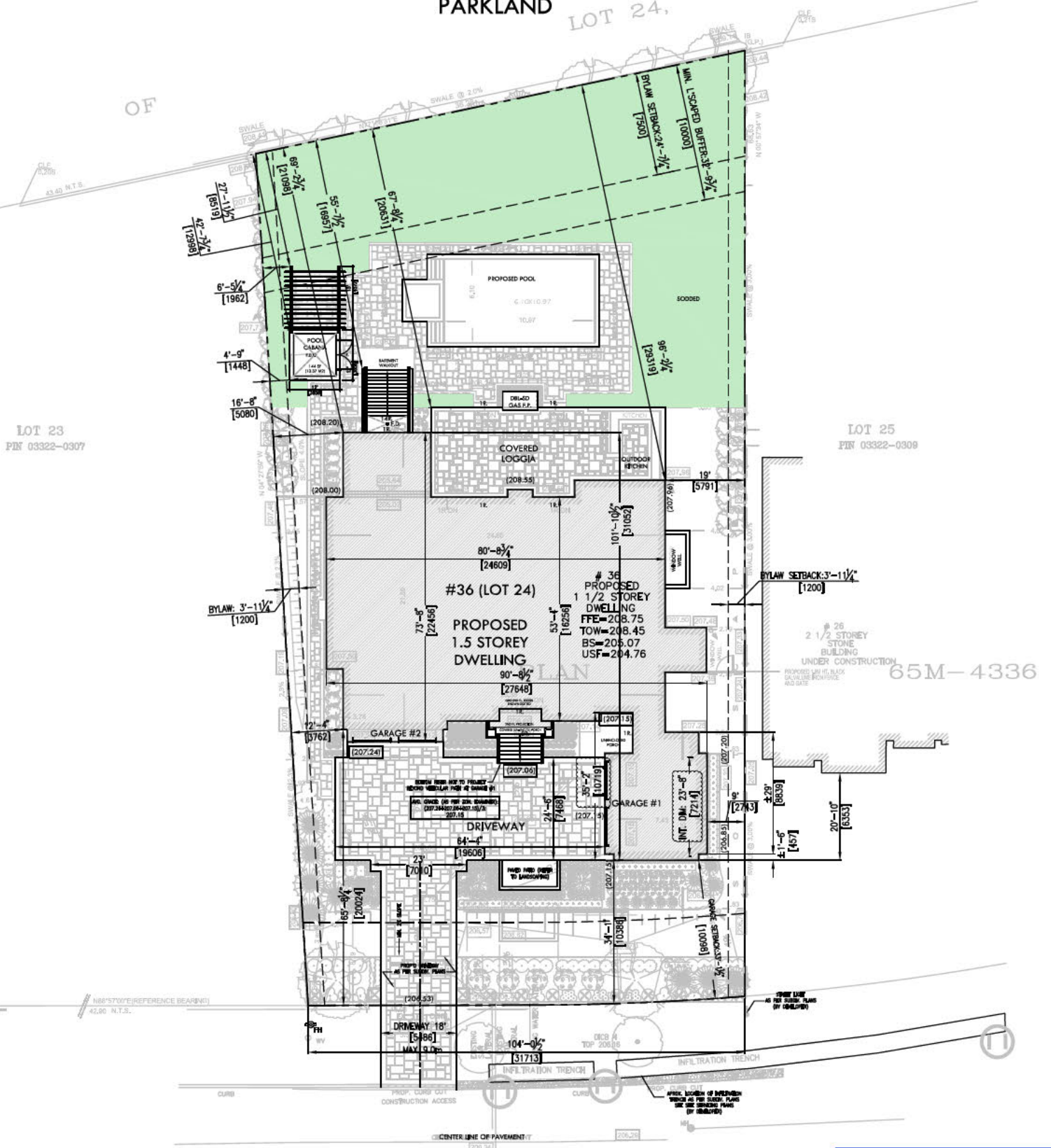

CREEDMORE COURT

W Architect Inc.
DESIGN CONTROL REVIEW
 OCT. 28, 2021
FINAL RECERT BY: *Alli*
 This stamp is only for the purposes of design control and carries no other professional obligations.

Zanjani Architect Inc.
 15 Allstate Pkwy, Unit 664
 Markham, ON L3R 5B4
 T: 416.917.8285
 E: info@zanjaniarchitect.com

07	FOR ARCH. CONTROL APPROVAL	OCT. 26, 2021	S.Z.
06	FOR C.O.A. RESUBMISSION	JUN. 08, 2021	S.Z.
05	FOR C.O.A. RESUBMISSION	DEC. 22, 2020	S.Z.
04	FOR C.O.A. SUBMISSION	NOV. 27, 2020	S.Z.
ITEMS 1-3 NOT SHOWN			
Issued:			

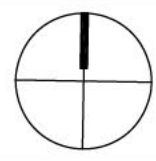

A1

PROPOSED 1.5-STOREY DWELLING 36 (LOT24) CREEDMORE CRT.
 KLEINBURG, ON

SITE PLAN
 SCALE: 1/32"=1'-0"

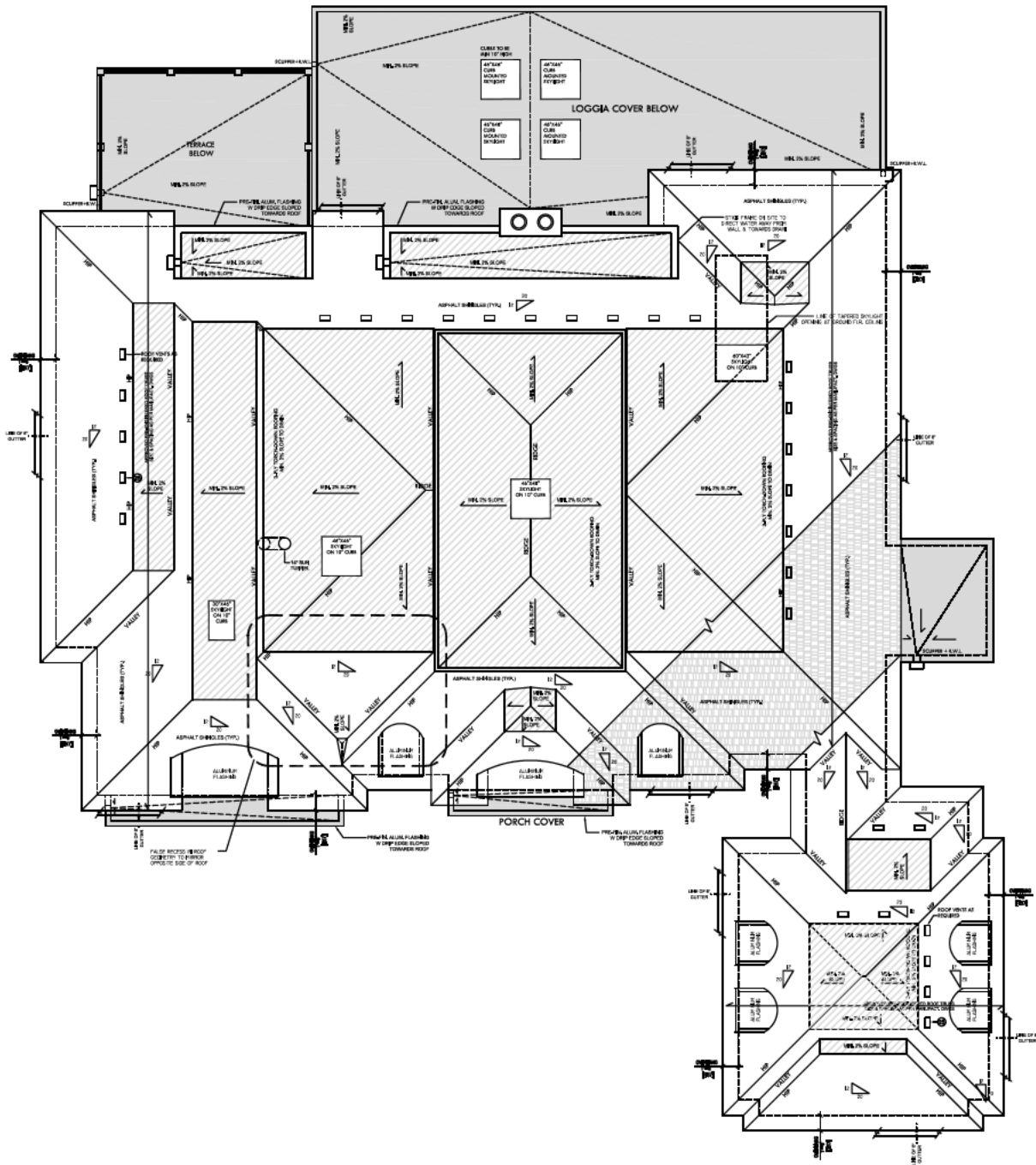

Zanjani Architect Inc.

15 Allstate Pkwy, Unit 664
 Markham, ON L3R 5B4
 T: 416.917.8285
 E: info@zanjaniarchitect.com

06	FOR ARCH. CONTROL APPROVAL	OCT. 26, 2021	S.Z.
05	FOR C.O.A. SUBMISSION	NOV. 27, 2020	S.Z.
	ITEMS 02-04 NOT SHOWN		
01	FOR C.O.A.	APR. 12, 2020	S.Z.
Issued:			

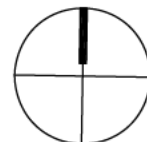

A5

PROPOSED 1.5-STOREY DWELLING

36 (LOT24) CREEDMORE CRT.
 KLEINBURG, ON

ROOF PLAN
 SCALE: 1/16"=1'-0"

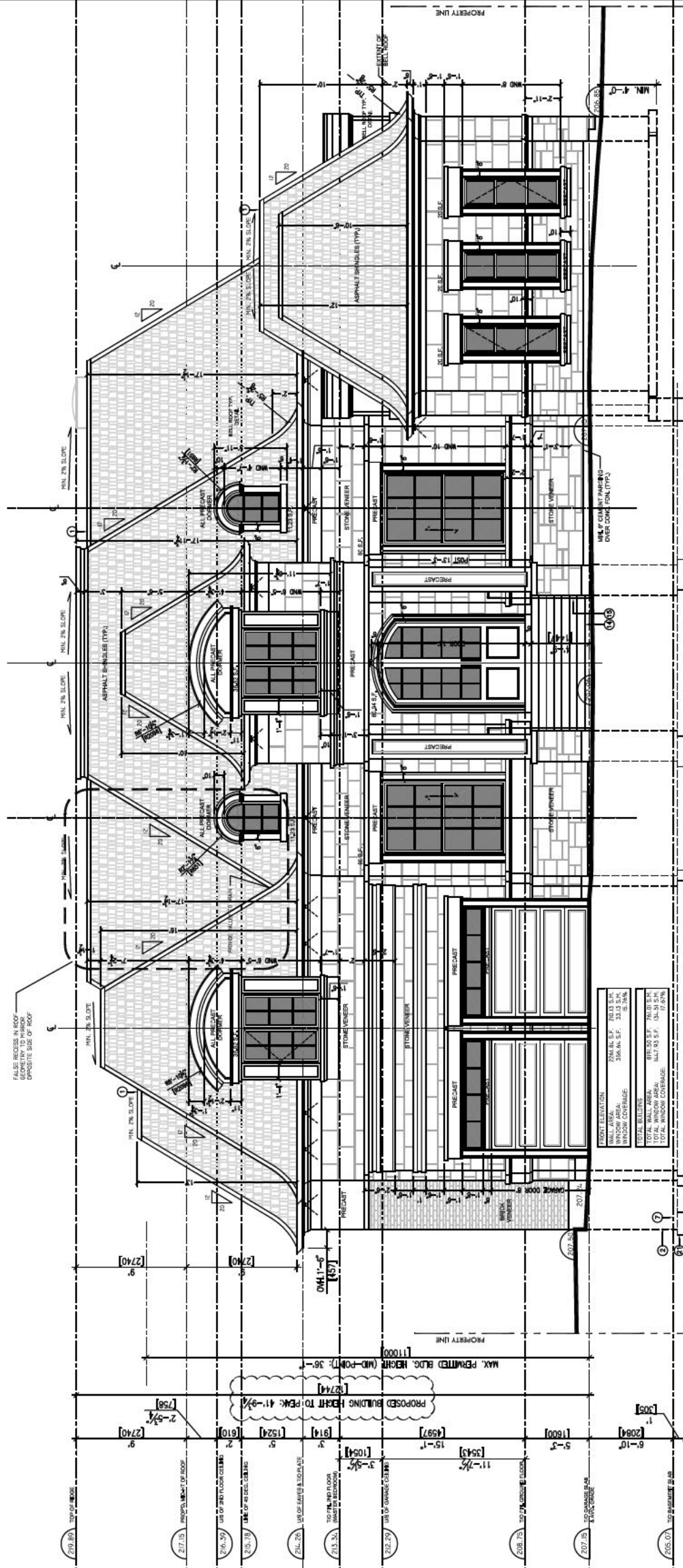

Zanjani Architect Inc.
 15 Allstate Pkwy, Unit 664
 Markham, ON L3R 5B4
 T: 416.917.8285
 E: info@zanjaniarchitect.com

06	FOR ARCH. CONTROL APPROVAL	OCT. 26, 2021	S.Z.
05	FOR C.O.A. SUBMISSION	NOV. 27, 2020	S.Z.
	ITEMS 02-04 NOT SHOWN		
01	FOR C.O.A.	APR. 12, 2020	S.Z.

A6

PROPOSED 1.5-STOREY DWELLING

36 (LOT24) CREEDMORE CRT.
 KLEINBURG, ON

FRONT (SOUTH) ELEVATION
 SCALE: 3/32"=1'-0"

W Architect Inc.
DESIGN CONTROL REVIEW
 OCT. 28, 2021
 FINAL
RECERT BY: *Al*
 This stamp is only for the purposes of design control and carries no other professional obligations.

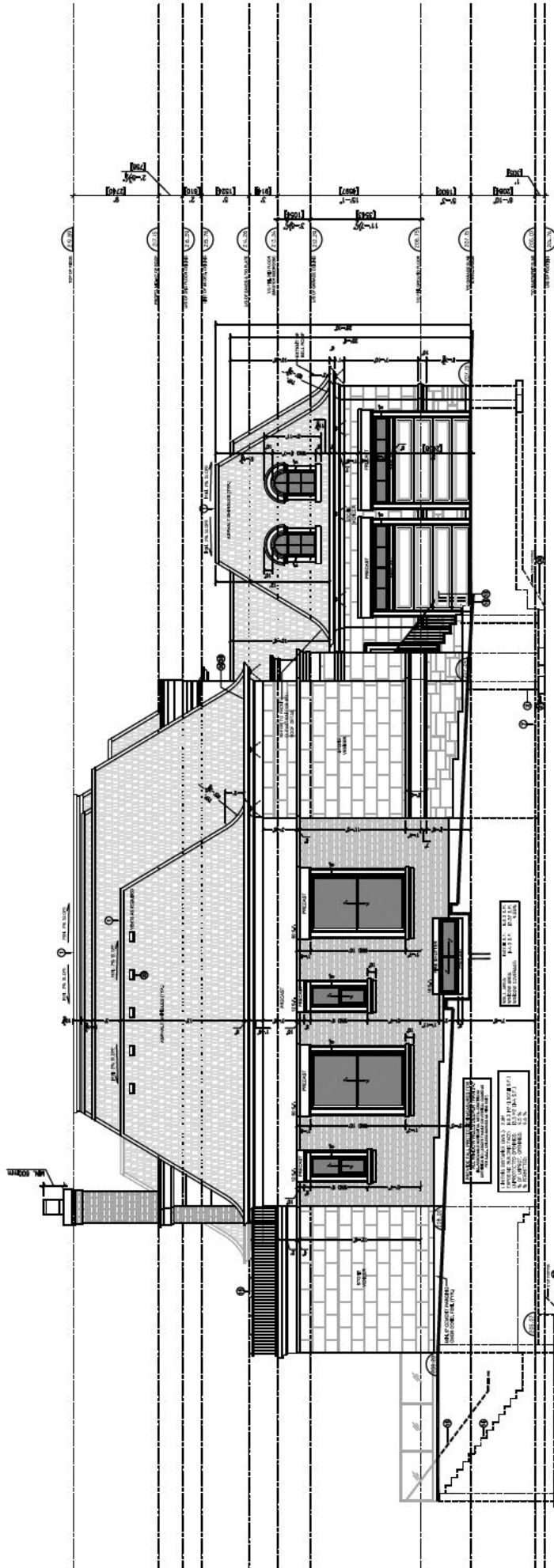

Zanjani Architect Inc.

15 Allstate Pkwy, Unit 664
 Markham, ON L3R 5B4
 T: 416.917.8285
 E: info@zanjaniarchitect.com

06	FOR ARCH. CONTROL APPROVAL	OCT. 26, 2021	S.Z.
05	FOR C.O.A. SUBMISSION	NOV. 27, 2020	S.Z.
	ITEMS 02-04 NOT SHOWN		
01	FOR C.O.A.	APR. 12, 2020	S.Z.
Issued:			

A7

PROPOSED 1.5-STOREY DWELLING

36 (LOT24) CREEDMORE CRT.
 KLEINBURG, ON

SIDE (WEST) ELEVATION
 SCALE: 1/16"=1'-0"

W Architect Inc.
DESIGN CONTROL REVIEW
 OCT. 28, 2021
FINAL RECERT BY: *ALL*
 This stamp is only for the purposes of design control and carries no other professional obligations.

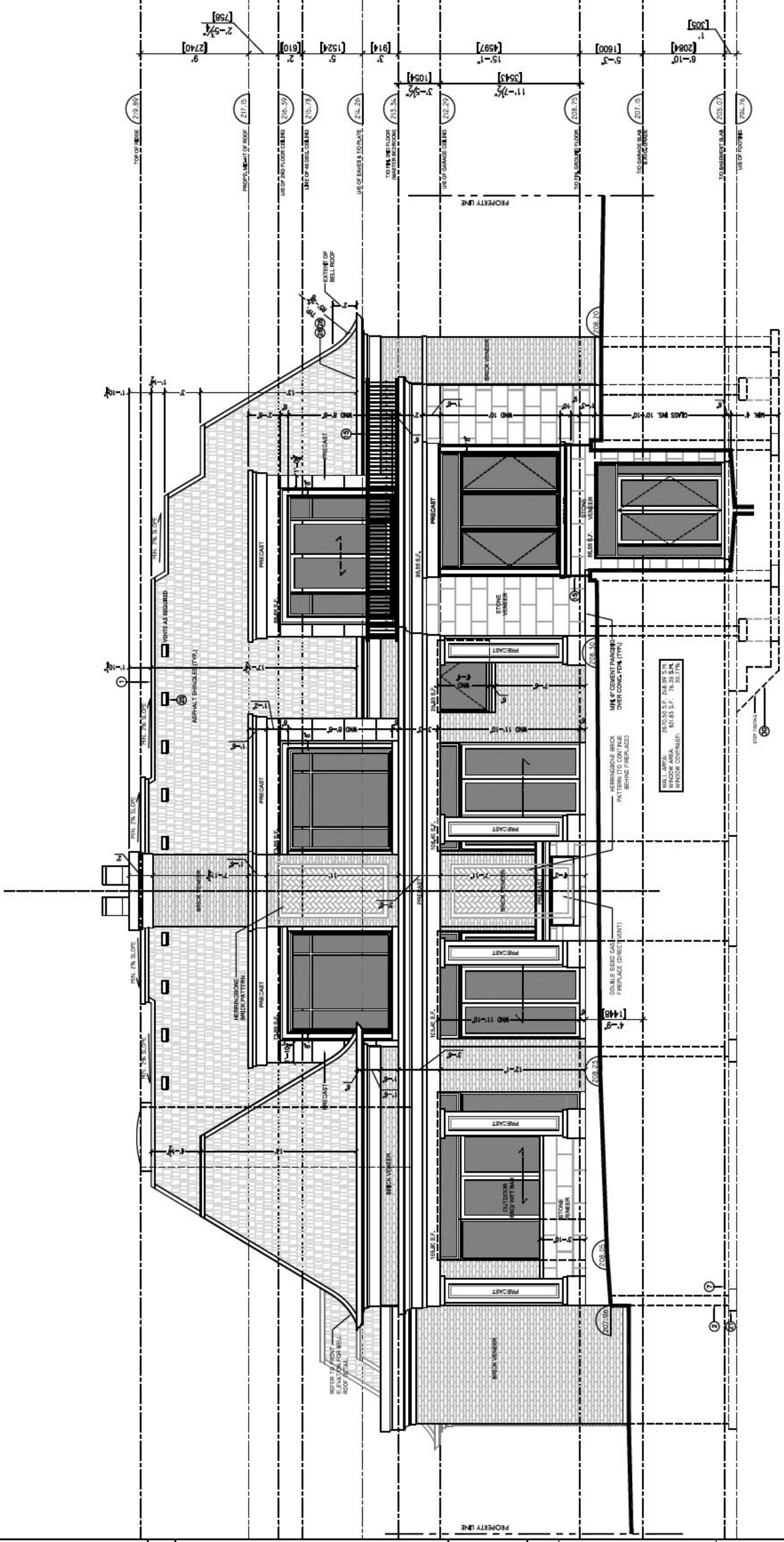

Zanjani Architect Inc.
 15 Allstate Pkwy, Unit 664
 Markham, ON L3R 5B4
 T: 416.917.8285
 E: info@zanjaniarchitect.com

06	FOR ARCH. CONTROL APPROVAL	OCT. 26, 2021	S.Z.
05	FOR C.O.A. SUBMISSION	NOV. 27, 2020	S.Z.
	ITEMS 02-04 NOT SHOWN		
01	FOR C.O.A.	APR. 12, 2020	S.Z.
Issued:			

A8

PROPOSED 1.5-STOREY DWELLING 36 (LOT24) CREEDMORE CRT. REAR (NORTH) ELEVATION
 KLEINBURG, ON SCALE: 3/32"=1'-0"

W Architect Inc.
DESIGN CONTROL REVIEW
 OCT. 28, 2021
FINAL RECERT BY: *ALL*
 This stamp is only for the purposes of design control and carries no other professional obligations.

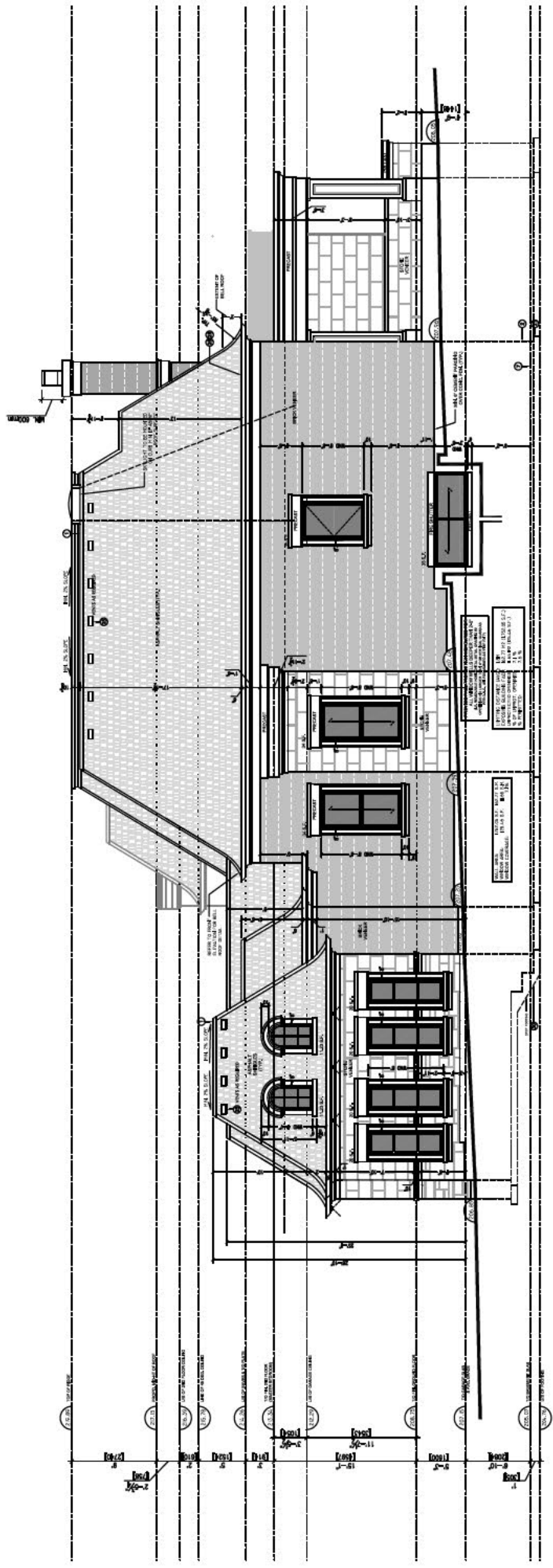

Zanjani Architect Inc.
 15 Allstate Pkwy, Unit 664
 Markham, ON L3R 5B4
 T: 416.917.8285
 E: info@zanjaniarchitect.com

06	FOR ARCH. CONTROL APPROVAL	OCT. 26, 2021	S.Z.
05	FOR C.O.A. SUBMISSION	NOV. 27, 2020	S.Z.
	ITEMS 02-04 NOT SHOWN		
01	FOR C.O.A.	APR. 12, 2020	S.Z.
Issued:			

A9

PROPOSED 1.5-STOREY DWELLING 36 (LOT24) CREEDMORE CRT.
 KLEINBURG, ON

SIDE (EAST) ELEVATION
 SCALE: 1/16"=1'-0"

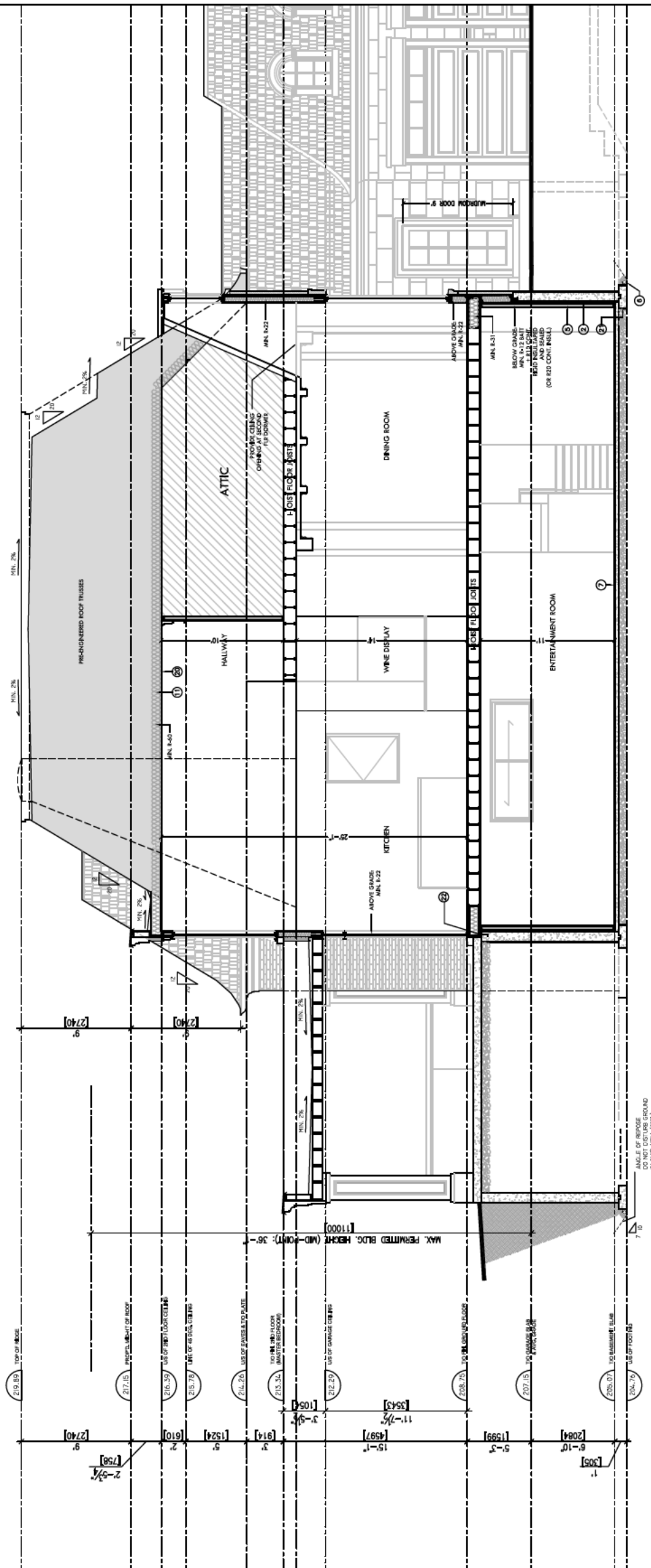

ANGLE OF REFUGE
DO NOT DISTURB GROUND
IN THIS AREA (11%)

Zanjani Architect Inc.
15 Allstate Pkwy, Unit 664
Markham, ON L3R 5B4
T: 416.917.8285
E: info@zanjaniarchitect.com

05	FOR ARCH. CONTROL APPROVAL	OCT. 26, 2021	S.Z.
04	FOR C.O.A. SUBMISSION	NOV. 27, 2020	S.Z.
03	FOR SIGNOFF GARAGE + BLDG. HT. REV.	NOV. 25, 2020	S.Z.
02	RE-ISSUED FOR C.O.A.	MAY. 02, 2020	S.Z.
01	FOR C.O.A.	APR. 12, 2020	S.Z.
Issued:			

A10

PROPOSED 1.5-STOREY DWELLING 36 (LOT24) CREEDMORE CRT.
KLEINBURG, ON

SECTION
SCALE: 3/32"=1'-0"

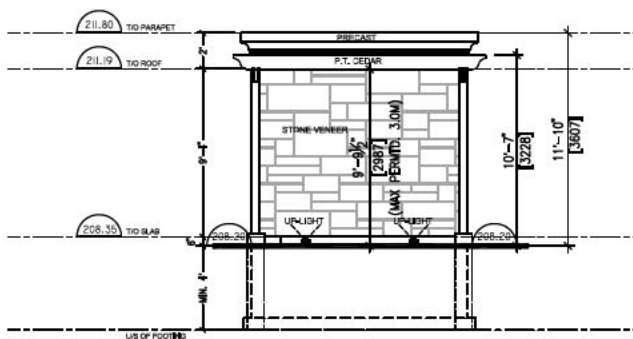
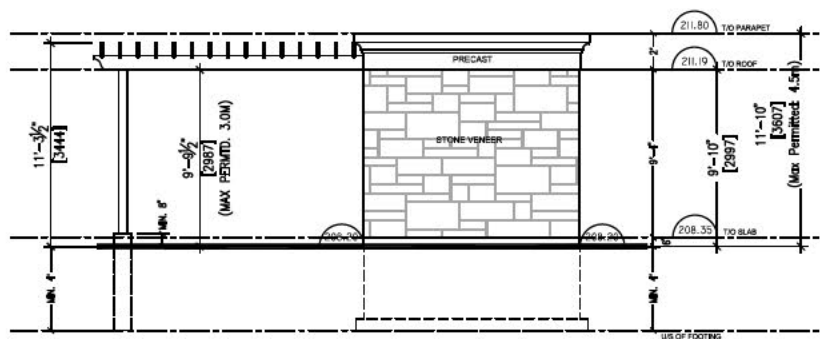
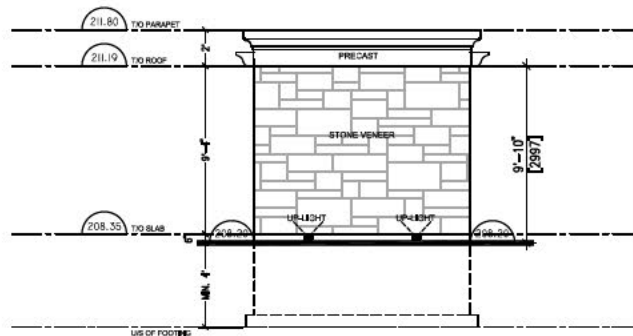
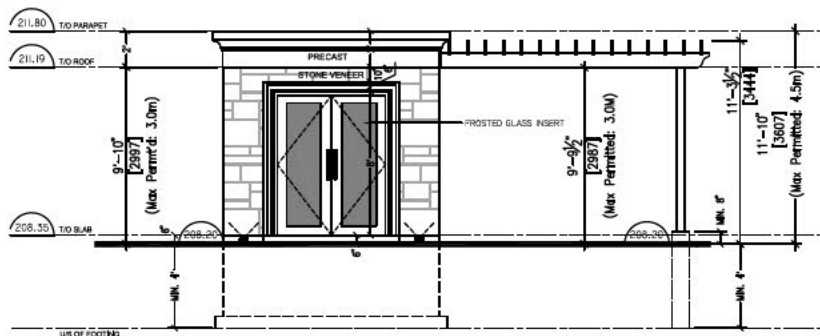
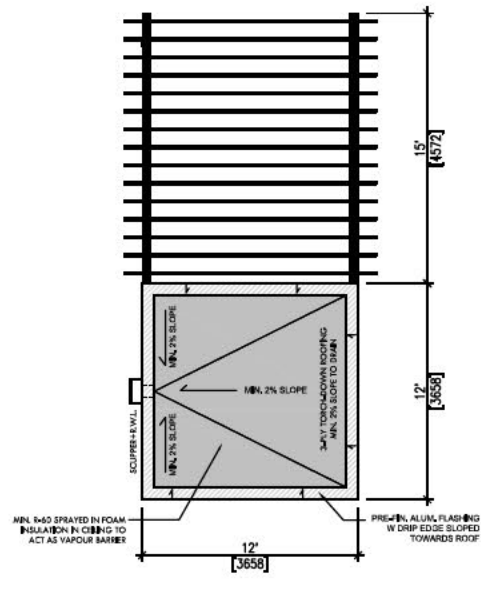
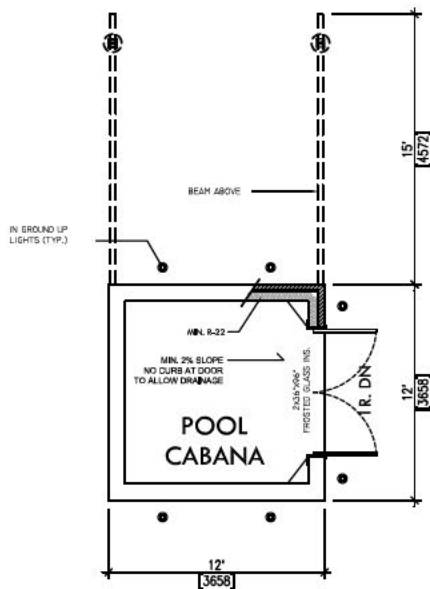
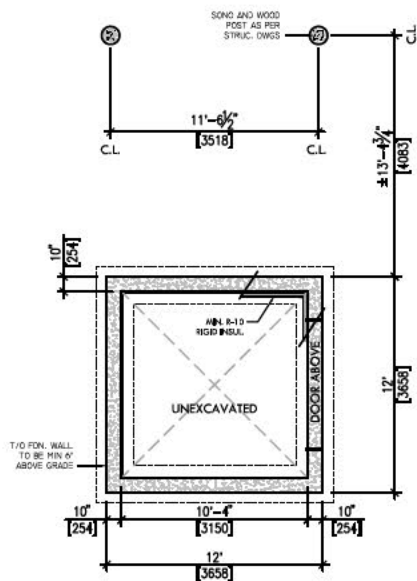

W Architect Inc.
DESIGN CONTROL REVIEW
 OCT. 28, 2021
FINAL RECERT BY: *Alc.*
 This stamp is only for the purposes of design control and carries no other professional obligations.

Zanjani Architect Inc.
 15 Allstate Pkwy, Unit 664
 Markham, ON L3R 5B4
 T: 416.917.8285
 E: info@zanjaniarchitect.com

06	FOR ARCH. CONTROL APPROVAL	OCT. 26, 2021	S.Z.
05	FOR C.O.A. SUBMISSION	NOV. 27, 2020	S.Z.
	ITEMS 02-04 NOT SHOWN		
01	FOR C.O.A.	APR. 12, 2020	S.Z.
Issued:			



A11

PROPOSED 1.5-STORY DWELLING

36 (LOT24) CREEDMORE CRT.
 KLEINBURG, ON

POOL CABANA
 SCALE: 3/32"=1'-0"



1. ASPHALT SHINGLES
Manufacturer: IKO
Colour: Dual Black

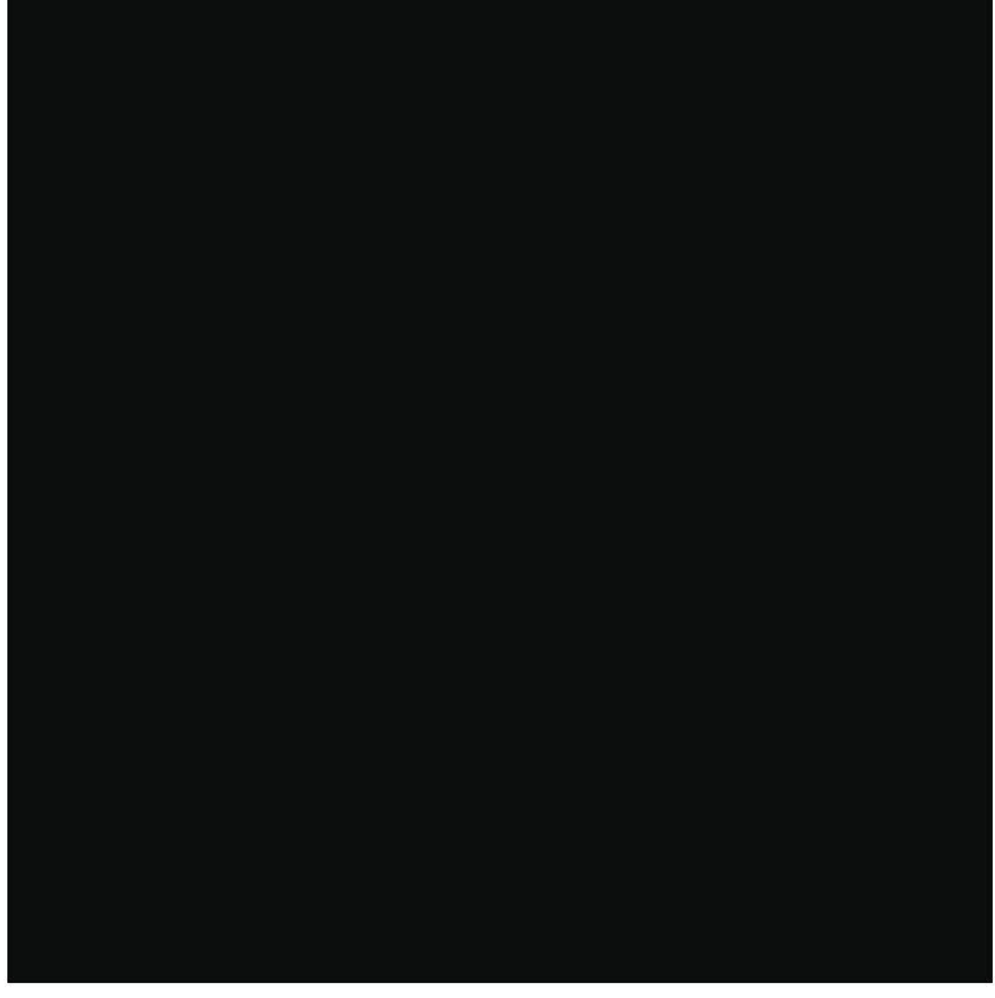

2. METAL FASCIA AND SOFFIT
Manufacturer: Vicwest
Colour: Black WXL 56068

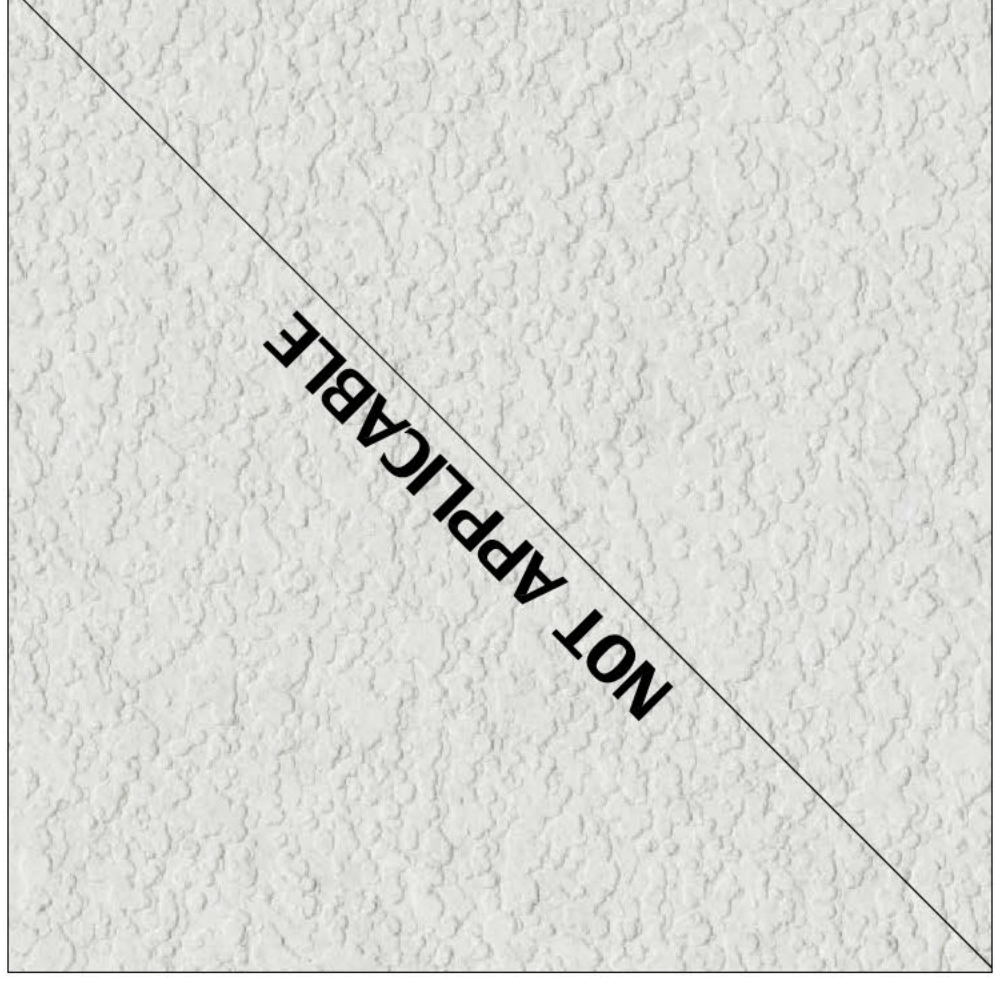

3. STUCCO (EIFS)
Manufacturer: Durock
Colour: Benjamin Moore OC-03

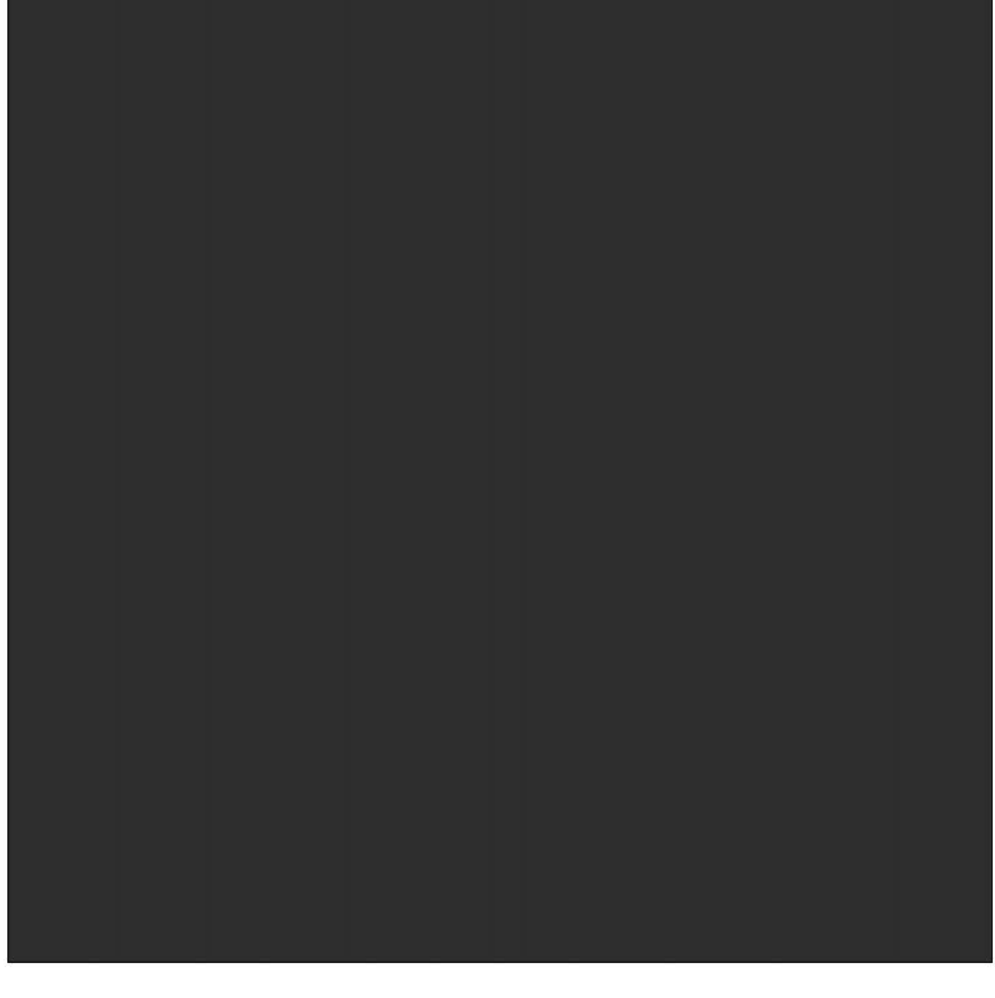

4. WINDOW FRAMES
Manufacturer: WINDOW CITY
Profile: Heritage Collection

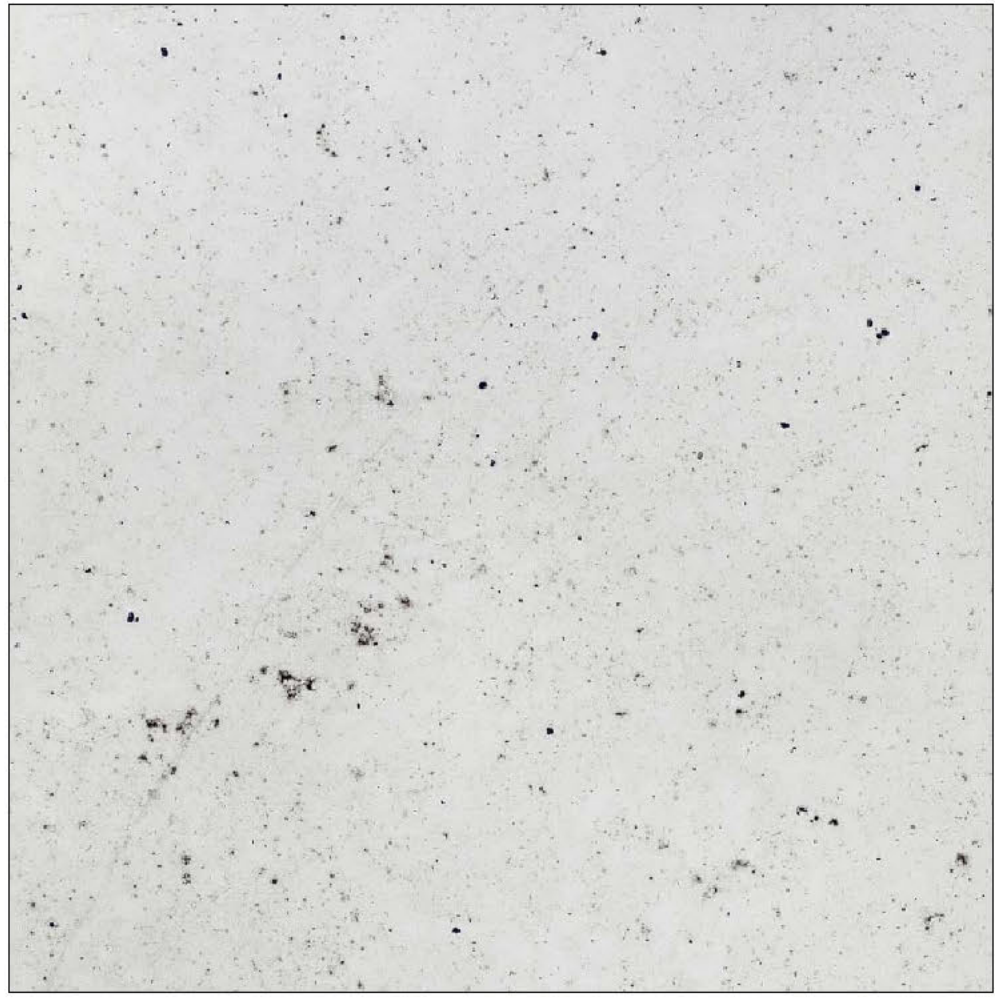

5. PRECAST CONCRETE
Manufacturer: Castle Precast
Colour: To Match Limestone

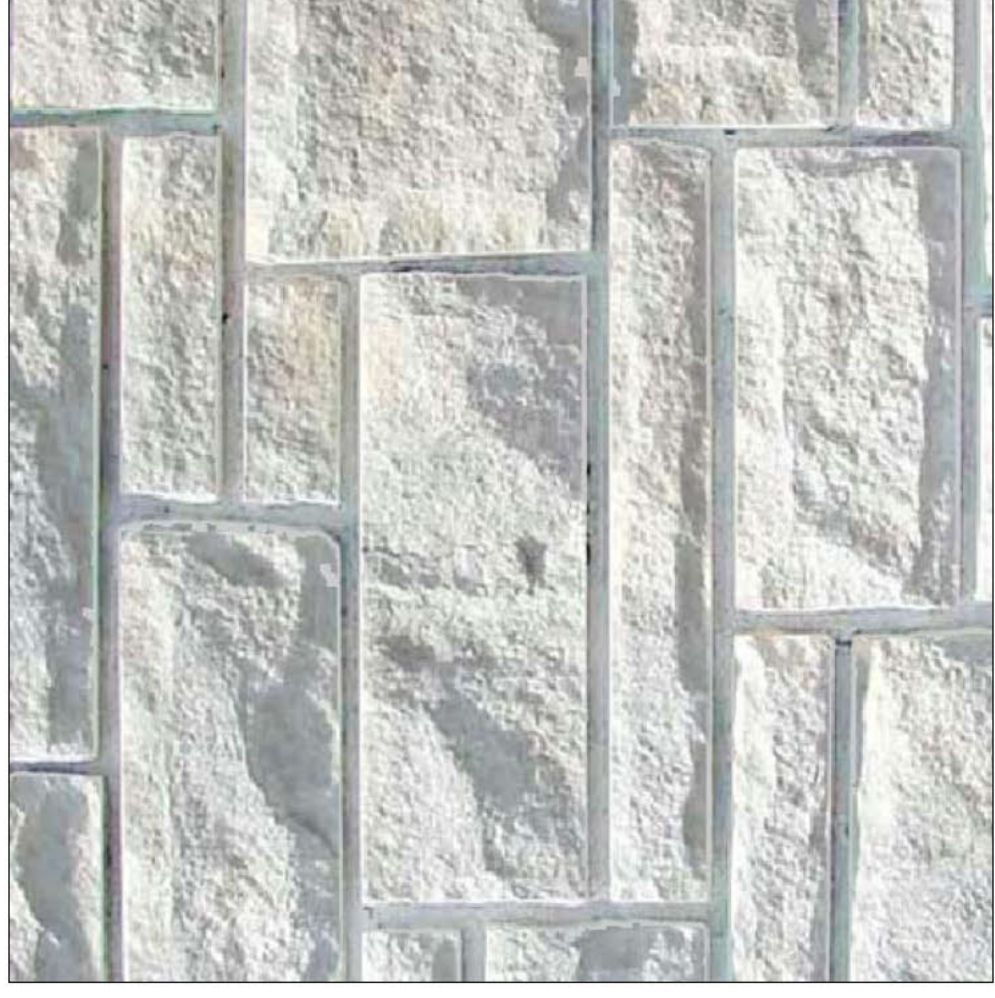

6. ROUGH STONE
Manufacturer: King Masonry
Colour: Rough Indiana Limestone

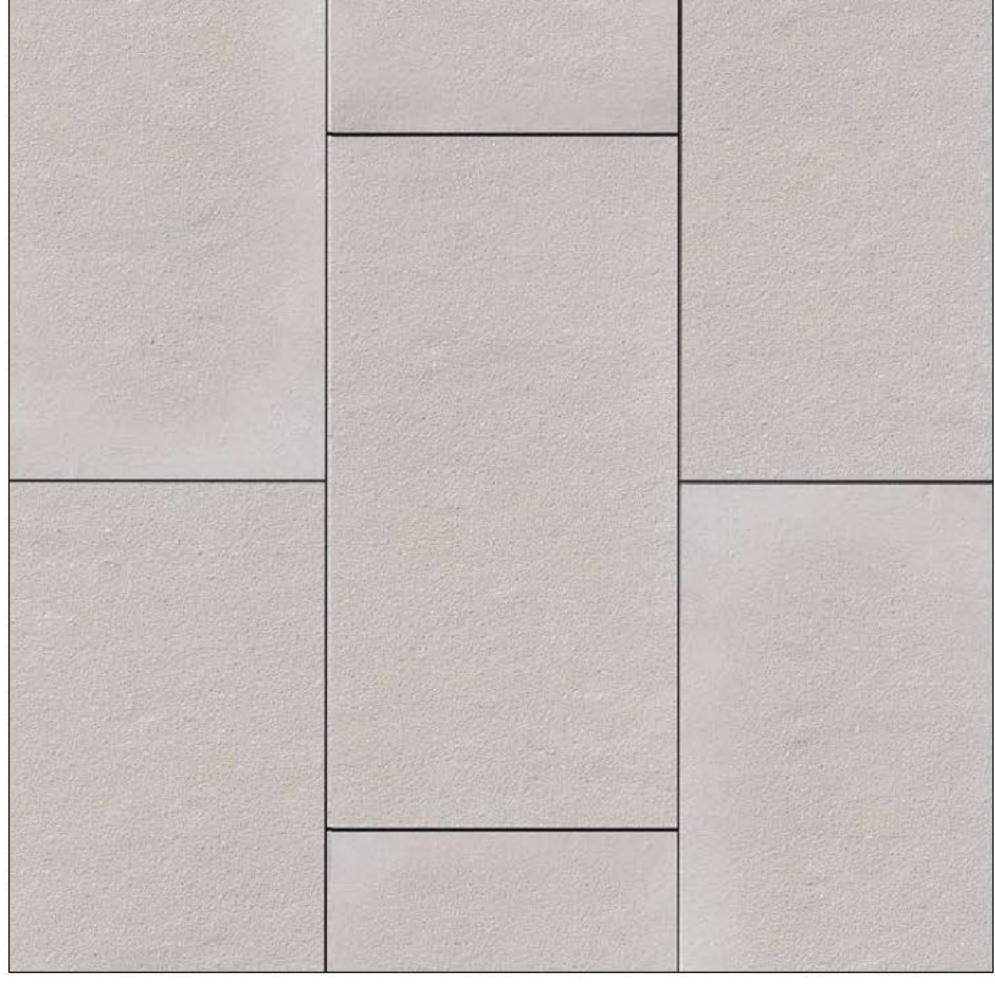

7. POLISHED STONE
Manufacturer: King Masonry
Colour: Smooth Indiana Limestone



8. BRICK VENEER
Manufacturer: Glen Gery
Colour: Silverbrook Thin Brick

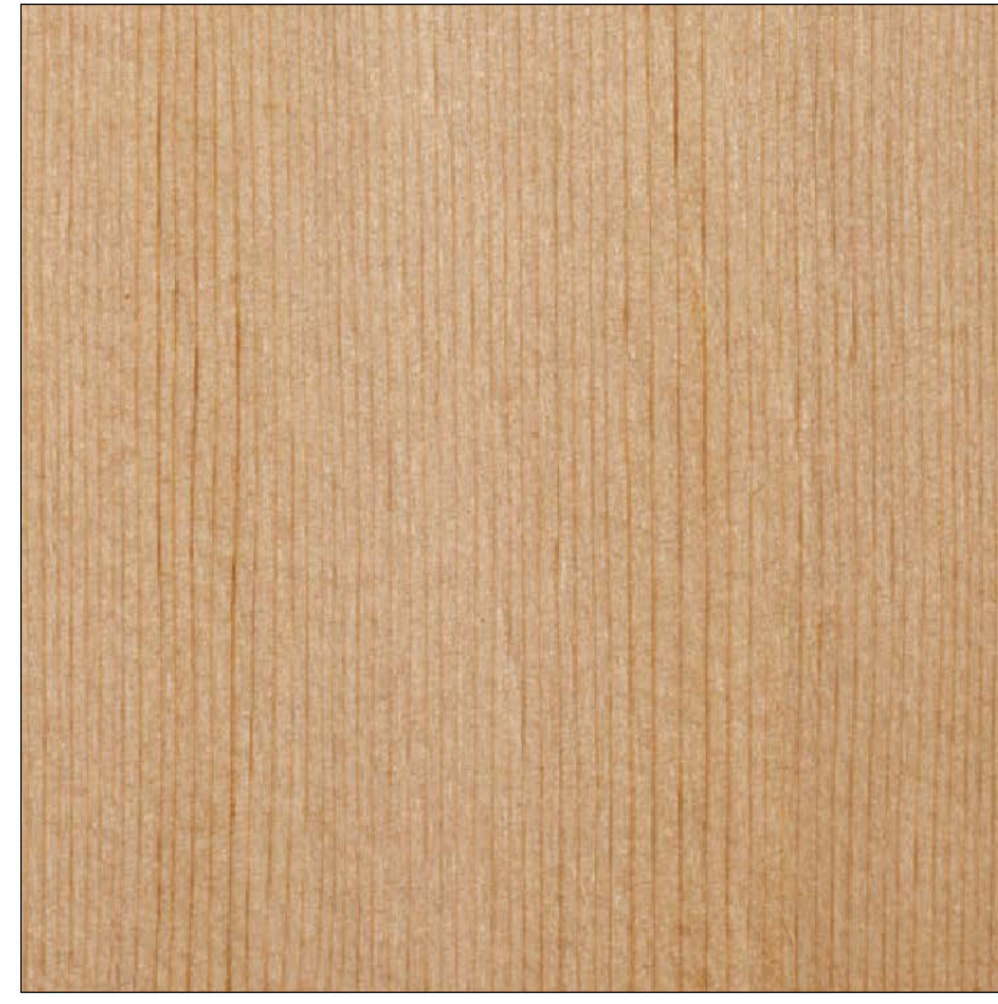

9. P.T. CEDAR
Manufacturer: T.B.D
Colour: Natural

The Architect does not retain the consultants and therefore is not responsible for the accuracy of survey, structural, mechanical, electrical, etc. engineering information shown on the drawing. Refer to the drawings and specifications for details and proceed with work.

Contractor shall verify and check all dimensions and conditions on site prior to starting any of the work. The contractor shall ensure that the Architect and consultants before proceeding. Construction must conform to all applicable Codes and Requirements of Authorities having jurisdiction pertaining to this application.

No investigation has been undertaken or reported on by this office in regards to the environmental condition or pollution of this site. This drawing is not to be scaled.

All dimensions and areas to be confirmed on site by Ontario Land Surveyor.

no.	date	issued	by
07	OCT. 28, 2021	FOR ARCH. CONTROL APPROVAL	SZ
06	JUL. 11, 2019	FOR ARCHITECTURAL CONTROL APPROVAL	SZ
05	DEC. 17, 2018	FOR ARCHITECTURAL CONTROL APPROVAL	SZ
04	OCT. 03, 2018	FOR ARCHITECTURAL CONTROL	SZ
03	APR. 27, 2018	FOR CLIENT REVIEW	SZ
02	MAR. 22, 2018	FOR ARCHITECTURAL CONTROL	SZ
01	FEB. 23, 2018	FOR CLIENT SIGN OFF	SZ

COPYRIGHT 2019 ZANJANI ARCHITECT INC.

PROJECT TITLE

**36 CREEDMORE CRT.
 SINGLE FAMILY
 RESIDENCE**

36 CREEDMOR CRT. LOT 24, KLEINBURG, ON

SHEET TITLE

**MATERIAL SAMPLE
 BOARD**

Zai. Zanjani Architect Inc. 1200 Sheppard Ave. E. #1000, Scarborough, ON M1S 1T5	DATE	JUL. 2017
	DATE PLOTTED	JUL 11, 2019
PROJECT NO.	17115	
DRAWN BY	SZ	SZ
CHECKED BY	SZ	SZ
DRAWING NO.	MATERIALS	
SCALE	N.T.S.	



Schedule B: Public Correspondence Received

Please note that the correspondence listed in Schedule B is not comprehensive. Written submissions received after the preparation of this staff report will be provided as an addendum.

None

Schedule C: Agency Comments

Please note that the correspondence listed in Schedule C is not comprehensive. Comments received after the preparation of this staff report will be provided as an addendum.-

Development Planning Comments

Alectra (Formerly PowerStream) – No concerns or objections

Region of York – No concerns or objections

CPR – comments with guidelines

To: Christine Vigneault, Committee of Adjustment Secretary Treasurer
From: Nancy Tuckett, Director of Development Planning
Date: November 18, 2021
Name of Owner: 2572486 Ontario Ltd.
Location: 36 Creedmore Court
File No.(s): A203/21

Proposed Variance(s):

1. To permit a maximum garage projection of 10.72 m.
2. To permit a maximum height of 12.74 m for a dwelling.
3. To permit a garage with minimum interior garage dimensions of 7.01 m width x 5.79 m length.

By-Law Requirement(s):

1. No garage shall project into the front yard or exterior yard more than 1 m beyond the most distant point of any wall of the dwelling facing the street at the ground floor level and a maximum of 2 m where there is a covered and unenclosed porch. [General Notes, Schedule A3]
2. A maximum building height of 11 m is permitted. [Schedule A3]
3. Minimum interior garage dimensions of 5.5 m width x 6.0 m length are required. [General Notes, Schedule A3]

Official Plan:

City of Vaughan Official Plan 2010 ('VOP 2010'): "Low-Rise Residential"

Comments:

The Owner is proposing to construct a two-storey single detached dwelling with the above-noted variances.

The Development Planning Department has no objection to the requested variances. The scale and massing of the proposed dwelling is in keeping with the built form of the existing estate lot character of the neighbourhood, with the proposed building height consistent with previous approvals in the neighbourhood. The proposed maximum garage projection of 10.72 m for Garage 1 is considered appropriate, as the garage door faces internally and has limited visibility from the street, while the front wall of the garage contains a similar façade treatment as the main front wall of the dwelling. The Development Planning Department has no concerns with Variance 3 and is of the opinion that the proposed garage dimension maintains the intent of the Zoning By-law, as Garage 2 can still facilitate the parking of two vehicles.

Urban Design staff have reviewed the application and have recommended that the Owner provide a letter from the Control Architect of the subdivision confirming there are no concerns with the proposed development. A condition to this effect has been included in the Conditions of Approval.

Accordingly, the Development Planning Department is of the opinion that the proposal is minor in nature, maintains the general intent and purpose of the Official Plan and Zoning By-law, and is desirable for the appropriate development of the land.

Recommendation:

The Development Planning Department recommends approval of the application, subject to the following condition:

Conditions of Approval:

If the Committee finds merit in the application, the following condition(s) of approval are recommended:

1. The Owner shall provide a letter from the Control Architect that confirms there are no concerns with the proposed development.

Comments Prepared by:

Michael Torres, Planner I

Chris Cosentino, Senior Planner

Date: October 6th , 2021

Attention: **Christine Vigneault**

RE: Request for Comments

File No.: **A203-21**

Related Files:

Applicant 2572486 Ontario Ltd. (Dang Trinh)

Location 36 Creedmore Court



Discover the possibilities

COMMENTS:

- We have reviewed the proposed Variance Application and have no comments or objections to its approval.
- We have reviewed the proposed Variance Application and have no objections to its approval, subject to the following comments (attached below).
- We have reviewed the proposed Variance Application and have the following concerns (attached below).

Alectra Utilities (formerly PowerStream) has received and reviewed the proposed Variance Application. This review, however, does not imply any approval of the project or plan.

All proposed billboards, signs, and other structures associated with the project or plan must maintain minimum clearances to the existing overhead or underground electrical distribution system as specified by the applicable standards, codes and acts referenced.

In the event that construction commences, and the clearance between any component of the work/structure and the adjacent existing overhead and underground electrical distribution system violates the Occupational Health and Safety Act, the customer will be responsible for 100% of the costs associated with Alectra making the work area safe. All construction work will be required to stop until the safe limits of approach can be established.

In the event construction is completed, and the clearance between the constructed structure and the adjacent existing overhead and underground electrical distribution system violates the any of applicable standards, acts or codes referenced, the customer will be responsible for 100% of Alectra's cost for any relocation work.

References:

- Ontario Electrical Safety Code, latest edition (Clearance of Conductors from Buildings)
- Ontario Health and Safety Act, latest edition (Construction Protection)
- Ontario Building Code, latest edition (Clearance to Buildings)
- PowerStream (Construction Standard 03-1, 03-4), attached
- Canadian Standards Association, latest edition (Basic Clearances)

If more information is required, please contact either of the following:

Mr. Stephen Cranley, C.E.T
Supervisor, Distribution Design, ICI & Layouts (North)
Phone: 1-877-963-6900 ext. 31297

Mr. Tony D'Onofrio
Supervisor, Subdivisions (Alectra East)
Phone: 1-877-963-6900 ext. 24419

E-mail: stephen.cranley@alectrautilities.com

Email: tony.donofrio@alectrautilities.com

Pravina Attwala

Subject: FW: A203/21 (36 CREEDMORE COURT) - REQUEST FOR COMMENTS

From: CP Proximity-Ontario <CP_Proximity-Ontario@cpr.ca>

Sent: October-06-21 10:28 AM

To: Committee of Adjustment <CofA@vaughan.ca>

Subject: [External] RE: A203/21 (36 CREEDMORE COURT) - REQUEST FOR COMMENTS

Good Morning,

RE: A203/21 (36 CREEDMORE COURT) - REQUEST FOR COMMENTS, Subdivision within 500m of CP Rail line

Thank you for the recent notice respecting the captioned development proposal in the vicinity of Canadian Pacific Railway Company. The safety and welfare of residents can be adversely affected by rail operations and CP is not in favour of residential uses that are not compatible with rail operations. CP freight trains operate 24/7 and schedules/volumes are subject to change. CP's approach to development in the vicinity of rail operations is encapsulated by the recommended guidelines developed through collaboration between the Railway Association of Canada and the Federation of Canadian Municipalities. The 2013 Proximity Guidelines can be found at the following website address: <http://www.proximityissues.ca/>.

Should the captioned development proposal receive approval, CP respectfully requests that the recommended guidelines be followed.

Thank you,

CP Proximity Ontario



CP Proximity Ontario
CP_Proximity-Ontario@cpr.ca
7550 Ogden Dale Road SE, Building 1
Calgary AB T2C 4X9

Pravina Attwala

Subject: FW: A203/21 (36 CREEDMORE COURT) - REQUEST FOR COMMENTS

From: Hurst, Gabrielle <Gabrielle.Hurst@york.ca>

Sent: October-13-21 8:45 AM

To: Pravina Attwala <Pravina.Attwala@vaughan.ca>

Cc: Committee of Adjustment <CofA@vaughan.ca>

Subject: [External] RE: A203/21 (36 CREEDMORE COURT) - REQUEST FOR COMMENTS

Good afternoon Pravina,

The Regional Municipality of York has completed its review of the above minor variance and has no comment.

Gabrielle

Gabrielle Hurst mcip rpp | Community Planning and Development Services | The Regional Municipality of York | 1-877
464 9675 ext 71538 | gabrielle.hurst@york.ca | www.york.ca