

THIS **WATER AND WASTEWATER ASSET OWNERSHIP AGREEMENT** dated _____, 2020

BETWEEN

THE REGIONAL MUNICIPALITY OF YORK

(the “**Region**”)

- and -

THE CORPORATION OF THE CITY OF VAUGHAN

(the “**City**”)

RECITALS:

- A. Section 11 of the *Municipal Act, 2001* provides that the Region has exclusive jurisdiction over water production, treatment, and storage.
- B. Section 11 of the *Municipal Act, 2001* further provides that the Region and the City each have non-exclusive jurisdiction over water distribution, collection of sanitary sewage, and sewage treatment.
- C. The Region and the City wish to:
 - (i) delineate the ownership boundary of Regional Water and Wastewater Infrastructure between the Region and the City;
 - (ii) establish requirements for the transfer of asset ownership; and
 - (iii) establish access rights over water and wastewater infrastructure and the lands in which the infrastructure resides.

The parties agree:

1. DEFINITIONS

1.1 For the purposes of this Agreement, the following definitions apply:

- (a) “**Assets**” means water and wastewater infrastructure, including watermains, forcemains, gravity sewers, facilities, wells, valves, maintenance holes, chambers, and siphons;

- (b) **“Business Day”** means any day except Saturdays, Sundays and Holidays in the Province of Ontario;
- (c) **“City”** means the Corporation of the City of Vaughan as a municipal corporation and, where the context requires, its geographic area;
- (d) **“City Assets”** means all the Assets under the jurisdiction or ownership of the City;
- (e) **“City Lands”** means the lands in, over, under, and across, which the City’s Assets are located and where the City has a property right, and includes a highway, street, road allowance, lane, or bridge, under the jurisdiction of the City;
- (f) **“City Property”** means collectively the City Lands and the City Assets;
- (g) **“Digital Stamp”** means an acceptance stamp that has been applied digitally to water and wastewater infrastructure drawings to indicate the Regional ownership delineation point as set out in the attached Schedule A that has been reviewed and approved by the Region and the City;
- (h) **“Effective Date”** means the date stated in the introductory clause;
- (i) **“Holidays”** means each and all of (a) New Year’s Day, (b) Family Day (c) Good Friday, (d) Victoria Day, (e) Canada Day, (f) Labour Day, (g) Thanksgiving Day, (h) Christmas Day, (i) Easter Sunday, and (j) any other public holiday declared by proclamation of the Lieutenant Governor of the Province of Ontario to be a holiday;
- (j) **“Region”** means The Regional Municipality of York as a municipal corporation and, where the context requires, its geographic area;
- (k) **“Regional Assets”** means all the Assets under the jurisdiction or ownership of the Region;
- (l) **“Regional Lands”** means the lands in, over, under, and across, which the Regional Assets are located and where the Region has a property right, and includes a highway, street, road allowance, lane, or bridge, under the jurisdiction of the Region;
- (m) **“Regional Ownership Boundary”** means the Regional ownership delineation point where Regional jurisdiction begins as set out in the attached Schedule A;
- (n) **“Regional Property”** means collectively, the Regional Lands and the Regional Assets; and

- (o) “Term” has the meaning set out in Section 11.1.

2. LEGISLATIVE COMPLIANCE

- 2.1 The Region and the City shall each be responsible for complying with all applicable legislation, regulations, policies, and guidelines, regarding Assets under their respective jurisdiction and ownership, including:
 - (a) the *Safe Drinking Water Act, 2002*;
 - (b) the *Ontario Water Resources Act, RSO 1990, c O40*;
 - (c) the *Clean Water Act, 2006*;
 - (d) the *Environmental Protection Act, RSO 1990, c E19*;
 - (e) the *Environmental Assessment Act, RSO 1990, c E18*; and
 - (f) the *Water Opportunities Act, 2010*.

3. CITY RESPONSIBILITY

- 3.1 The parties acknowledge that the City has title to or jurisdiction over the City Assets.
- 3.2 This Agreement does not change the jurisdiction or ownership of any City Property.
- 3.3 The City shall maintain and update its water and wastewater GIS layers annually at a minimum in order to correctly reflect the City Assets and the Regional Ownership Boundary.
- 3.4 Completed GIS updates shall be made available by the City through GIS information sharing to the Region through the YorkMaps “Water and Wastewater” viewer and externally through the “All Pipes” viewer, or other means as agreed upon by the parties. If any of the aforementioned applications are not functioning or are not available, other methods may be used by the parties.
- 3.5 All data exchange shall be in accordance with the YorkInfo Commons Data Exchange Agreement between the Region and the City dated January 1, 2014 (the “**YorkInfo Agreement**”).

4. REGIONAL RESPONSIBILITY

- 4.1 The parties acknowledge that the Region has title to or jurisdiction over Regional Assets as defined by the Region’s Water and Wastewater Infrastructure, Regional Jurisdiction Policy attached as Schedule B as amended from time to time.
- 4.2 This Agreement does not change the jurisdiction or ownership of any Regional Property.

- 4.3 The Region shall maintain and update its water and wastewater GIS layers semiannually at a minimum in order to correctly reflect the Region Assets and the Regional ownership delineation point as defined in the attached Schedule A.
- 4.4 Completed GIS updates shall be made available by the Region through GIS information sharing to the City through the YorkMaps “Water and Wastewater” viewer and externally through the “All Pipes” viewer, or other means as agreed upon by the parties. If any of the aforementioned applications are not functioning or are not available, other methods may be used by the parties.
- 4.5 All data exchange shall be in accordance with the YorkInfo Agreement.

5. REGIONAL ASSET OWNERSHIP DELINEATION

- 5.1 The Regional ownership delineation in this Agreement shall bind the Region and the City.
- 5.2 Ownership delineation of Regional Assets shall be completed by a digital mark-up process in which the date, a secured digital stamp and authorized signatures by both parties will be applied digitally to water and wastewater infrastructure drawings to indicate the Regional Ownership Boundary has been reviewed and approved by the Region and the City.
- 5.3 Further to Section 5.2, the Region’s Water or Wastewater Operations Manager or designate will apply their signature to indicate the Regional Ownership Boundary has been reviewed and approved by the Region.
- 5.4 Further to Section 5.2, the City’s Water or Wastewater Operations Manager or designate will apply their signature to indicate the Regional Ownership Boundary has been reviewed and approved by the City.
- 5.5 The Region and the City shall attend quarterly or semiannually water and wastewater operation partnership meetings to review and discuss:
 - (a) operational issues concerning the Regional Assets and City Assets;
 - (b) ownership delineation of Regional Assets;
 - (c) Assets that are candidates for jurisdictional transfer;
 - (d) Requirements for the completion of a transfer in progress: and
 - (e) the decommissioning of existing Regional Assets or City Assets.
- 5.6 Once the fully executed digital mark-up referenced in Section 5.2 is signed in accordance with Sections 5.3 and 5.4, the final original will be exchanged by the parties at the next

soonest quarterly and semiannual water and wastewater operation partnership meetings referenced in Section 5.5.

- 5.7 If there is a disagreement between the parties or discrepancy between the GIS information referenced in Section 4.4 and the digital mark-up referenced in this Section 5 as it relates to the ownership delineation, the parties agree that the ownership delineation shown in the most current dated, digitally stamped and fully signed digital mark-up shall prevail.

6. TRANSFER OF ASSET OWNERSHIP PROTOCOL

- 6.1 The Region and the City must mutually agree before the transfer of ownership of any Assets occurs between the parties.
- 6.2 Transfer of ownership can be either from the City to the Region or from the Region to the City.
- 6.3 The Jurisdictional Criteria detailed in the Region's Water and Wastewater Infrastructure, Jurisdiction Policy (Schedule B) shall be considered when assessing the proposed transfer of jurisdiction or ownership of any Assets.
- 6.4 All available records in relation to the construction, inspection, maintenance, and repair of each asset being considered for transfer shall be made available to the transferee.
- 6.5 The parties shall complete an analysis, as applicable, to assess the long-term operating, maintenance, and capital costs of the Assets, and to assess whether development charges and asset replacement reserves shall be transferred, as applicable.
- 6.6 A condition assessment shall be completed for any Assets being considered for transfer and shall be completed and paid for by the transferor or as mutually agreed.
- 6.7 The Region and the City must mutually agree on the conditions of transfer, including the amount of consideration to be paid, if any, and complete the transfer within 18 months after completion of the condition assessment or alternatively terminate the process.
- 6.8 The Region and the City shall each prepare a report to their respective Councils or Council delegate as applicable concerning the proposed transfer of asset ownership.

7. ACCESS RIGHTS

- 7.1 The City consents to the Region entering the City Property as necessary for the Region to fulfill its obligations or exercise its rights under this Agreement provided that the Region:

- (a) obtains and complies with all City and other permits and authorizations required to perform the proposed work, including where applicable a road occupancy permit;
- (b) except in the case of emergency, notifies the City a minimum of forty-eight (48) hours before the Region's entry;
- (c) shall not enter on or access the City Property for any purpose other than fulfilling its obligations or exercising its rights under this Agreement; and
- (d) shall at its sole expense restore the City Property to the same or better condition as existed immediately prior to the Region's entry.

7.2 The Region shall make all payments and take all steps necessary to ensure that no lien or notice of claim under the *Construction Act*, RSO 1990, c C30 (the "**Construction Act**") is registered against the City Lands or is received by the City, as a result of any works, services, or materials supplied under this Agreement to or for the Region. The Region shall cause any registration or notice to be discharged or vacated within thirty (30) days after receipt. If the Region fails to cause any such lien to be discharged or vacated, then in addition to any other rights and remedies that the City may have, the City may discharge or vacate the lien by paying into court the amount claimed as well as any prescribed security, and upon demand the Region shall reimburse the City for all amounts paid including the City's legal fees and disbursements.

7.3 The Region is solely responsible for all risks resulting from the Region entering the City Property. The City shall have no liability for the personal injury or death of any person, or damage to any property, that arises out of, or is in any way connected to, the exercise by the Region of its access rights under Section 7.1, except to the extent that the personal injury or death of any person or damage to any property was caused by the negligence or willful misconduct of the City.

7.4 The Region consents to the City entering the Regional Property as necessary for the City to fulfil its obligations under this Agreement provided that the City:

- (a) obtains and complies with all Region and other permits and authorizations required to perform the proposed work, including where applicable a road occupancy permit;
- (b) except in the case of emergency, notifies the Region a minimum of forty-eight (48) hours before the City's entry;
- (c) shall not enter on or access the Regional Property for any purpose other than fulfilling its obligations or exercise its rights under this Agreement; and

(d) shall at its sole expense restore the Regional Property to the same or better condition as existed immediately prior to the City's entry.

7.5 The City shall make all payments and take all steps necessary to ensure that no lien or notice of claim under the Construction Act is registered against the Regional Lands or is received by the Region, as a result of any works, services, or materials supplied under this Agreement to or for the City. The City shall cause any registration or notice to be discharged or vacated within thirty (30) days after receipt. If the City fails to cause any such lien to be discharged or vacated, then in addition to any other rights and remedies that the Region may have, the Region may discharge or vacate the lien by paying into court the amount claimed as well as any prescribed security, and upon demand the City shall reimburse the Region for all amounts paid including the Region's legal fees and disbursements.

7.6 The City is solely responsible for all risks resulting from the City entering the Regional Property. The Region shall have no liability for the personal injury or death of any person, or damage to any property, that arises out of, or is in any way connected to, the exercise by the City of its access rights under Section 7.4, except to the extent that the personal injury or death of any person or damage to any property was caused by the negligence or willful misconduct of the Region.

7.7 The parties acknowledge that the "Inter-Municipal Communication Protocol in Response to Operational and Water Quality Issues" and the "Inter-Municipal Notification for Emergency/Urgent Valve Isolation" protocols as distributed at the quarterly or semiannually operation partnership meetings apply when accessing the Regional Property and the City Property.

8. INDEMNITY

8.1 The Region covenants and agrees to indemnify, defend and save harmless the City, its Mayor, council members, officers, employees and agents (collectively, the "**City Indemnitees**"), from and against any and all liabilities, suits, claims, demands, fines, actions, costs, losses, expenses, or proceedings of any kind including legal costs on a solicitor and client basis, claims to property damage, personal injury or death, suffered or incurred by any one or more of the City Indemnitees arising out of or in any way connected, directly or indirectly, to:

(a) the Region's exercise of its access rights under Section 7.1;

(b) any negligent act or omission or willful misconduct by the Region in the performance of any of its obligations under this Agreement; and

- (c) any liens under the Construction Act or any related actions or claims brought as a result of the performance by the Region of its obligations or the exercise of its rights under this Agreement.

8.2 The City covenants and agrees to indemnify, defend and save harmless the Region and its Chair, council members, officers, employees and agents (collectively, the “**Regional Indemnitees**”), from and against any and all liabilities, suits, claims, demands, fines, actions, costs, losses, expenses, or proceeding of any kind including legal costs on a solicitor and client basis, claims to property damage, personal injury or death, suffered or incurred by any one or more of the Regional Indemnitees arising out of or in any way connected, directly or indirectly, to:

- (a) the City’s exercise of its access rights under Section 7.4;
- (b) any negligent act or omission or wilful misconduct by the City in the performance of any of its obligations under this Agreement; and
- (c) any liens under the Construction Act or any related actions or claims brought as a result of the performance by the City of its obligations or the exercise of its rights under this Agreement.

8.3 The parties acknowledge that the indemnities set out in Section 8.1 and 8.2 will survive the termination of this Agreement and expire upon the expiration of all applicable limitation periods, including the limitation periods set out in the *Limitations Act, 2002* and the Construction Act.

9. INSURANCE

City’s Insurance

9.1 Throughout the Term, the City shall take out the following insurance with insurance companies licensed to transact business in the Province of Ontario:

- (a) Commercial General Liability insurance with limits of not less than Five Million Dollars (\$5,000,000.00) inclusive per occurrence for bodily and personal injury, death, and damage to property including loss of use. The Commercial General Liability insurance must include Cross Liability & Severability of interest clauses, Owner’s & Contractor’s Protective, Products & Completed Operations coverage (Broad Form) with an aggregate limit of not less than Five Million Dollars (\$5,000,0000). The Region may accept in place of the above mentioned insurance coverage, a combination of primary liability limits and umbrella insurance or excess liability limits which meet the CGL coverage and general aggregate limits noted above;

- (b) Sudden and Accidental Pollution Liability with limits of not less than Two Million Dollars (\$2,000,000.00).

(the “**City’s Insurance**”).

- 9.2 The City shall ensure that the Region is named as an additional insured on the City’s Insurance policy.
- 9.3 The City shall provide evidence of the City’s Insurance in a form that is in all respects satisfactory to the Region’s Insurance and Risk Manager and the City shall maintain the City’s Insurance continuously throughout the Term. The City shall ensure that the City’s Insurance policies are endorsed to provide the Region with not less than thirty (30) days’ written notice in advance of cancellation, change or amendment restricting coverage.
- 9.4 The City shall provide to the Region a certificate of insurance on the Region’s standard “Certificate of Insurance” form evidencing the City’s Insurance.
- 9.5 The City shall be in good standing with the Workplace Safety and Insurance Board. The City shall ensure that any party performing the City’s obligations under this Agreement is in good standing with the Workplace Safety and Insurance Board and carries appropriate Worker’s Safety Insurance Board insurance and the City shall provide the Region with proof of same upon the Region’s written request.

Region’s Insurance

- 9.6 Throughout the Term the Region shall provide the following insurance taken out with insurance companies licensed to transact business in the Province of Ontario:
 - (a) Commercial General Liability insurance with limits of not less than Five Million Dollars (\$5,000,000.00) inclusive per occurrence for bodily and personal injury, death, and damage to property including loss of use. The Commercial General Liability insurance must include Cross Liability & Severability of interest clauses, Owner’s & Contractor’s Protective, Products & Completed Operations coverage (Broad Form) with an aggregate limit of not less than Five Million Dollars (\$5,000,000);. The City may accept in place of the above mentioned insurance coverage, a combination of primary liability limits and umbrella insurance or excess liability limits which meet the CGL coverage and general aggregate limits noted above;
 - (b) Sudden and Accidental Pollution Liability with limits of not less than Two Million Dollars (\$2,000,000.00).

(the “**Region’s Insurance**”).

- 9.7 The Region shall ensure that the City is named as an additional insured on the Region's Insurance.
- 9.8 The Region shall provide evidence of the Region's Insurance in a form that is in all respects satisfactory to the City's Insurance and Risk Manager and the Region shall maintain the Region's Insurance continuously throughout the Term. The Region shall ensure that the Region's Insurance policies are endorsed to provide the City with not less than thirty (30) days' written notice in advance of cancellation, change or amendment restricting coverage.
- 9.9 The Region shall provide to the City a certificate of insurance on the City's standard "Certificate of Insurance" form evidencing the Region's Insurance.
- 9.10 The Region shall be in good standing with the Workplace Safety and Insurance Board. The Region shall ensure that any party performing the Region's obligations under this Agreement is in good standing with the Workplace Safety and Insurance Board and carries appropriate Worker's Safety Insurance Board insurance and the Region shall provide the City with proof of same upon the City's written request.

10. WSIB

- 10.1 The City shall be responsible for and bear the cost of any charges laid by the Ministry of Labour arising from the City's performance or non-performance of the obligations of this Agreement, including reimbursing the Region for any fines or other charges incurred by the Region as a result thereof under the *Workplace Safety and Insurance Act, 1997* or its regulations.
- 10.2 The Region shall be responsible for and bear the cost of any charges laid by the Ministry of Labour arising from the Region's performance or non-performance of the obligations of this Agreement, including reimbursing the City for any fines or other charges incurred by the City as a result thereof under the *Workplace Safety and Insurance Act, 1997* or its regulations.

11. TERM

- 11.1 The term of this Agreement shall commence on the Effective Date, and shall continue in full force and effect unless terminated by either party in accordance with Section 11.2 or 11.3 (the "Term").
- 11.2 Either party may terminate this Agreement, upon providing at least five (5) days' written notice in the event of a breach of this Agreement by the other party after notice thereof and failure of the defaulting party to remedy or cure the breach within thirty (30) days of receipt of the notice.

- 11.1 Either party may terminate this Agreement by providing six (6) months' prior written notice to the other party. If this Agreement is terminated, the parties agree that the Region shall continue to have title to and jurisdiction over the Regional Assets as defined by this Agreement including those transferred to it as a result of this Agreement and the City shall continue to have title and jurisdiction over the City Assets as defined by this Agreement including those transferred to it as a result of this Agreement as of the date of termination.

12. NOTICE

- 12.1 Notices under this Agreement shall be in writing and sent by personal delivery, fax, email, or by registered mail. Notices by registered mail shall be deemed to have been received on the fourth Business Day after the date of mailing. Notices by personal delivery or by fax shall be deemed to have been received at the time of the delivery or transmission, unless delivered or transmitted on a weekend or holiday, in which case such notice shall be deemed to have been received on the next Business Day. In the event of an interruption in postal service, notice shall be given by personal delivery or by fax. The address, contact person and fax of the parties under this Agreement, unless otherwise noted is:

to the Region at:

The Regional Municipality of York
17250 Yonge Street
Newmarket, Ontario
L3Y 6Z1

Attention: Erin Mahoney, Commissioner of Environmental Services
Tel: 905.830.4444 ext. 75125
Fax: 905.895.0260
Email: erin.mahoney@york.ca

to the City at:

Attention: James Steele, Director of Environmental Services
Tel: 905-832-8585 ext. 6116
Email: james.steele@vaughan.ca

13. GENERAL

- 13.1 If any term of this Agreement is found to be invalid, illegal, or unenforceable by a court having the jurisdiction to do so, that term is to be considered to have been severed from this Agreement and this Agreement remains in force unaffected by that finding or by the severance of that term.

- 13.2 No amendments or waiver of any provision of this Agreement binds either party unless consented to in writing by such party. No waiver of any provision of this Agreement constitutes a waiver of any other provision, nor will any waiver constitute a continuing waiver unless expressly provided.
- 13.3 This Agreement is governed by and construed and enforced in accordance with the laws of the Province of Ontario and the laws of Canada which may be applicable to a party in the Province of Ontario and both parties irrevocably attorn to the exclusive jurisdiction of the courts of the Province of Ontario.
- 13.4 This Agreement constitutes the entire agreement between the parties with respect to the subject matter hereof and supersedes any and all prior agreements, negotiations, discussions and understandings whether written or oral, between the parties. Except as provided in this Agreement, there are no conditions, covenants, agreements, representations, warranties, acknowledgements or other provisions, express or implied, collateral, statutory or otherwise, that form part of this Agreement.
- 13.5 This Agreement may be executed in any number of counterparts, each of which is deemed to be an original but all of which taken together constitute an original agreement, and will be effective when one or more counterparts have been signed by each of the parties to the Agreement and deliver to each of the parties.
- 13.6 The parties may sign and deliver this Agreement by fax or electronic transmission and a delivered fax or electronic copy has the same legally binding effect as an original.
- 13.7 The words "include", "includes", "including", and similar formulations, shall in all instances be deemed to be followed by ", without limitation,".

SIGNATURE PAGE FOLLOWS

This Agreement is effective on the Effective Date.

Authorized by:
Report 9 (2) of the Environmental
Services Committee and adopted
by Regional Council at its meeting
held on November 15, 2012.

Approved as to
form and content

Solicitor

THE REGIONAL MUNICIPALITY OF YORK

Erin Mahoney
Commissioner of Environmental Services

**THE CORPORATION OF THE CITY OF
VAUGHAN**

Hon. Maurizio Bevilacqua, Mayor

Todd Coles, City Clerk

SCHEDULE A

REGIONAL OWNERSHIP BOUNDARY FOR WATER AND WASTEWATER INFRASTRUCTURE

TABLE OF CONTENTS

1	INTRODUCTION.....	- 2 -
2	WATERMAIN CONNECTIONS.....	- 2 -
3	WASTEWATER CONNECTIONS	- 3 -
3.1	Forcemain Connections	- 3 -
3.2	Gravity Sewer Connections	- 4 -
3.2.1	Type A Connection.....	- 4 -
3.2.2	Type B Connection.....	- 4 -
3.2.3	Type C Connection	- 5 -
3.2.4	Type D Connection (no longer permitted)	- 6 -
3.2.5	Type E Connection (no longer permitted).....	- 7 -
3.2.6	Type F Connection (no longer permitted).....	- 8 -
4	PRIVATE CONNECTIONS.....	- 9 -
4.1	Connection Type	- 10 -

1 INTRODUCTION

The purpose of this Schedule is to delineate the ownership boundary of Regional water and wastewater infrastructure in the areas of non-exclusive jurisdiction as defined under Section 11 of the *Municipal Act, 2001*. This enables York Region to efficiently manage, operate, maintain, monitor, plan and construct Regional water and wastewater infrastructure assets to meet the *Safe Drinking Water Act, 2002*; the *Ontario Water Resources Act*; the *Clean Water Act, 2006*; the *Environmental Protection Act*; the *Environmental Assessment Act*; the *Water Opportunities and Water Conservation Act, 2010*, and Public Sector Accounting Board standards.

2 WATERMAIN CONNECTIONS

York Region secures and protects drinking water and delivers it in bulk to the nine local municipalities, which in turn distribute it to residents and businesses. York Region collects, treats, stores and distributes water to the Towns of Aurora, East Gwillimbury, Georgina, Newmarket, Whitchurch-Stouffville, the Township of King, and the Cities of Markham, Richmond Hill, and Vaughan via a diverse network of water infrastructure.

Throughout this network are Regional valves which allow Regional Operations staff the ability to control the distribution of water to the local municipalities. Within a Regional valve chamber, the last point of Regional control is at the first branch valve off of the Regional trunk watermain. At Regional valve chambers where a branch local municipal supply watermain exists, Regional jurisdiction ends at the first pipe joint located one to two metres outside of the chamber wall.

Figure 1 depicts the standard Regional watermain connection type and the Regional ownership delineation point where Regional jurisdiction ends.

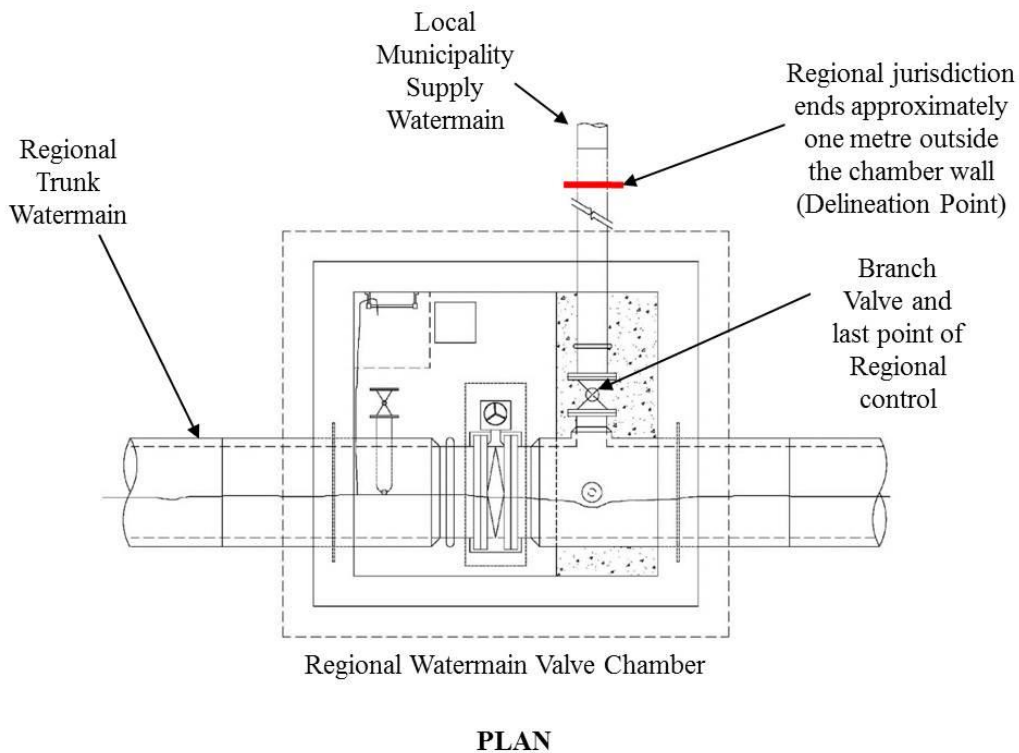

FIGURE 1 - WATERMAIN CONNECTION DELINEATION POINT

3 WASTEWATER CONNECTIONS

The Region is responsible for trunk sewers, transmission forcemains and treatment facilities as part of the two-tier municipal system with its nine local municipalities. The Regional wastewater system is divided into the York Durham Sewage System (YDSS), Peel Diversion System, the Georgina System and five Stand-alone Systems.

3.1 Forcemain Connections

A forcemain is a pressurized pipe that conveys sewage from an upstream pumping station to either a downstream gravity sewer or treatment facility. Local connections to Regional forcemains are not permitted.

3.2 Gravity Sewer Connections

Regional sewers function as the downstream collection and conveyance for local municipal sewage flow. There are a number of different connection methods that local municipal sewer systems have used to enter the Regional sewer system.

Figures 2 to 7 depict existing Regional gravity sewer connection types and the Regional ownership delineation point where Regional jurisdiction ends. Figures 5, 6 and 7 depict historical or legacy connection arrangements that although exist in the system, are no longer permitted due to asset management risks.

3.2.1 Type A Connection

The **Type A** connection illustrated in Figure 2 is the standard and preferred direct maintenance hole connection where the local municipal sewer pipe enters the Regional maintenance hole at the invert within or above the benching. Regional jurisdiction ends just outside the maintenance hole wall.

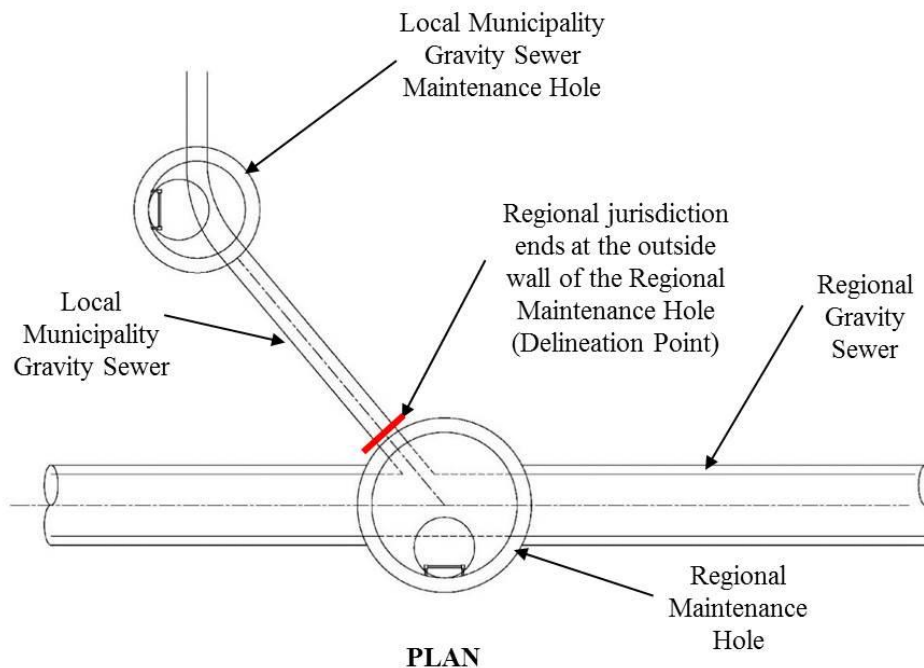

FIGURE 2 – TYPE A CONNECTION DELINEATION POINT

3.2.2 Type B Connection

The **Type B** connection illustrated in Figure 3 occurs at a Regional maintenance hole with an external drop structure that channels flow from a higher elevation to a lower elevation on the outside of the MH wall. This structure enables the local municipality sewer system to remain at shallower depths and drain into deeper Regional sewers. Regional jurisdiction ends at the first

joint upstream of the “Y” connection of the drop pipe since the drop pipe is dowelled and concrete encased as part of the Regional maintenance hole.

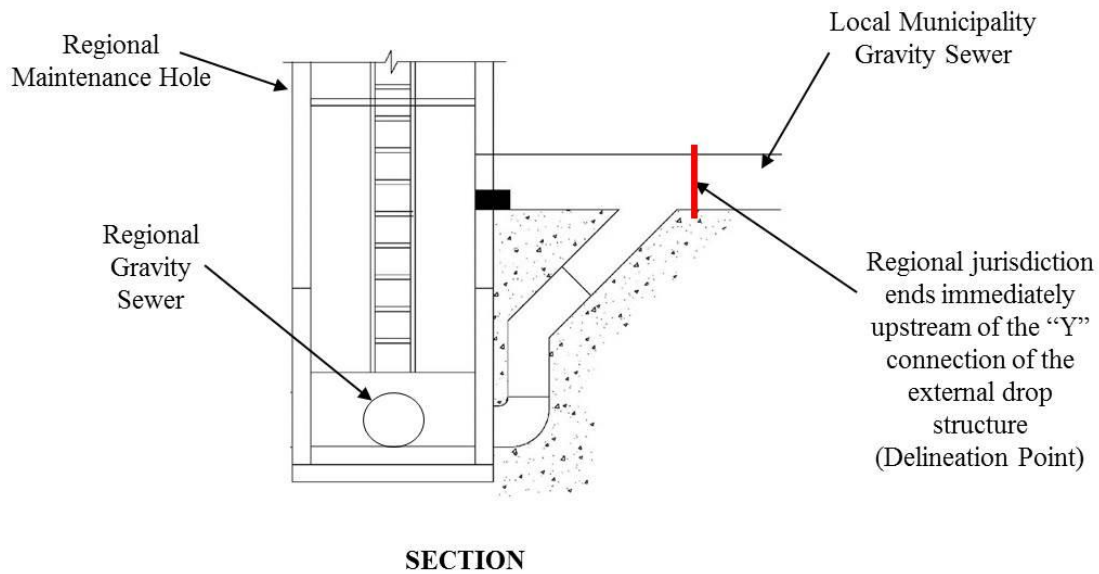

FIGURE 3 – TYPE B CONNECTION DELINEATION POINT

3.2.3 Type C Connection

The **Type C** connection illustrated in Figure 4 occurs at a Regional maintenance hole with an internal drop structure that channels flow from a higher elevation to a lower elevation within the walls of the maintenance hole. This structure enables the local municipal sewer system to remain at shallower depths and drain into the deeper Regional sewers. In this case, Regional jurisdiction ends at the outside wall of the maintenance hole.

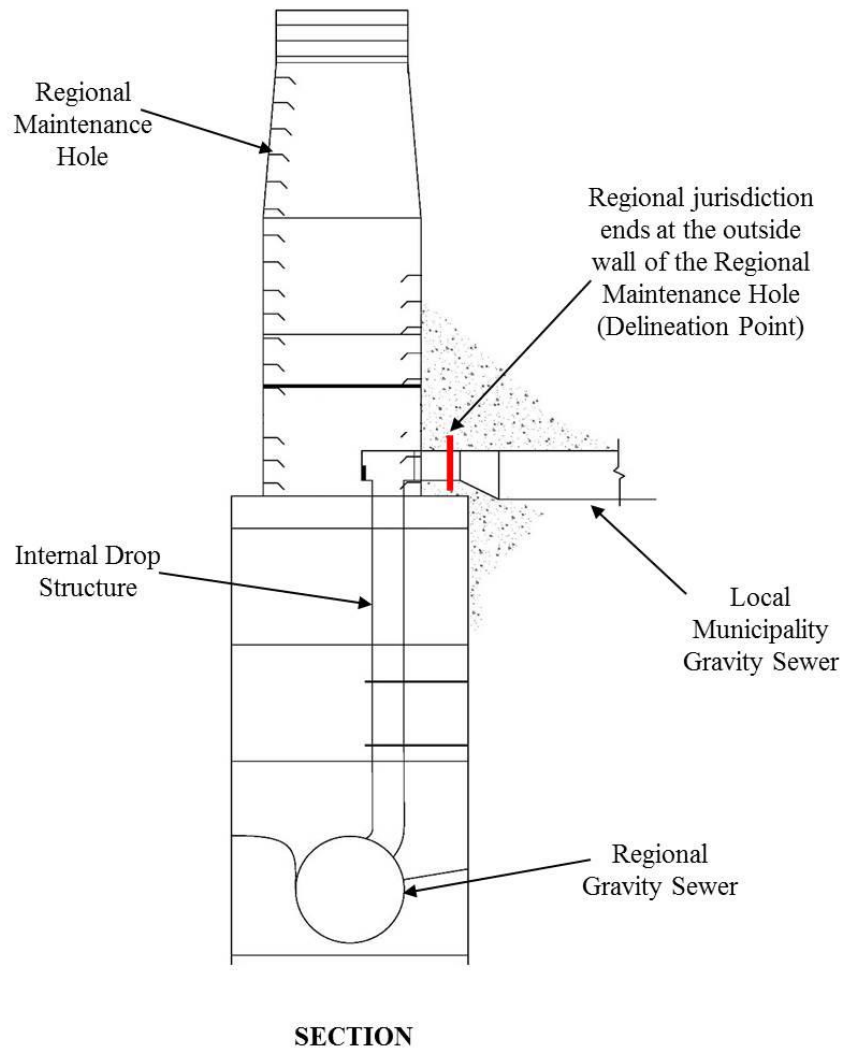

FIGURE 4 – TYPE C CONNECTION DELINEATION POINT

3.2.4 Type D Connection (no longer permitted)

The **Type D** connection illustrated in Figure 5 occurs when there is no Regional maintenance hole in the area and the potential to add a maintenance hole may compromise the integrity of the Region’s gravity sewer. In this case, the Region previously allowed a direct pipe-to-pipe connection with the maintenance hole installed at the edge of the Regional sewer’s permanent easement or offset from the Regional sewer at an appropriate distance. In the case where these legacy connections still exist, the maintenance hole is Regional and Regional jurisdiction ends at the outside wall of the maintenance hole where the local municipality sewer enters. This delineation point allows the Region the ability to access and maintain the pipe-to-pipe connection to the sewer. For clarity, these types of connections are no longer permitted.

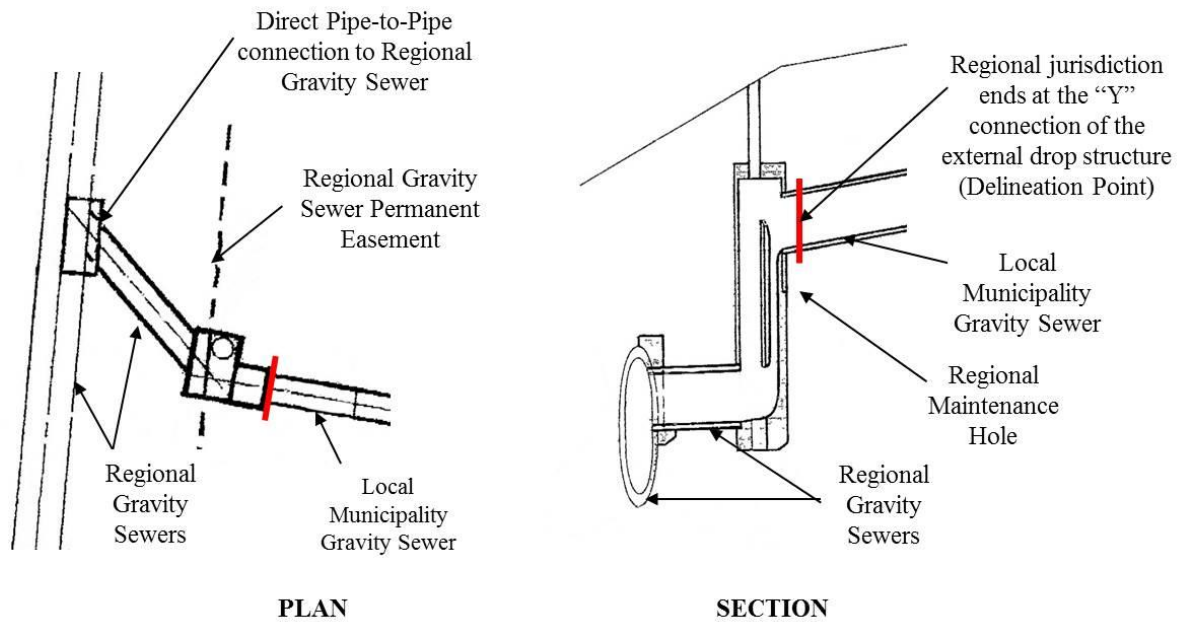

FIGURE 5 – TYPE D CONNECTION DELINEATION POINT (NO LONGER PERMITTED)

3.2.5 Type E Connection (no longer permitted)

The **Type E** connection illustrated in Figure 6 occurs at a Regional maintenance hole with an internal drop shaft that channels flow from a higher elevation to a lower elevation within the walls of the maintenance hole. What differentiates this from Type C connection is that there is no access from the maintenance hole to the Regional gravity sewer. This structure enables the local municipal sewer system to remain at shallower depths and drain into the deeper Regional sewers. In the case where these legacy connections still exist, Regional jurisdiction ends at the outside wall of the maintenance hole. For clarity, these types of connections are no longer permitted.

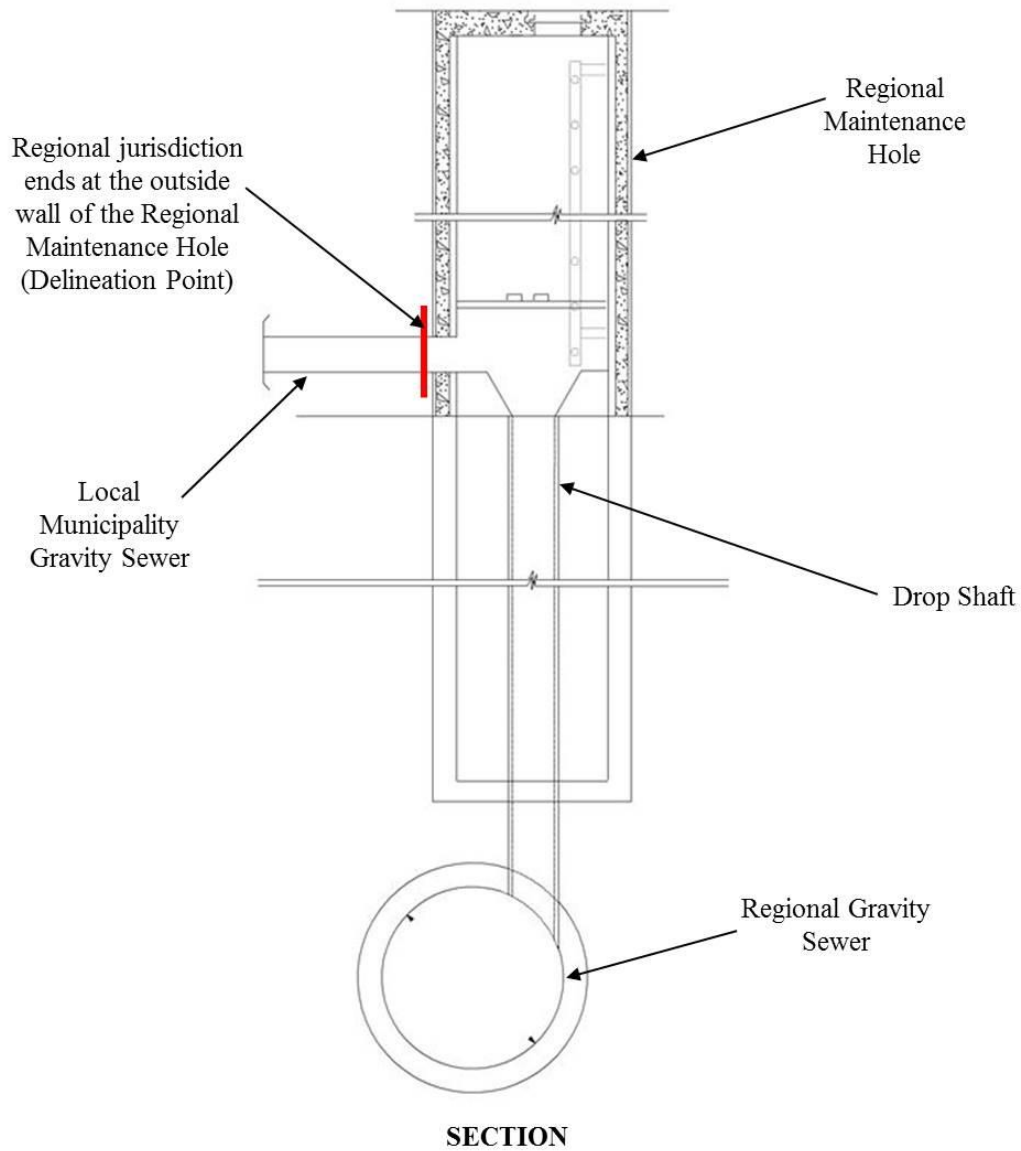

FIGURE 6 – TYPE E CONNECTION DELINEATION POINT (NO LONGER PERMITTED)

3.2.6 Type F Connection (no longer permitted)

The **Type F** connection illustrated in Figure 7 occurs at a Regional maintenance hole with a Vortex Drop Structure that creates a wall-hugging spiral flow in the vertical drop structure to dissipate the energy by friction. This vortex flow is formed by a circular or volute-shaped chamber situated concentrically on top of the vertical drop. Flow is subsequently channeled from a higher elevation to a lower elevation within the maintenance hole. This structure enables the local municipal sewer system to remain at shallower depths and drain into the deeper Regional sewers. In the case where these legacy connections still exist, Regional jurisdiction

ends at the outside wall of the upstream maintenance hole. For clarity, these types of connections are no longer permitted.

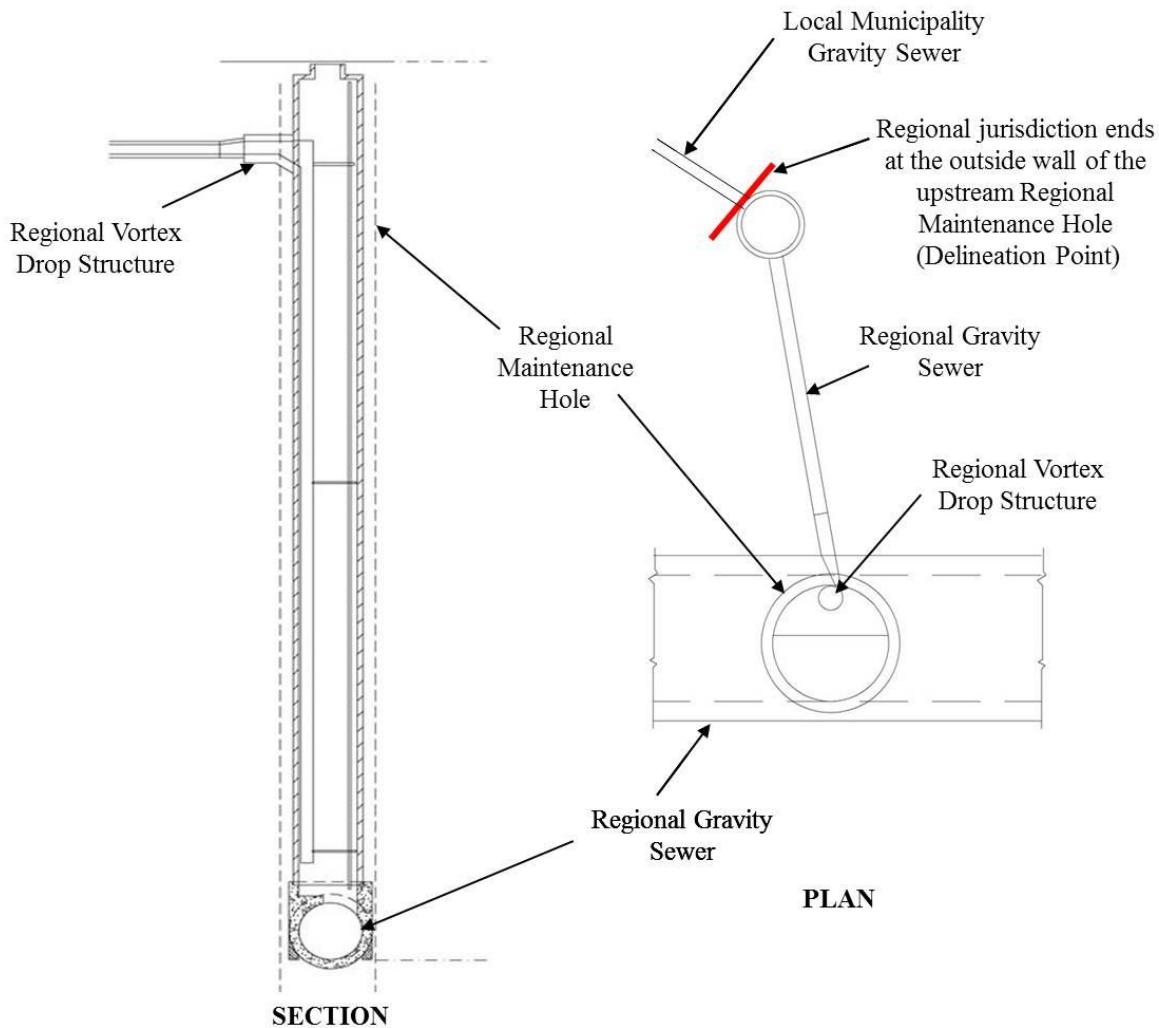

FIGURE 7 – TYPE F CONNECTION DELINEATION POINT (NO LONGER PERMITTED)

4 PRIVATE CONNECTIONS

The Region does not permit private connections into the Region’s water and wastewater infrastructure. Local municipalities must have water and wastewater infrastructure between the Region’s infrastructure and the serviced residents and businesses. The Region is working to remove all existing private connections from the Region’s water and wastewater infrastructure. Until such time, this section details the governing connection type for private connections. No new private connections into the Region’s infrastructure will be permitted due to asset management risks.

When a private water connection directly connects into a pipe or water supply feed from a Regional watermain chamber, Regional jurisdiction ends outside of the pipe or chamber. Private connections at a Regional watermain chamber will be delineated at the outside wall of the Region’s infrastructure at the first joint.

When a private wastewater connection directly connects into a Regional sewer pipe similar to a “Type D” connection and there is no intermediate local municipal infrastructure, Regional jurisdiction ends outside of the pipe. When a private connection is made at a Regional maintenance hole, Regional jurisdiction ends at the outside wall of the maintenance hole.

The following section depicts the standard private connection type and the Regional ownership delineation point where Regional jurisdiction ends.

4.1 Connection Type

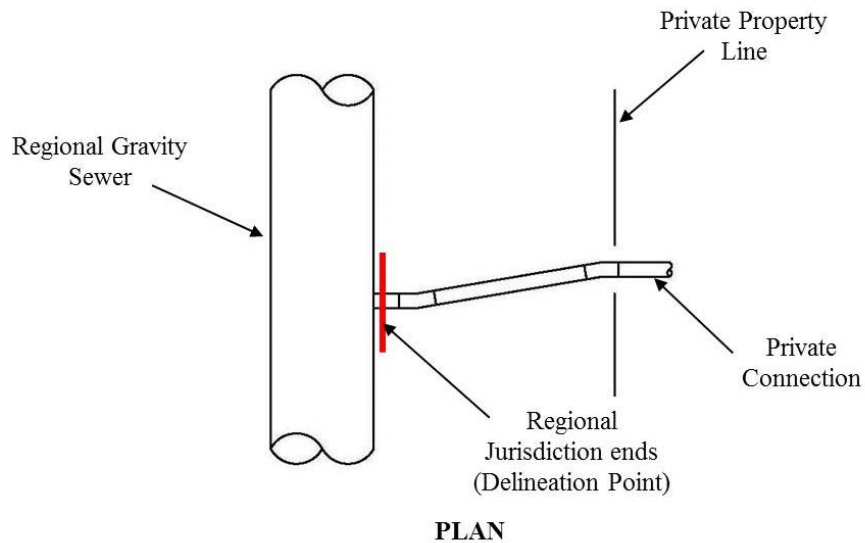

FIGURE 8 – PRIVATE CONNECTION DELINEATION POINT

SCHEDULE B

WATER AND WASTEWATER INFRASTRUCTURE, REGIONAL JURISDICTION POLICY

Water and Wastewater Infrastructure, Regional Jurisdiction Policy

Approved By: Council

Approved On:

Last Reviewed:

POLICY STATEMENT

A policy to establish jurisdiction over Regional water and wastewater infrastructure.

APPLICATION

This policy applies to York Region and its Local Municipalities. This policy does not apply to privately owned and operated water and wastewater systems including those systems operating under Municipal Responsibility Agreements.

PURPOSE

This policy establishes criteria to define the extent of Regional water and wastewater infrastructure in the areas of non-exclusive jurisdiction as defined under Section 11 of the *Municipal Act, 2001* and as summarized below. This enables York Region to efficiently manage, operate, maintain, monitor, plan and construct Regional water and wastewater infrastructure to meet legislative and regulatory requirements including:

- *Safe Drinking Water Act, 2002*
- *Ontario Water Resources Act*
- *Clean Water Act, 2006*
- *Environmental Protection Act*
- *Environmental Assessment Act*
- *Water Opportunities Act, 2010*
- *Public Sector Accounting Board standards, as amended from time to time*

DEFINITIONS

Local Municipality: Refers to one of the nine lower-tier municipalities within York Region, the upper-tier municipality. Specifically, Town of Aurora, Town of East Gwillimbury, Town of Georgina, Township of King, City of Markham, Town of Newmarket, City of Richmond Hill, City of Vaughan and Town of Whitchurch-Stouffville.

Municipal Responsibility Agreements: Refers to legal agreements between York Region and the owner of private communal sewage and/or water services, which stipulate how the communal services are constructed, operated and maintained, the action to be taken in the event of default, as well as provisions to ensure a reserve fund is available in the event the Region is required to operate or assume ownership of the communal services.

Regional Water Infrastructure: Infrastructure for the purposes of delivering drinking water services to the nine Local Municipalities as defined by the criteria in this policy.

Regional Wastewater Infrastructure: Infrastructure for the purposes of delivering wastewater services to the nine Local Municipalities as defined by the criteria in this policy.

Water and Wastewater Asset Ownership Agreements: Signed legal agreements with each Local Municipality that:

- Delineates the ownership boundary of Regional water and wastewater infrastructure
- Establishes requirements for the transfer of asset ownership
- Establishes access rights over Regional Water and Wastewater Infrastructure and local water and wastewater infrastructure

DESCRIPTION

Jurisdiction over water and wastewater infrastructure in York Region is governed by Section 11 of the *Municipal Act, 2001*. Ownership and responsibility of water and wastewater services are shared between Local Municipalities and York Region.

- York Region has exclusive jurisdiction over water production, treatment and storage
- York Region has non-exclusive jurisdiction over:
 - Sewage treatment
 - Collection of sanitary sewage
 - Water distribution

This policy provides criteria to define Regional water and wastewater infrastructure in the areas of non-exclusive jurisdiction.

Water Distribution Criteria

Section 89 of the *Municipal Act, 2001* provides that York Region shall only distribute drinking water to Local Municipalities who in turn distribute to residents and businesses.

Regional water infrastructure provides at least one of the following essential functions:

1. Metering to determine inter-municipal flow information
2. Distribution in the form of watermains and pumping stations whose purpose is to transmit bulk water supply to Local Municipalities

Sanitary Sewage Collection and Treatment Criteria

Regional wastewater infrastructure provides at least one of the following essential functions:

1. Metering to determine inter-municipal flow information
2. Collection in the form of sanitary sewers, forcemains and pumping stations whose purpose is to transmit wastewater from Local Municipalities to a treatment facility. York Region shall only collect wastewater from the Local Municipalities who in turn collect from residents and businesses
3. Treatment of wastewater prior to discharge to the natural environment

Delineation of Water and Wastewater Infrastructure

York Region and Local Municipalities delineate ownership boundaries through Water and Wastewater Asset Ownership Agreements.

RESPONSIBILITIES

Environmental Services Department:

- Oversee and ensure that the Water and Wastewater Infrastructure, Regional Jurisdiction Policy is implemented.
- Implement, manage and amend Water and Wastewater Asset Ownership Agreements with Local Municipalities as required. The Commissioner of Environmental Services has authority to execute and amend Water and Wastewater Asset Ownership Agreements as approved in Council Report No. 9 of Environmental Services Committee November 15, 2012.
- Recommend to Council water and wastewater infrastructure jurisdictional transfer(s) based on the criteria outlined in this policy.
- Develop and implement water and wastewater infrastructure jurisdictional transfer processes and procedures with Local Municipalities.
- Ensure newly constructed water and wastewater infrastructure jurisdiction is delineated and defined.
- Engage Local Municipalities to build consensus on water and wastewater infrastructure delineation.

Corporate Services Department:

- Make reasonable efforts to own or purchase land and/or easements, in accordance with the Corporate Land Acquisition Policy, on which Regional Water and Wastewater Infrastructure is located or will be located.
- Ensure the Regional Official Plan, its amendments and other Corporate Strategies comply with the policy as required.

Legal and Court Services Department:

- Prepare legal documents required to support policy implementation including:
 - Water and Wastewater Asset Ownership Agreements with Local Municipalities
 - Bylaws to support water and wastewater infrastructure jurisdictional transfers
 - Land Transfer Agreements

COMPLIANCE

Existing water and wastewater infrastructure that does not comply with this policy shall be identified and transfer(s) recommended through the Water and Wastewater Asset Ownership Agreement.

REFERENCE

Legislative and other authorities

- *Municipal Act, 2001*
- Corporate Land Acquisition Policy

CONTACT

Director, Infrastructure Asset Management, Environmental Services Department

APPROVAL

Council Date: [REDACTED]	Committee Date: [REDACTED]
Council Minute Item: [REDACTED]	Committee Minute Item: [REDACTED]

Accessible formats or communication supports are available upon request.