

ITEM: 6.11	REPORT SUMMARY MINOR VARIANCE APPLICATION FILE NUMBER A029/26
-------------------	--

Report Date: April 24, 2026

**THIS REPORT CONTAINS COMMENTS FROM THE FOLLOWING
DEPARTMENTS & AGENCIES (SEE SCHEDULE B):**

Additional comments from departments and agencies received after the publication of the report will be made available on the City's [website](#).

Internal Departments *Comments Received	Conditions Required		Nature of Comments
Committee of Adjustment	Yes <input type="checkbox"/>	No <input checked="" type="checkbox"/>	General Comments
Building Standards (Zoning)	Yes <input type="checkbox"/>	No <input checked="" type="checkbox"/>	General Comments
Development Planning	Yes <input type="checkbox"/>	No <input checked="" type="checkbox"/>	Recommend Approval/No Conditions
Development Engineering	Yes <input type="checkbox"/>	No <input checked="" type="checkbox"/>	Recommend Approval/No Conditions
Forestry	Yes <input type="checkbox"/>	No <input checked="" type="checkbox"/>	General Comments
Development Finance	Yes <input type="checkbox"/>	No <input checked="" type="checkbox"/>	General Comments

External Agencies *Comments Received	Conditions Required		Nature of Comments *See Schedule B for full comments
Alectra	Yes <input type="checkbox"/>	No <input checked="" type="checkbox"/>	General Comments
TRCA	Yes <input type="checkbox"/>	No <input checked="" type="checkbox"/>	General Comments
Region of York	Yes <input type="checkbox"/>	No <input checked="" type="checkbox"/>	General Comments

PUBLIC & APPLICANT CORRESPONDENCE (SEE SCHEDULE C)				
<p>All personal information collected because of this public meeting (including both written and oral submissions) is collected under the authority of the Municipal Act, the Municipal Freedom of Information and Protection of Privacy Act (MFIPPA), the Planning Act and all other relevant legislation, and will be used to assist in deciding on this matter. All personal information (as defined by MFIPPA), including (but not limited to) names, addresses, opinions and comments collected will become property of the City of Vaughan, will be made available for public disclosure (including being posted on the internet) and will be used to assist the Committee of Adjustment and staff to process this application.</p>				
Correspondence Type	Name	Address	Date Received (mm/dd/yyyy)	Summary
None				

BACKGROUND (SCHEDULE D, IF REQUIRED)	
<p>* Background Information contains historical development approvals considered to be related to this file. This information should not be considered comprehensive.</p>	
Application No. (City File)	Application Description (i.e. Minor Variance Application; Approved by COA / OLT)
N/A	N/A

ADJOURNMENT HISTORY	
<p>* Previous hearing dates where this application was adjourned by the Committee and public notice issued.</p>	
Hearing Date	Reason for Adjournment (to be obtained from NOD_ADJ)
N/A	N/A

SCHEDULES	
Schedule A	Drawings & Plans Submitted with the Application
Schedule B	Comments from Agencies, Building Standards & Development Planning
Schedule C (if required)	Public & Applicant Correspondence
Schedule D (if required)	Background



MINOR VARIANCE APPLICATION FILE NUMBER A029/26

CITY WARD #:	2
APPLICANT:	Antony Segreto & Georgia Maria Tsoromocos
AGENT:	Square Design Group
PROPERTY:	83 Ayton Crescent, Woodbridge
ZONING DESIGNATION:	See below.
VAUGHAN OFFICIAL PLAN (2010) DESIGNATION:	Vaughan Official Plan ('VOP 2010'): "Low-Rise Residential"
RELATED DEVELOPMENT APPLICATIONS:	None
PURPOSE OF APPLICATION:	Relief from the Zoning By-law is being requested to permit a proposed cabana and retaining wall in the rear/side yard.

The following variances are being requested from the City's Zoning By-law to accommodate the above proposal:

The subject lands are zoned R1B(EN) – First Density Residential Zone (Established Neighbourhood) and subject to the provisions of Exception 14.493 under Zoning By-law 001-2021, as amended.

#	Zoning By-law 001-2021	Variance requested
1	An accessory building or structure with a height of 2.8 m or greater shall be setback a minimum of 2.16 m to the rear lot line. [Section 4.1.2 1b and Bill 17]	To permit an accessory structure (Cabana) with a height of 2.8m or greater to be setback a minimum of 2.00 m to the rear lot line.
2	An accessory building or structure with a height of 2.8 m or greater shall be setback a minimum of 4.05 m to the exterior side lot line. [Section 4.1.2 1b and Bill 17]	To permit an accessory structure (Cabana) with a height of 2.8m or greater to be setback a minimum of 1.33 m to the exterior side lot line.
3	In any Residential Zone, the maximum height of an accessory building or structure shall be 3.0 m . [Section 4.1.4.1.]	To permit a maximum height of 3.11 m for an accessory structure (Cabana).
4	Eaves, eavestroughs, and gutters are permitted to encroach a maximum of 0.6 m into any required yard. [Section 4.13, Table 4-1]	To permit Eaves, eavestroughs, and gutters to encroach a maximum of 0.65 m into the minimum required exterior side yard.
5	Eaves, eavestroughs, and gutters are permitted to encroach a maximum of 0.6 m into any required yard. [Section 4.13, Table 4-1]	To permit Eaves, eavestroughs, and gutters to encroach a maximum of 0.61 m into the minimum required rear yard.
6	A retaining wall shall be setback an equal distance to the height of the highest portion of the retaining wall. [Section 4.13, Table 4-1]	To permit a retaining wall with a maximum height of 1.0 m to be setback a minimum of 0.45 m from the rear lot line.

HEARING INFORMATION

DATE OF MEETING: Thursday, April 30, 2026
TIME: 6:00 p.m.
MEETING LOCATION: Vaughan City Hall, Woodbridge Room (2nd Floor), 2141 Major Mackenzie Drive
LIVE STREAM LINK: Vaughan.ca/LiveCouncil

PUBLIC PARTICIPATION

If you would like to speak to the Committee of Adjustment at the meeting, either remotely or in person, please complete the [Request to Speak Form](#) and submit to cofa@vaughan.ca

HEARING INFORMATION

If you would like to submit written comments, please quote file number above and submit by mail or email to:

Email: cofa@vaughan.ca

Mail: City of Vaughan, Office of the City Clerk, Committee of Adjustment, 2141 Major Mackenzie Drive, Vaughan, ON, L6A 1T1

To speak electronically, pre-registration is required by completing the [Request to Speak Form](#) on-line and submitting it to cofa@vaughan.ca no later than NOON on the last business day before the meeting.

THE DEADLINE TO REGISTER TO SPEAK ELECTRONICALLY OR SUBMIT WRITTEN COMMENTS ON THE ABOVE NOTED FILE(S) IS NOON ON THE LAST BUSINESS DAY BEFORE THE MEETING.

INTRODUCTION

Staff and Agencies act as advisory bodies to the Committee of Adjustment. The comments contained in this report are presented as recommendations to the Committee.

Section 45(1) of the Planning Act sets the criteria for authorizing minor variances to the City of Vaughan's Zoning By-law. Accordingly, review of the application may consider the following:

- That the general intent and purpose of the by-law will be maintained.
- That the general intent and purpose of the official plan will be maintained.
- That the requested variance(s) is/are acceptable for the appropriate development of the subject lands.
- That the requested variance(s) is/are minor in nature.

Public written and oral submissions relating to this application are taken into consideration by the Committee of Adjustment as part of its deliberations and final decision on this matter.

COMMITTEE OF ADJUSTMENT

Date Public Notice Mailed:	April 16, 2026
Date Applicant Confirmed Posting of Sign:	April 14, 2026
Applicant Justification for Variances: <small>*As provided in Application Form</small>	Does not comply with setbacks
Was a Zoning Review Waiver (ZRW) Form submitted by Applicant: <small>*ZRW Form may be used by applicant in instances where a revised submission is made, and zoning staff do not have an opportunity to review and confirm variances prior to the issuance of public notice.</small>	Yes <input type="checkbox"/> No <input checked="" type="checkbox"/>
COMMENTS:	
None	
Committee of Adjustment Recommended Conditions of Approval:	None

BUILDING STANDARDS (ZONING)

**See Schedule B for Building Standards (Zoning) Comments	
Building Standards Recommended Conditions of Approval:	None

DEVELOPMENT PLANNING

**See Schedule B for Development Planning Comments.	
Development Planning Recommended Conditions of Approval:	None

DEVELOPMENT ENGINEERING

[Link to Grading Permit](#) [Link to Pool Permit](#) [Link to Curb Curt Permit](#) [Link Culvert Installation](#)

Development Engineering has reviewed the Minor Variance application A029/26. An approved Grading Permit has been issued by the Development Engineering Department for the subject property on January 7, 2026, which addresses site grading, drainage, and surface water management for the proposed cabana. The approved grading plan demonstrates that adequate drainage provisions have been incorporated to ensure surface water runoff from the proposed structures does not negatively

DEVELOPMENT ENGINEERING

[Link to Grading Permit](#) [Link to Pool Permit](#) [Link to Curb Curt Permit](#) [Link Culvert Installation](#)

impact adjacent properties. The Owner/Applicant shall ensure that all grading and construction activities are carried out in accordance with the approved Grading Permit and associated grading plan. Any modifications to the approved grading design must be reviewed and approved by the Development Engineering Department prior to implementation. The Development Engineering Department does not object to the Minor Variance application A029/26.

Development Engineering Recommended Conditions of Approval:	None
--	------

PARKS, FORESTRY & HORTICULTURE (PFH)

No comments received to date

PFH Recommended Conditions of Approval:	None
--	------

DEVELOPMENT FINANCE

No comment no concerns

Development Finance Recommended Conditions of Approval:	None
--	------

BY-LAW AND COMPLIANCE, LICENSING AND PERMIT SERVICES

No objection or comments

BCLPS Recommended Conditions of Approval:	None
--	------

BUILDING INSPECTION (SEPTIC)

No comments received to date

Building Inspection Recommended Conditions of Approval:	None
--	------

FIRE DEPARTMENT

No comments received to date

Fire Department Recommended Conditions of Approval:	None
--	------

IMPORTANT INFORMATION

CONDITIONS: It is the responsibility of the owner/applicant and/or authorized agent to obtain and provide a clearance letter from respective department and/or agency (**see condition chart above for contact**). This letter must be provided to the Secretary-Treasurer to be finalized. All conditions must be cleared prior to the issuance of a Building Permit.

APPROVALS: Making any changes to your proposal after a decision has been made may impact the validity of the Committee's decision.

An approval obtained from the Committee of Adjustment, where applicable, is tied to the building envelope shown on the plans and drawings submitted with the application and subject to the variance approval.

A building envelope is defined by the setbacks of the buildings and/or structures shown on the plans and drawings submitted with the application, as required by Ontario Regulation 200/96. Future development outside of an approved building envelope, where a minor variance was obtained, must comply with the provisions of the City's Zoning By-law.

Elevation drawings are provided to reflect the style of roof (i.e. flat, mansard, gable etc.) to which a building height variance has been applied. Where a height variance is approved, building height is applied to the style of roof (as defined in the City's Zoning By-law) shown on the elevation plans submitted with the application.

Architectural design features that are not regulated by the City's Zoning By-law are not to be considered part of an approval unless specified in the Committee's decision.

DEVELOPMENT CHARGES: That the payment of the Regional Development Charge, if required, is payable to the City of Vaughan before issuance of a building permit in accordance with the Development Charges Act and the Regional Development Charges By-law in effect at the time of payment.

IMPORTANT INFORMATION

That the payment of the City Development Charge, if required, is payable to the City of Vaughan before issuance of a building permit in accordance with the Development Charges Act and the City's Development Charges By-law in effect at the time of payment.

That the payment of the Education Development Charge if required, is payable to the City of Vaughan before issuance of a building permit in accordance with the Development Charges Act and the Boards of Education By-laws in effect at the time of payment

That the payment of Special Area Development charge, if required, is payable to the City of Vaughan before issuance of a building permit in accordance with the Development Charges Act and The City's Development Charge By-law in effect at the time of Building permit issuance to the satisfaction of the Reserves/Capital Department.

NOTICE OF DECISION: If you wish to be notified of the decision in respect to this application or a related Ontario Land Tribunal (OLT) hearing you must complete a Request for Decision form and submit to the Secretary Treasurer (ask staff for details). In the absence of a written request to be notified of the Committee's decision you will **not** receive notice.

SCHEDULE A: DRAWINGS & PLANS

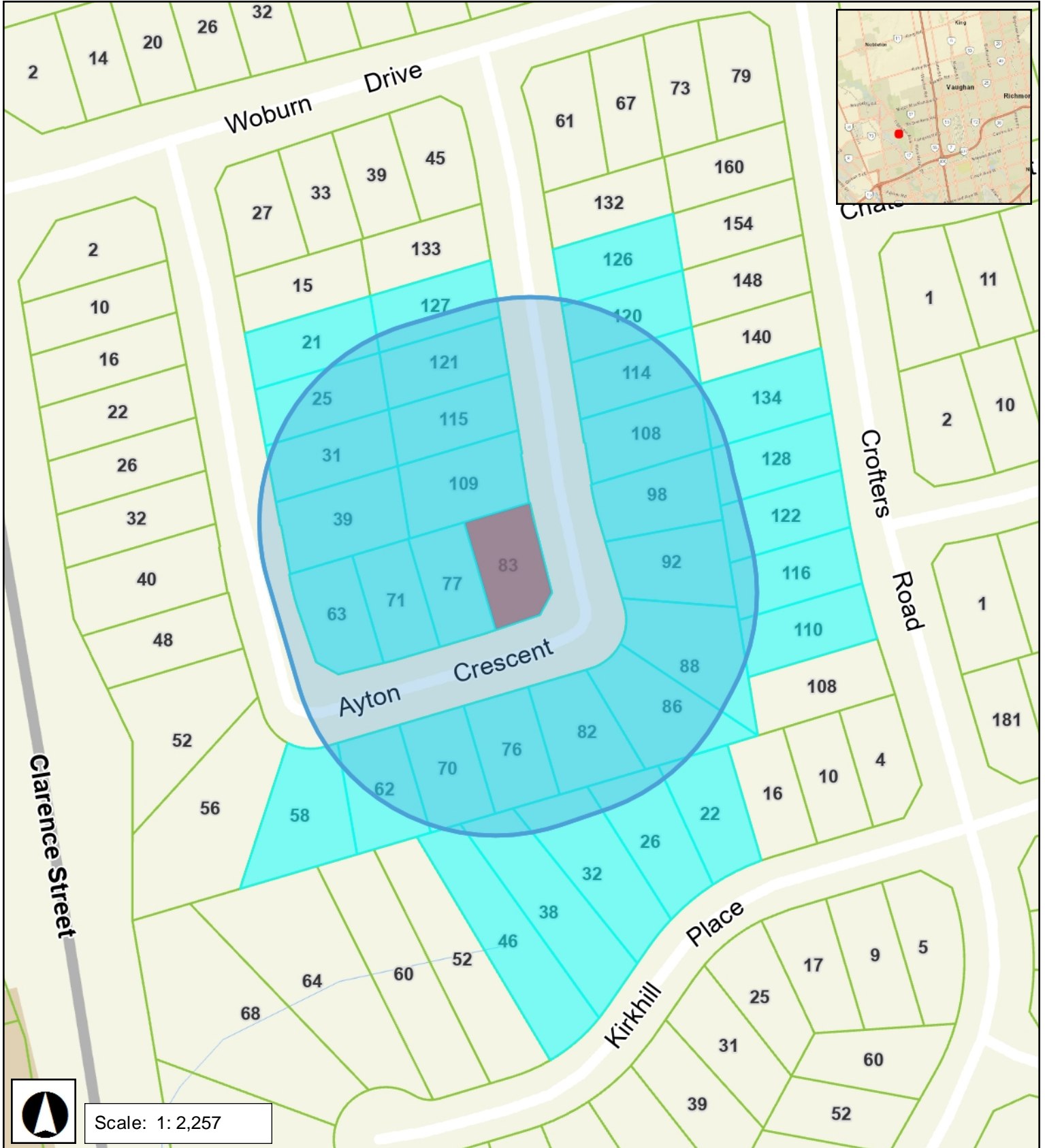

Scale: 1: 2,257

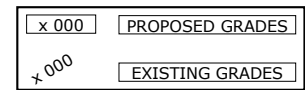
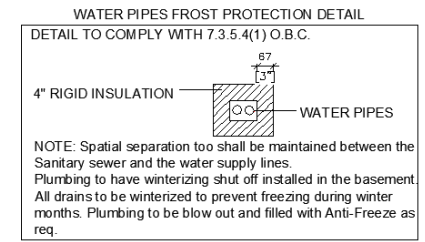
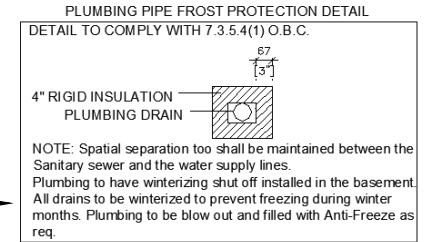
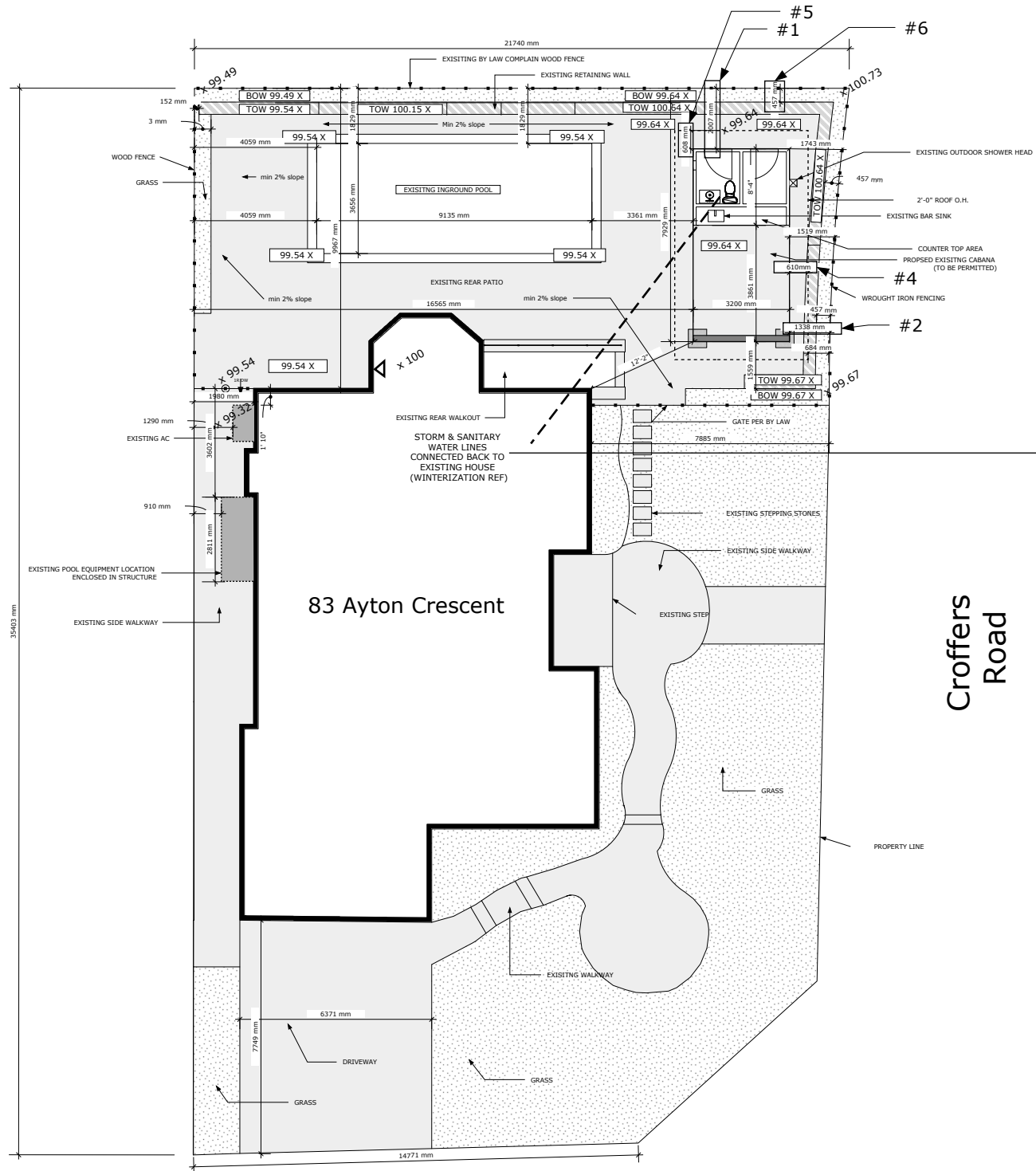
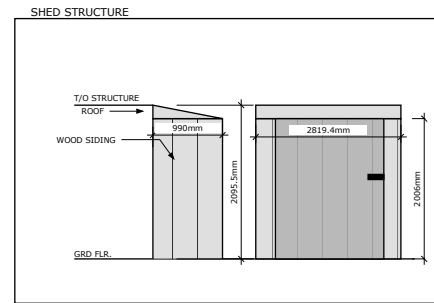

Rear Yard Area Summary	
Total Rear Yard Area:	159.41sqm
Rear Yard Hardscape (Including Pool):	138.81 sqm
Rear Yard Soft Landscape:	20.6 sqm
Required Soft Landscape Area: [(159.41sqm-135sqm) x 60%]	=14.64sqm
Cabana Area:	20.5 sqm / 2.84% Lot Coverage
House Area:	190.9 sqm / 26.45% Lot Coverage
Total Lot Area:	721.5 sqm

1 SITE PLAN
1:200

Ayton Crescent

SITE PLAN

83 Ayton Crescent, Woodbridge, ON L4L 7H8

Scale: 1:50
Date: 04/09/2026

A2



Contractors must verify all dimensions and conditions on the project and must report any discrepancies to the designer before proceeding with construction. Construction, Site Information and Planting Plans must only be used for budgetary pricing. The material and information is for general information and is solely to help the contractor price the concept design.

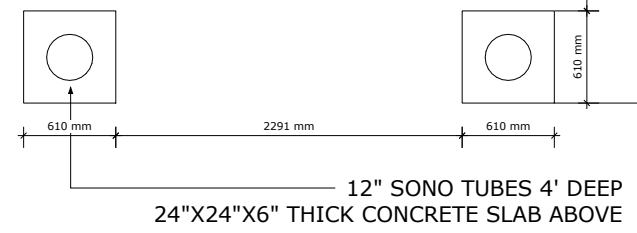
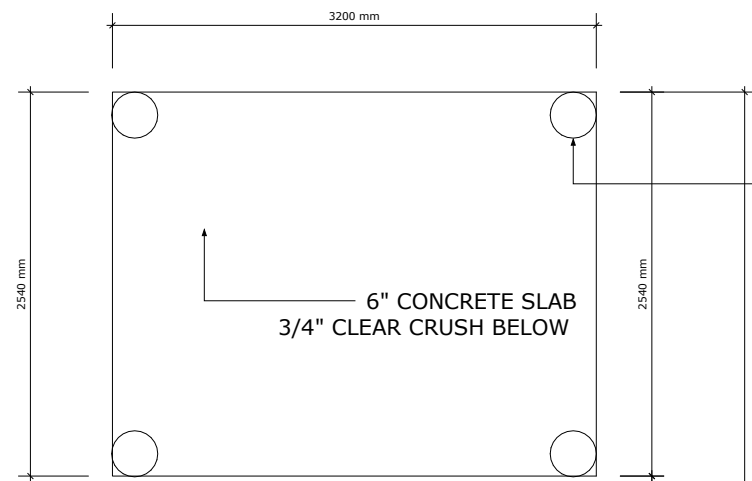

12" SONO TUBES 4' DEEP

6" CONCRETE SLAB
3/4" CLEAR CRUSH BELOW

W1
2X6 STUDS AT 16" O.C
SIL PLATE TO BE
ANCORED AT 24" O.C

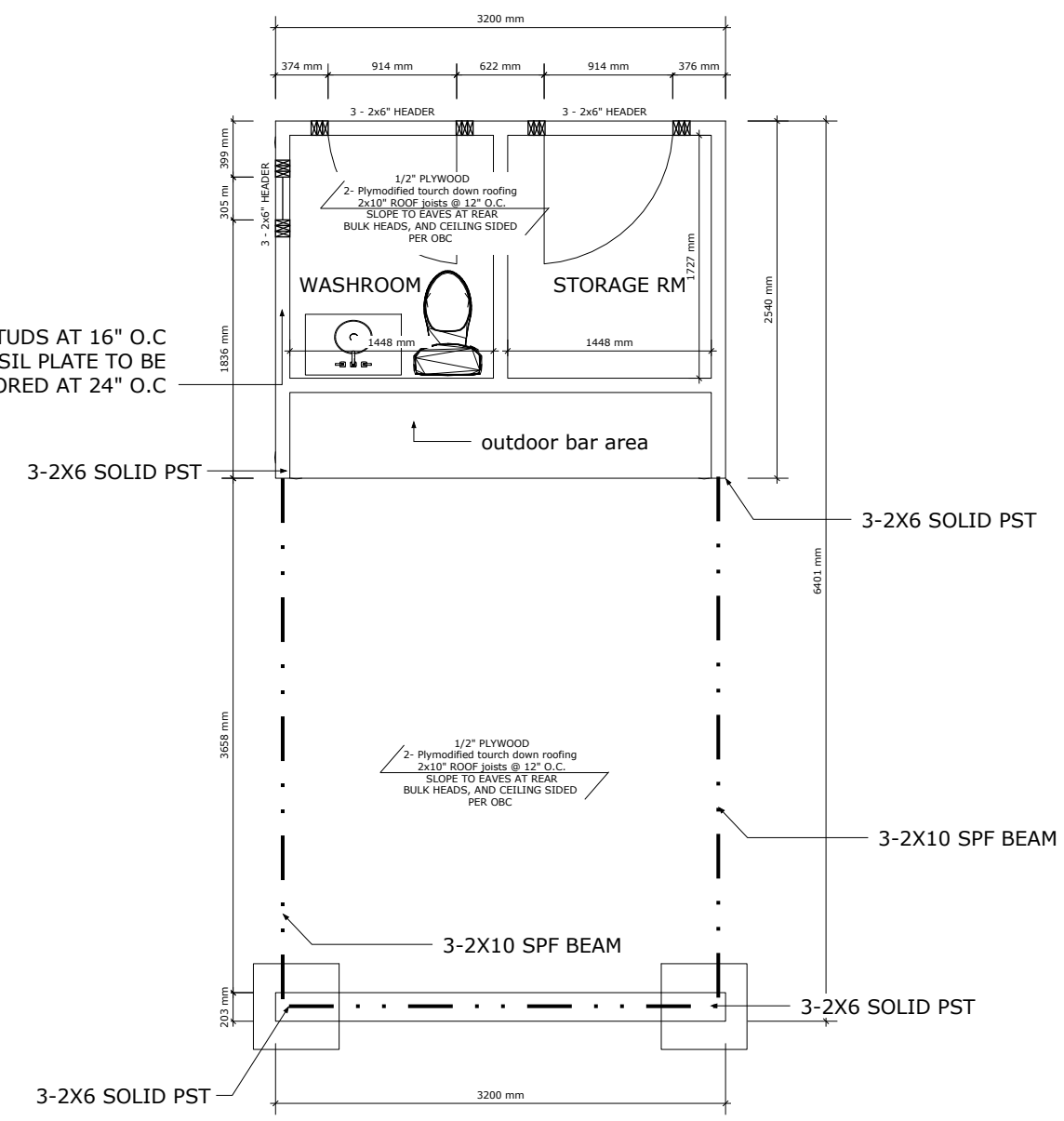

EXTERIOR WALL (Siding)
1X4" CLEAR CEDAR or SIDING
2X6" SPF WOOD STUDS @ 16" O.C.
DBL. TOP PLATE
1X4" CLEAR CEDAR or SIDING

W1

1 FOUNDATION PLAN
1:50

2 FLOOR PLAN
1:50

FLOOR PLANS

83 Ayton Crescent, Woodbridge, ON L4L 7H8

Scale: 1:50
Date: 01/22/2026

A3

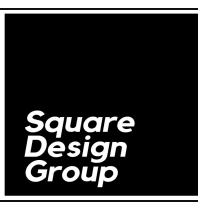

Contractors must verify all dimensions and conditions on the project and must report any discrepancies to the designer before proceeding with construction. Construction, Site Information and Planting Plans must only be used for budgetary pricing. The material and information is for general information and is solely to help the contractor price the concept design.

RIM BOARD TO MATCH JOISTS



joist size per plan

JOIST DIRECTION USE HANGERS AS REQUIRED

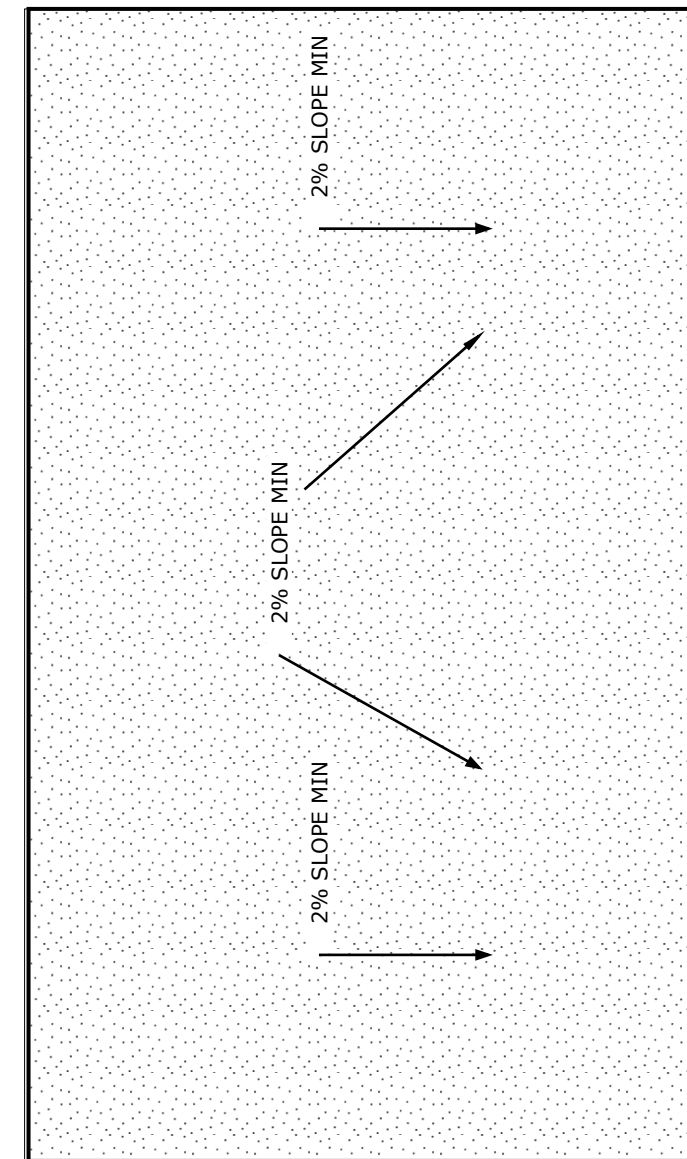

EAVESTROUGH

2% SLOPE MIN

2% SLOPE MIN

2% SLOPE MIN

1 ROOF FRAMING
1:50

2 ROOF DRAINAGE
1:50

FLOOR PLANS

83 Ayton Crescent, Woodbridge, ON L4L 7H8

Scale: 1:50
Date: 01/22/2026

A4

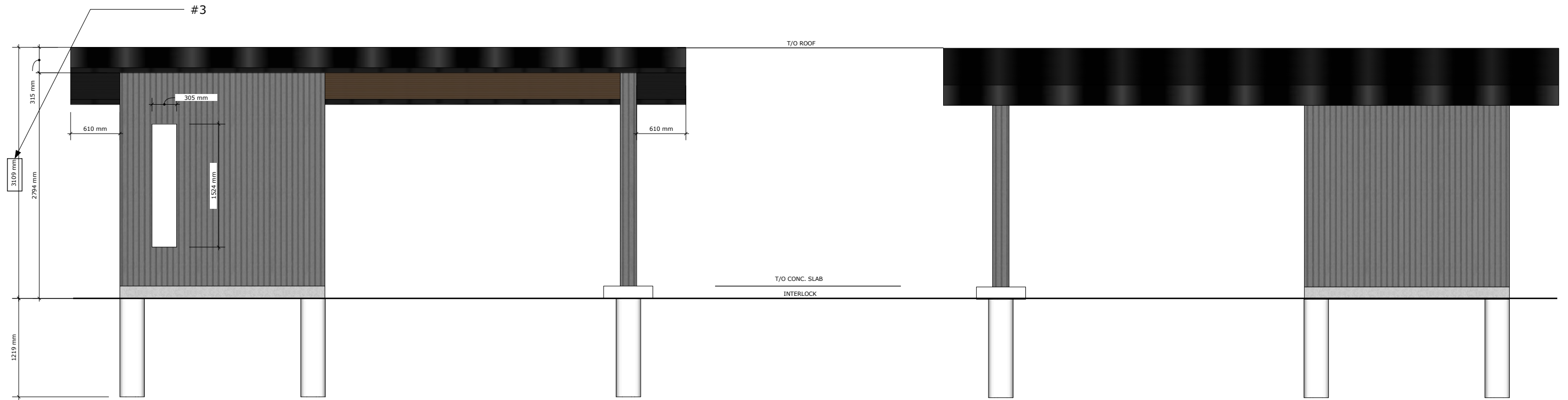

1 WEST ELEVATION
1:50

2 EAST ELEVATION
1:50

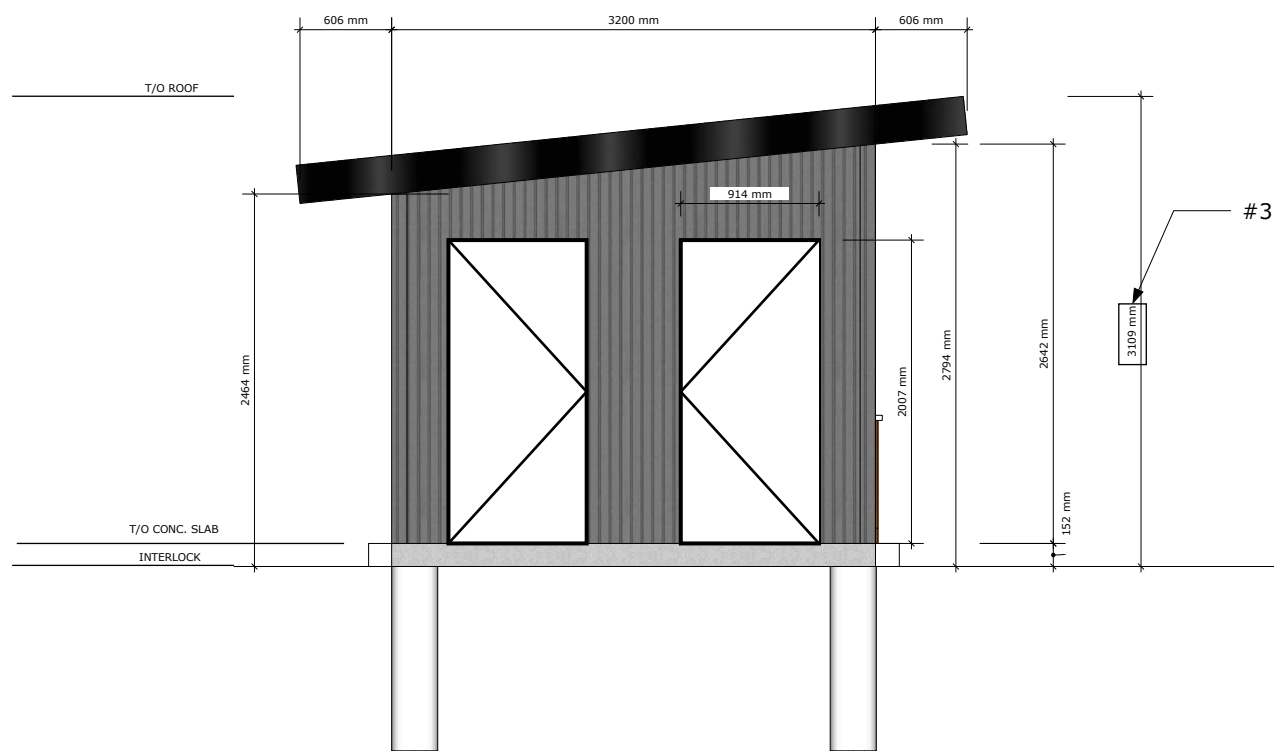

1 NORTH ELEVATION
1:50

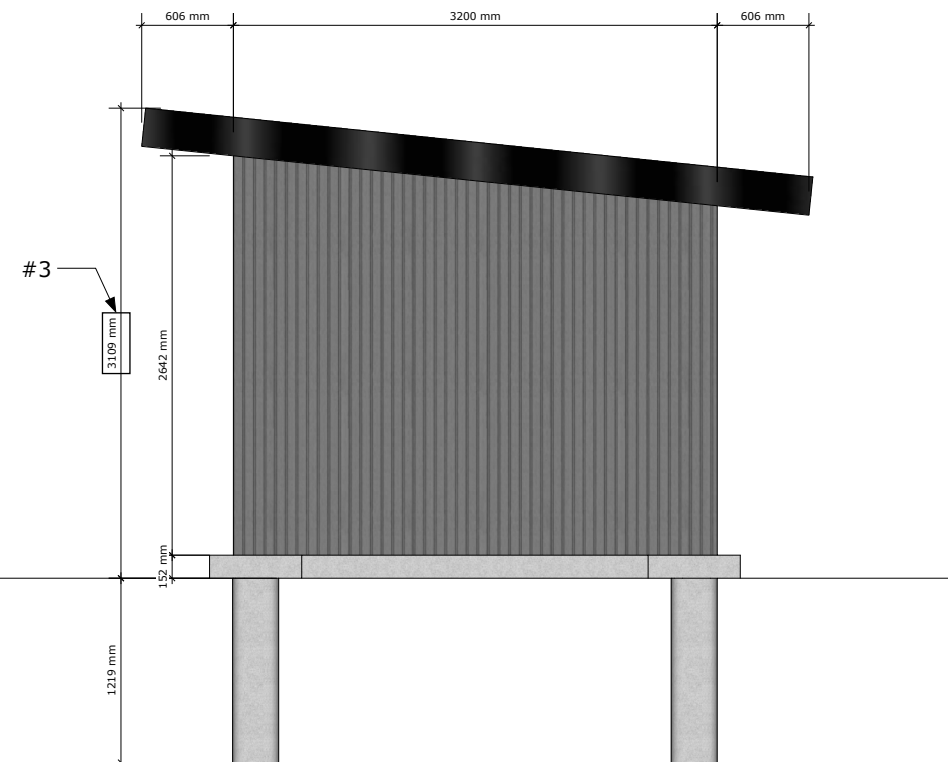

2 SOUTH ELEVATION
1:50



Contractors must verify all dimensions and conditions on the project and must report any discrepancies to the designer before proceeding with construction. Construction, Site Information and Planting Plans must only be used for budgetary pricing. The material and information is for general information and is solely to help the contractor price the concept design.

FLOOR PLANS

83 Ayton Crescent, Woodbridge, ON L4L 7H8

Scale: 1:50
Date: 01/22/2026

A6

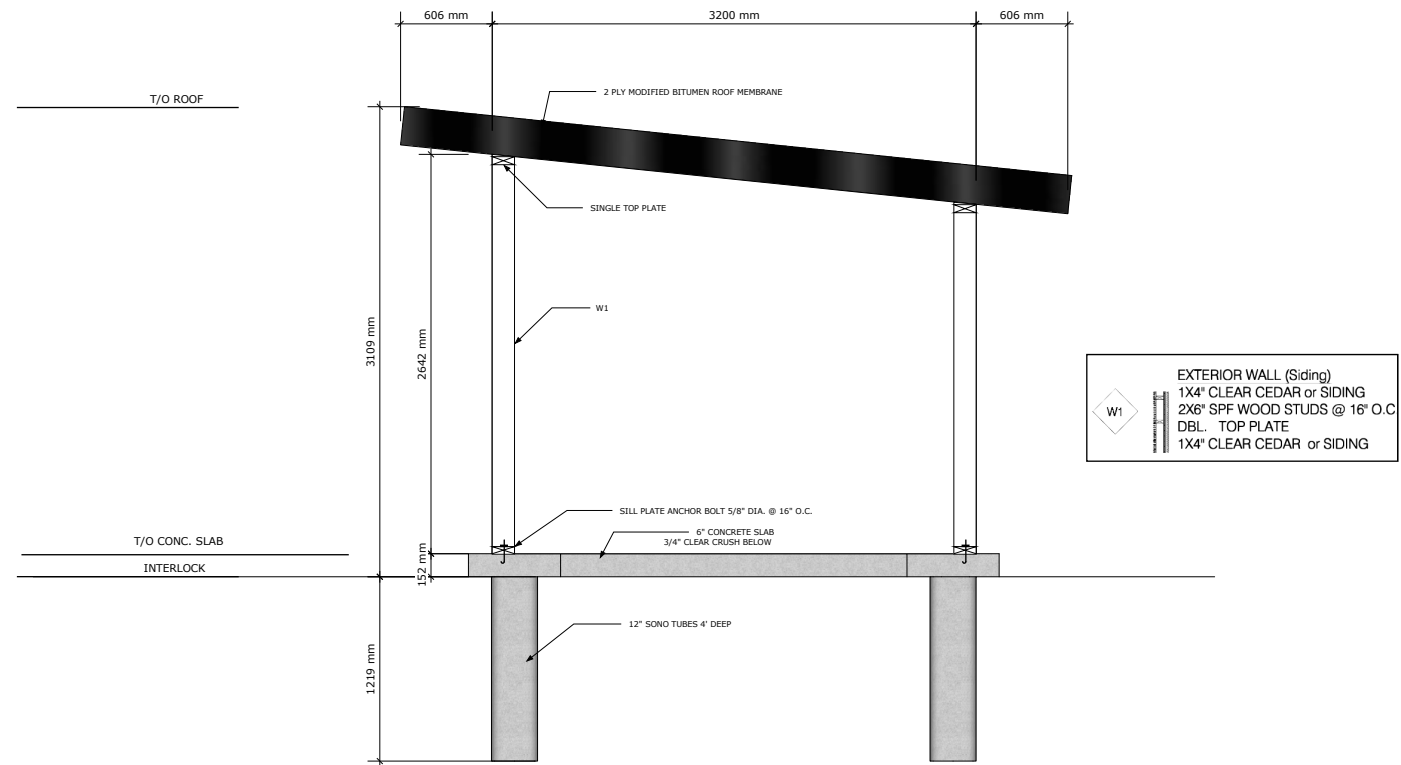

1 WALL DETAIL SOUTH ELEVATION
1:50

**SCHEDULE B:
COMMENTS FROM AGENCIES, BUILDING STANDARDS &
DEVELOPMENT PLANNING**

Internal Departments *Comments Received	Conditions Required		Nature of Comments
Building Standards (Zoning)	Yes <input type="checkbox"/>	No <input checked="" type="checkbox"/>	General Comments
Development Planning	Yes <input type="checkbox"/>	No <input checked="" type="checkbox"/>	Recommend Approval/No Conditions

External Agencies *Comments Received	Conditions Required		Nature of Comments *See Schedule B for full comments
Alectra	Yes <input type="checkbox"/>	No <input checked="" type="checkbox"/>	General Comments
TRCA	Yes <input type="checkbox"/>	No <input checked="" type="checkbox"/>	General Comments
Region of York	Yes <input type="checkbox"/>	No <input checked="" type="checkbox"/>	General Comments

To: Committee of Adjustment
From: Niloufar Youssefi, Building Standards Department
Date: April 13, 2026
Applicant: Square Design Group
Location: 83 Ayton Crescent
PLAN 65M2768 Lot 4
File No.(s): A029/26

Zoning Classification:

The subject lands are zoned R1B(EN) – First Density Residential Zone (Established Neighbourhood) and subject to the provisions of Exception 14.493 under Zoning By-law 001-2021, as amended.

#	Zoning By-law 001-2021	Variance requested
1	An accessory building or structure with a height of 2.8 m or greater shall be setback a minimum of 2.16 m to the rear lot line. [Section 4.1.2 1b and Bill 17]	To permit an accessory structure (Cabana) with a height of 2.8m or greater to be setback a minimum of 2.007 m to the rear lot line.
2	An accessory building or structure with a height of 2.8 m or greater shall be setback a minimum of 4.05 m to the exterior side lot line. [Section 4.1.2 1b and Bill 17]	To permit an accessory structure (Cabana) with a height of 2.8m or greater to be setback a minimum of 1.338 m to the exterior side lot line.
3	In any Residential Zone, the maximum height of an accessory building or structure shall be 3.0 m . [Section 4.1.4.1.]	To permit a maximum height of 3.11 m for an accessory structure (Cabana).
4	Eaves, eavestroughs, and gutters are permitted to encroach a maximum of 0.5 m into any required yard. [Section 4.13, Table 4-1]	To permit Eaves, eavestroughs, and gutters to encroach a maximum of 0.654 m into the minimum required exterior side yard.
5	Eaves, eavestroughs, and gutters are permitted to encroach a maximum of 0.5 m into any required yard. [Section 4.13, Table 4-1]	To permit Eaves, eavestroughs, and gutters to encroach a maximum of 0.61 m into the minimum required rear yard.
6	A retaining wall shall be setback an equal distance to the height of the highest portion of the retaining wall. [Section 4.13, Table 4-1]	To permit a retaining wall with a maximum height of 1.0 m to be setback a minimum of 0.457 m from the rear lot line.

Staff Comments:

Zoning By-law 001-2021	
1	The minimum setback provisions of zoning by-law 001-2021, as amended, have been adjusted according to Bill 17.

General Comments	
2	The applicant shall be advised that additional variances may be required upon review of detailed drawing for building permit/site plan approval.

Conditions of Approval:

If the committee finds merit in the application, the following conditions of approval are recommended.

* Comments are based on the review of documentation supplied with this application.

To: Christine Vigneault, Committee of Adjustment Secretary Treasurer
From: Nancy Tuckett, Director of Development and Parks Planning
Date: April 21, 2026
Name of Owner: Anthony Segreto and Georgia Maria Tsoromocos
Location: 83 Ayton Crescent
File No.(s): A029/26

Proposed Variance(s):

1. To permit an accessory structure (Cabana) with a height of 2.8m or greater to be setback a minimum of **2.007 m** to the rear lot line.
2. To permit an accessory structure (Cabana) with a height of 2.8m or greater to be setback a minimum of **1.338 m** to the exterior side lot line.
3. To permit a maximum height of **3.11 m** for an accessory structure (Cabana).
4. To permit eaves, eavestroughs, and gutters to encroach a maximum of **0.654 m** into the minimum required exterior side yard.
5. To permit eaves, eavestroughs, and gutters to encroach a maximum of **0.61 m** into the minimum required rear yard.
6. To permit a retaining wall with a maximum height of 1.0 m to be setback a minimum of **0.457 m** from the rear lot line.

By-Law 001-2021 Requirement(s):

1. An accessory building or structure with a height of 2.8 m or greater shall be setback a minimum of **2.16 m** to the rear lot line. [Section 4.1.2 1b and Bill 17]
2. An accessory building or structure with a height of 2.8 m or greater shall be setback a minimum of **4.05 m** to the exterior side lot line. [Section 4.1.2 1b and Bill 17]
3. In any Residential Zone, the maximum height of an accessory building or structure shall be **3.0 m**. [Section 4.1.4.1.]
4. Eaves, eavestroughs, and gutters are permitted to encroach a maximum of **0.5 m** into any required yard. [Section 4.13, Table 4-1]
5. Eaves, eavestroughs, and gutters are permitted to encroach a maximum of **0.5 m** into any required yard. [Section 4.13, Table 4-1]
6. A retaining wall shall be setback an equal distance to the height of the highest portion of the retaining wall. [Section 4.13, Table 4-1]

Official Plan:

Vaughan Official Plan ('VOP 2010'): "Low-Rise Residential"

Comments:

The Owner is seeking relief to permit an accessory structure (cabana) with the above noted variances.

The Development and Parks Planning Department has no objections to Variances 1 and 2 to permit a setback of 2.007 m to the rear lot line and 1.338 m to the exterior side lot line for the cabana. The lot has an irregular shape and the proposed minimum setback is the shortest distance between the cabana setback to exterior side lot line. The setback expands from 1.338 m to 1.743 m towards the rear of the property. The proposed setback maintains sufficient space for access and maintenance, and is not anticipated to have a negative impact on the public realm as the proposed cabana is modest, mostly unenclosed, and will be screened by existing vegetation in the exterior side yard. The proposed setback of 2.007 m to the rear lot line is a minor deviation from the requirement of 2.15 m and will maintain sufficient space for access and maintenance, and is not anticipated to have a negative impact on the adjacent property.

The Development and Parks Planning Department has no objection to Variance 3 to permit a maximum height of 3.11 m for the cabana. The proposed height of 3.11 m is a minor increase from the requirement of 3 m. The cabana has a modest mostly unenclosed design and there is existing vegetation along the rear and exterior lot line, the proposed height is not anticipated to have any negative visual impacts on the adjacent property or the public realm.

The Development and Parks Planning Department has no objections to Variances 4 and 5 to permit the eaves of the cabana to encroach 0.654 m into the exterior side yard and 0.61 m into the required rear yard. The proposed encroachments will maintain sufficient space for access and maintenance within the exterior side yard and rear yard and will not negatively impact adjacent properties or the public realm due to the modest design of the cabana and existing vegetation to provide for visual screening.

The Development and Parks Planning Department has no objections to Variance 6 to permit a retaining wall with a maximum height of 1.0 m to be setback a minimum of 0.457 m from the rear lot line. The retaining wall is measured at 1.0 m and is only partially above grade between the rear lot line and the retaining wall. The retaining wall is not anticipated to be perceivable from the adjacent rear lot. There is an existing wooden fence and vegetation along the rear lot line that provides for visual screening.

Development Engineering staff have reviewed the proposal and have issued an approved Grading Permit for the property. The approved grading plan demonstrates that adequate drainage provisions have been incorporated to ensure surface water runoff from the proposed structures does not negatively impact adjacent properties, as such Development Engineering has no concerns.

Accordingly, the Development and Parks Planning Department supports the requested variances and is of the opinion that the proposal is minor in nature, maintains the general intent and purpose of the Official Plan and Zoning By-law, and is desirable for the appropriate development of the land.

Recommendation:

The Development and Parks Planning Department recommends approval of the application.

Conditions of Approval:

If the Committee finds merit in the application, the following conditions of approval are recommended:

None.

Comments Prepared by:

Cordell Smith-Palmer, Planner 1
Janany Nagulan, Senior Planner

From: [Development Services](#)
To: [Committee of Adjustment Mailbox](#)
Subject: [External] RE: A029/26 - 83 AYTON CRESCENT - REQUEST FOR COMMENTS, CITY OF VAUGHAN
Date: Tuesday, March 17, 2026 3:19:08 PM

CAUTION! This is an external email. Verify the sender's email address and carefully examine any links or attachments before clicking. If you believe this may be a phishing email, please use the Phish Alert Button.

Good afternoon,

The Regional Municipality of York has completed its review of the above minor variance and has no comment.

Regards,

Gabrielle

Gabrielle Hurst MCIP, RPP

Associate Development Specialist, Development Services, Economic and Development Services Branch
Corporate Services Department

The Regional Municipality of York | 17250 Yonge Street | Newmarket, ON L3Y 8V3

O: 905-830-4444 ext. 71538 | developmentservices@york.ca |

Our Mission: **Working together to serve our thriving communities – today and tomorrow**

For more information check us out at www.york.ca/developmentservices

SCHEDULE C: PUBLIC & APPLICANT CORRESPONDENCE

None

SCHEDULE D: BACKGROUND

None