

ITEM: 6.4	REPORT SUMMARY MINOR VARIANCE APPLICATION FILE NUMBER A005/26
------------------	--

Report Date: April 24, 2026

**THIS REPORT CONTAINS COMMENTS FROM THE FOLLOWING
DEPARTMENTS & AGENCIES (SEE SCHEDULE B):**

Additional comments from departments and agencies received after the publication of the report will be made available on the City's [website](#).

Internal Departments <small>*Comments Received</small>	Conditions Required		Nature of Comments
Committee of Adjustment	Yes <input type="checkbox"/>	No <input checked="" type="checkbox"/>	General Comments
Building Standards (Zoning)	Yes <input type="checkbox"/>	No <input checked="" type="checkbox"/>	General Comments
Development Planning	Yes <input type="checkbox"/>	No <input type="checkbox"/>	Application Under Review
Development Engineering	Yes <input type="checkbox"/>	No <input checked="" type="checkbox"/>	General Comments
Development Finance	Yes <input type="checkbox"/>	No <input checked="" type="checkbox"/>	General Comments
By-law & Compliance	Yes <input type="checkbox"/>	No <input checked="" type="checkbox"/>	General Comments

External Agencies <small>*Comments Received</small>	Conditions Required		Nature of Comments <small>*See Schedule B for full comments</small>
TRCA	Yes <input checked="" type="checkbox"/>	No <input type="checkbox"/>	General Comments w/Conditions
Alectra	Yes <input type="checkbox"/>	No <input checked="" type="checkbox"/>	General Comments
Region of York	Yes <input type="checkbox"/>	No <input checked="" type="checkbox"/>	General Comments
YCDSB	Yes <input type="checkbox"/>	No <input checked="" type="checkbox"/>	General Comments

PUBLIC & APPLICANT CORRESPONDENCE (SEE SCHEDULE C)

All personal information collected because of this public meeting (including both written and oral submissions) is collected under the authority of the Municipal Act, the Municipal Freedom of Information and Protection of Privacy Act (MFIPPA), the Planning Act and all other relevant legislation, and will be used to assist in deciding on this matter. All personal information (as defined by MFIPPA), including (but not limited to) names, addresses, opinions and comments collected will become property of the City of Vaughan, will be made available for public disclosure (including being posted on the internet) and will be used to assist the Committee of Adjustment and staff to process this application.

Correspondence Type	Name	Address	Date Received <small>(mm/dd/yyyy)</small>	Summary
N/A				

BACKGROUND (SCHEDULE D, IF REQUIRED)

* Background Information contains historical development approvals considered to be related to this file.
This information should not be considered comprehensive.

Application No. (City File)	Application Description <small>(i.e. Minor Variance Application; Approved by COA / OLT)</small>
N/A	N/A

ADJOURNMENT HISTORY

* Previous hearing dates where this application was adjourned by the Committee and public notice issued.

Hearing Date	Reason for Adjournment <small>(to be obtained from NOD_ADJ)</small>
N/A	N/A

SCHEDULES

Schedule A	Drawings & Plans Submitted with the Application
Schedule B	Comments from Agencies, Building Standards & Development Planning
Schedule C (if required)	Public & Applicant Correspondence
Schedule D (if required)	Background



MINOR VARIANCE APPLICATION FILE NUMBER A005/26

CITY WARD #:	5
APPLICANT:	Robert Barron & Polyana Barron
AGENT:	Pool Craft
PROPERTY:	67 Wigston Place, Thornhill
ZONING DESIGNATION:	See below.
VAUGHAN OFFICIAL PLAN (2010) DESIGNATION:	Vaughan Official Plan ("VOP 2010"): "Low-Rise Residential"
RELATED DEVELOPMENT APPLICATIONS:	N/A
PURPOSE OF APPLICATION:	Relief from the Zoning By-law is being requested to permit the construction of a proposed cabana in the rear yard and reduced soft landscaping requirements in the front yard.

The following variances have been requested from the City's Zoning By-law:

The subject lands are zoned R1A(EN) – First Density Residential Zone (Established Neighbourhood) under Zoning By-law 001-2021, as amended.

#	Zoning By-law 001-2021	Variance requested
1	An accessory building or structure with a height of 2.8 m or greater shall be setback a minimum of 2.4 m to the rear lot line. [Section 4.1.2 1b]	To permit an accessory structure (Cabana) with a height of 2.8 m or greater to be setback a minimum of 0.6 m to the rear lot line.
2	An accessory building or structure with a height of 2.8 m or greater shall be setback a minimum of 2.4 m to the interior side lot line. [Section 4.1.2 1b]	To permit an accessory structure (Cabana) with a height of 2.8 m or greater to be setback a minimum of 2.05 m to the rear lot line.
3	A minimum distance of 0.6 m shall be required from any permitted encroachment to the nearest lot line. [Section 4.13.3.]	To permit a minimum distance of 0.36 m from the Cabana Eaves to the rear lot line.
4	Where lot frontage is 12.0 m or greater, the minimum landscape shall be 50% , of which 60% shall be soft landscape for a yard in which a driveway is located. [Section 4.19.1.2a]	To permit the minimum landscape to be 35% , of which 60% shall be soft landscape for a yard in which a driveway is located.

HEARING INFORMATION

DATE OF MEETING: Thursday, April 30, 2026

TIME: 6:00 p.m.

MEETING LOCATION: Vaughan City Hall, Woodbridge Room (2nd Floor), 2141 Major Mackenzie Drive

LIVE STREAM LINK: Vaughan.ca/LiveCouncil

PUBLIC PARTICIPATION

If you would like to speak to the Committee of Adjustment at the meeting, either remotely or in person, please complete the [Request to Speak Form](#) and submit to cofa@vaughan.ca

If you would like to submit written comments, please quote file number above and submit by mail or email to:

Email: cofa@vaughan.ca

Mail: City of Vaughan, Office of the City Clerk, Committee of Adjustment, 2141 Major Mackenzie Drive, Vaughan, ON, L6A 1T1

To speak electronically, pre-registration is required by completing the [Request to Speak Form](#) on-line and submitting it to cofa@vaughan.ca no later than NOON on the last business day before the meeting.

HEARING INFORMATION

THE DEADLINE TO REGISTER TO SPEAK ELECTRONICALLY OR SUBMIT WRITTEN COMMENTS ON THE ABOVE NOTED FILE(S) IS NOON ON THE LAST BUSINESS DAY BEFORE THE MEETING.

INTRODUCTION

Staff and Agencies act as advisory bodies to the Committee of Adjustment. The comments contained in this report are presented as recommendations to the Committee.

Section 45(1) of the Planning Act sets the criteria for authorizing minor variances to the City of Vaughan's Zoning By-law. Accordingly, review of the application may consider the following:

- That the general intent and purpose of the by-law will be maintained.
- That the general intent and purpose of the official plan will be maintained.
- That the requested variance(s) is/are acceptable for the appropriate development of the subject lands.
- That the requested variance(s) is/are minor in nature.

Public written and oral submissions relating to this application are taken into consideration by the Committee of Adjustment as part of its deliberations and final decision on this matter.

COMMITTEE OF ADJUSTMENT

Date Public Notice Mailed:	April 16, 2026
Date Applicant Confirmed Posting of Sign:	April 17, 2026
Applicant Justification for Variances: <small>*As provided in Application Form</small>	Required setback is not ideal for property size
Was a Zoning Review Waiver (ZRW) Form submitted by Applicant: <small>*ZRW Form may be used by applicant in instances where a revised submission is made, and zoning staff do not have an opportunity to review and confirm variances prior to the issuance of public notice.</small>	Yes <input type="checkbox"/> No <input checked="" type="checkbox"/>
COMMENTS:	
None	
Committee of Adjustment Recommended Conditions of Approval:	None

BUILDING STANDARDS (ZONING)

**See Schedule B for Building Standards (Zoning) Comments	
Building Standards Recommended Conditions of Approval:	None

DEVELOPMENT PLANNING

**See Schedule B for Development Planning Comments.	
Development Planning Recommended Conditions of Approval:	TBD

DEVELOPMENT ENGINEERING

[Link to Grading Permit](#) [Link to Pool Permit](#) [Link to Curb Curt Permit](#) [Link Culvert Installation](#)

Development Engineering has reviewed the proposed cabana, swimming pool, and deck associated with Minor Variance Application A005/26 and offers the following comments:

- The Owner/Applicant shall ensure that positive surface drainage is maintained across the subject property at all times, and that the proposed construction does not create, redirect, or exacerbate drainage impacts on adjacent private or public lands.
- The property shall be graded such that surface water runoff from the cabana, swimming pool, and deck does not adversely impact neighbouring properties, the municipal right-of-way, or any downstream drainage systems.
- Grading and Pool Permits for the subject property have already been issued and approved. All construction shall be carried out in strict conformance with the approved grading plan, pool permit, and the City of Vaughan's Engineering Standards. Any deviation from the approved drawings will require re-submission and re-approval prior to implementation.

The Development Engineering Department has no objection to Minor Variance Application A005/26.

DEVELOPMENT ENGINEERING

[Link to Grading Permit](#)
 [Link to Pool Permit](#)
 [Link to Curb Curt Permit](#)
 [Link Culvert Installation](#)

Development Engineering Recommended Conditions of Approval:	None
--	------

PARKS, FORESTRY & HORTICULTURE (PFH)

Recommended condition of approval listed below.	
PFH Recommended Conditions of Approval:	The Applicant/owner shall obtain a “Private Property Tree Removal & Protection Permit - Construction or Infill” through the forestry division prior to any construction works on the subject property.

DEVELOPMENT FINANCE

No comment no concerns	
Development Finance Recommended Conditions of Approval:	None

BY-LAW AND COMPLIANCE, LICENSING AND PERMIT SERVICES

Bylaw has an active file for allegedly trees being removed in the backyard.	
BCLPS Recommended Conditions of Approval:	None

BUILDING INSPECTION (SEPTIC)

No comments received to date.	
Building Inspection Recommended Conditions of Approval:	None

FIRE DEPARTMENT

No comments received to date.	
Fire Department Recommended Conditions of Approval:	None

RECOMMENDED CONDITIONS OF APPROVAL SUMMARY

Should the Committee find it appropriate to approve this application in accordance with request and the sketch submitted with the application, as required by Ontario Regulation 200/96, the following conditions have been recommended:

#	DEPARTMENT / AGENCY	CONDITION
1	Development Planning Alesia.lamaj@vaughan.ca	TBD
2	Parks, Forestry and Horticulture Operations kari.sthyrhansen@vaughan.ca	The Applicant/owner shall obtain a “Private Property Tree Removal & Protection Permit - Construction or Infill” through the forestry division prior to any construction works on the subject property.
3	TRCA yorkplan@trca.ca	The applicant submits the variance application review fee of \$695 payable to TRCA.

All conditions of approval, unless otherwise stated, are considered to be incorporated into the approval “if required”. If a condition is no longer required after an approval is final and binding, the condition may be waived by the respective department or agency requesting conditional approval. A condition cannot be waived without written consent from the respective department or agency.

IMPORTANT INFORMATION

CONDITIONS: It is the responsibility of the owner/applicant and/or authorized agent to obtain and provide a clearance letter from respective department and/or agency (**see condition chart above for contact**). This letter must be provided to the Secretary-Treasurer to be finalized. All conditions must be cleared prior to the issuance of a Building Permit.

IMPORTANT INFORMATION

APPROVALS: Making any changes to your proposal after a decision has been made may impact the validity of the Committee's decision.

An approval obtained from the Committee of Adjustment, where applicable, is tied to the building envelope shown on the plans and drawings submitted with the application and subject to the variance approval.

A building envelope is defined by the setbacks of the buildings and/or structures shown on the plans and drawings submitted with the application, as required by Ontario Regulation 200/96. Future development outside of an approved building envelope, where a minor variance was obtained, must comply with the provisions of the City's Zoning By-law.

Elevation drawings are provided to reflect the style of roof (i.e. flat, mansard, gable etc.) to which a building height variance has been applied. Where a height variance is approved, building height is applied to the style of roof (as defined in the City's Zoning By-law) shown on the elevation plans submitted with the application.

Architectural design features that are not regulated by the City's Zoning By-law are not to be considered part of an approval unless specified in the Committee's decision.

DEVELOPMENT CHARGES: That the payment of the Regional Development Charge, if required, is payable to the City of Vaughan before issuance of a building permit in accordance with the Development Charges Act and the Regional Development Charges By-law in effect at the time of payment.

That the payment of the City Development Charge, if required, is payable to the City of Vaughan before issuance of a building permit in accordance with the Development Charges Act and the City's Development Charges By-law in effect at the time of payment.

That the payment of the Education Development Charge if required, is payable to the City of Vaughan before issuance of a building permit in accordance with the Development Charges Act and the Boards of Education By-laws in effect at the time of payment

That the payment of Special Area Development charge, if required, is payable to the City of Vaughan before issuance of a building permit in accordance with the Development Charges Act and The City's Development Charge By-law in effect at the time of Building permit issuance to the satisfaction of the Reserves/Capital Department.

NOTICE OF DECISION: If you wish to be notified of the decision in respect to this application or a related Ontario Land Tribunal (OLT) hearing you must complete a Request for Decision form and submit to the Secretary Treasurer (ask staff for details). In the absence of a written request to be notified of the Committee's decision you will **not** receive notice.

SCHEDULE A: DRAWINGS & PLANS

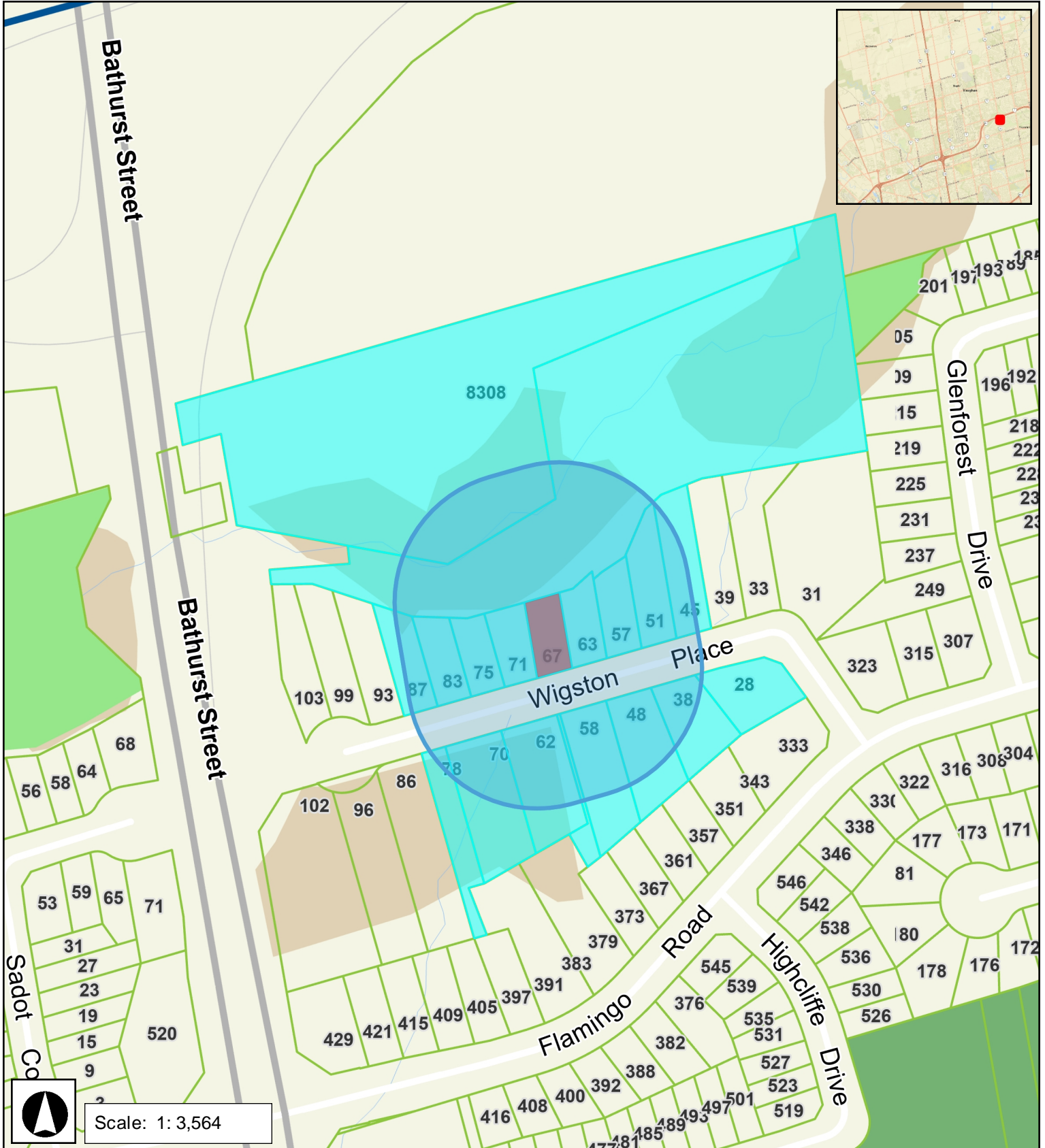

LOT INFO

LOT: 689.24m²
 HOUSE: 234.38m²
 REAR YARD AREA: 213.12m²
 REAR YARD SOFTSCAPE: 56.21m²
 REAR YARD HARDSCAPE: 156.91m²
 FRONT YARD AREA: 171.3m²
 FRONT YARD SOFTSCAPE: 58.7m²
 FRONT YARD HARDSCAPE: 4.2m²
 DRIVEWAY: 108.4m²

SOFTSCAPE
 HARDSCAPE

DRAWING LIST

SHEET INDEX	
SHEET #	SHEET NAME
A1.01	Site Plan
A2.01	Slab, Main, & Roof Plans
A3.01	Elevations
A4.01	Cabana Section & Detail
A5.01	Deck Plan & Sections



35%
#4

2.05m
#2

0.36m
#3

0.6m
#1

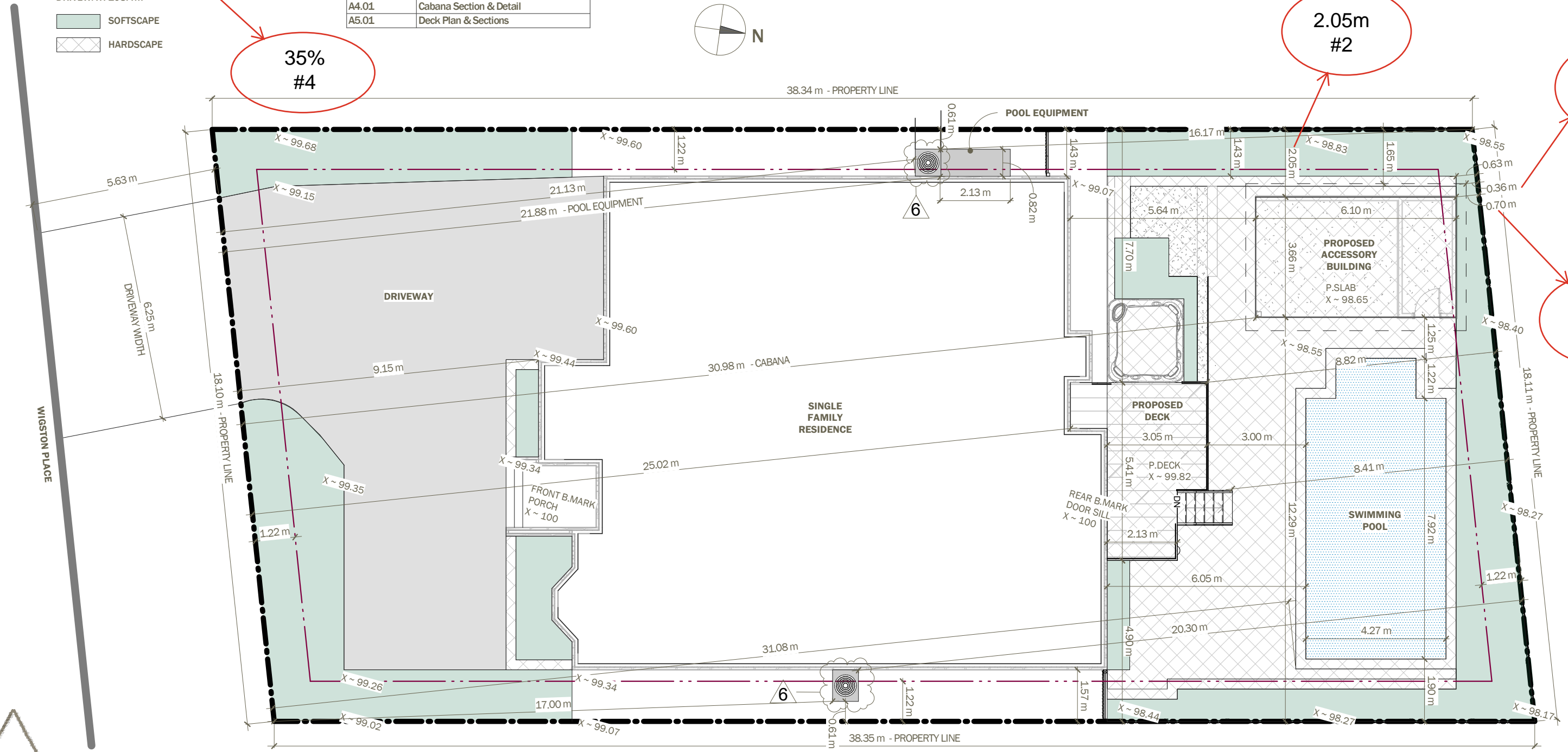

THE UNDERSIGNED HAS REVIEWED & TAKES RESPONSIBILITY FOR THIS DESIGN, & HAS THE QUALIFICATIONS & MEETS THE REQUIREMENTS SET OUT IN THE ONTARIO BUILDING CODE TO DESIGN THE WORK SHOWN ON THE ATTACHED DOCUMENTS

QUALIFICATION INFORMATION REQUIRED UNLESS DESIGN IS EXEMPT UNDER DIV. C - 3.2.5.1 OF THE BUILDING CODE

NAME **DANA EVANS** *D. Evans* BCIN **100332**

REGISTRATION INFORMATION REQUIRED UNLESS DESIGN IS EXEMPT UNDER DIV. C - 3.2.4.1 OF THE BUILDING CODE

FIRM NAME **EVANS-DESIGN** BCIN **204909**

Revisions

NO	DESCRIPTION	DATE
0	Minor Variance Application	2025-12-01
1	Minor Variance Rev 1	2026-01-27
2	Minor Variance Rev 2	2026-02-02
3	Minor Variance Rev 3	2026-02-10
4	BP Rev 4	2026-02-27
5	BP Rev 5	2026-03-20
6	MV Rev 6	2026-04-13

Project Name **Cabana**

Project Address **67 Wigston Place, Vaughan**

Current revision Date **2026-04-13**

Project No. **25-039**

Site Plan **A1.01**

NOTE BLOCK	
NOTE #	DESCRIPTION
C-B1	CABANA BEAM 3-2x10" w/ LPC6 & LCE4 SIMPSON CONNECTION
C-L1	CABANA LINTEL 2-2x6"
C-P1	CABANA POST 6x6"
C-P2	CABANA POST 3-2x4"
C-PB	CABANA POST BASE CB66
C-RJ	CABANA ROOF JOISTS - 2x10
D-B1	DECK BEAM - 2-2x8" PT w/ LPC6 & LCE4 SIMPSON CONNECTION
D-J1	DECK JOISTS 2x10" - PT w/ H1AZ TIE JOIST TO LEDGER CONNECTION
D-J2	DECK JOISTS 2x8" - PT w/ H1AZ TIE JOIST TO LEDGER CONNECTION
D-P1	DECK POST - 6x6" PT ON 12" CONCRETE PIER
EX-L	DECK EXISTING DECK LEDGER
L1	DECK LEDGER BELOW OR FUSHMOUNT

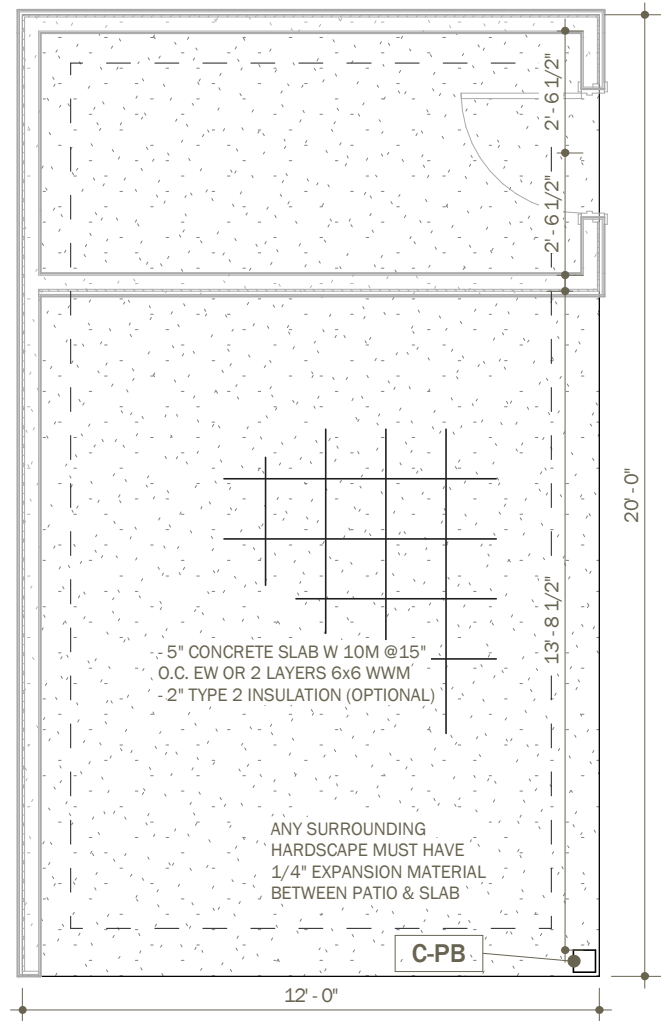

1 SLAB
1/4" = 1'-0"

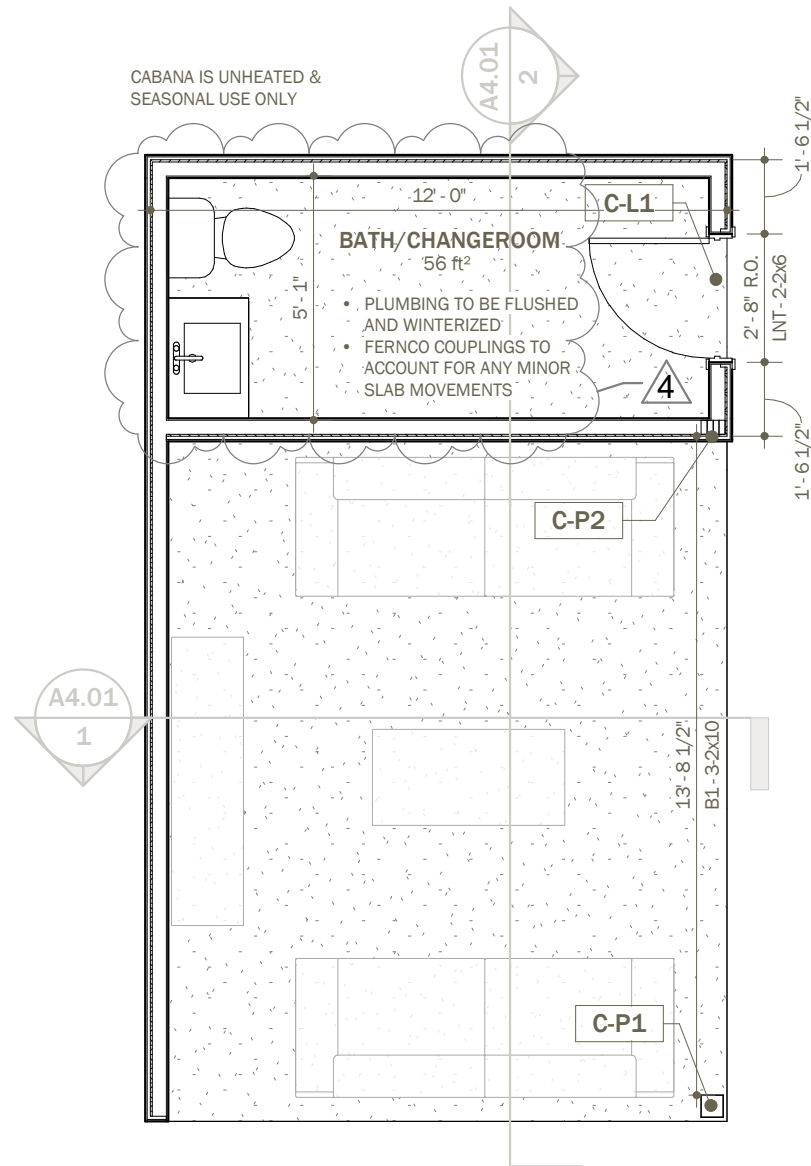

2 T/O SLAB
1/4" = 1'-0"

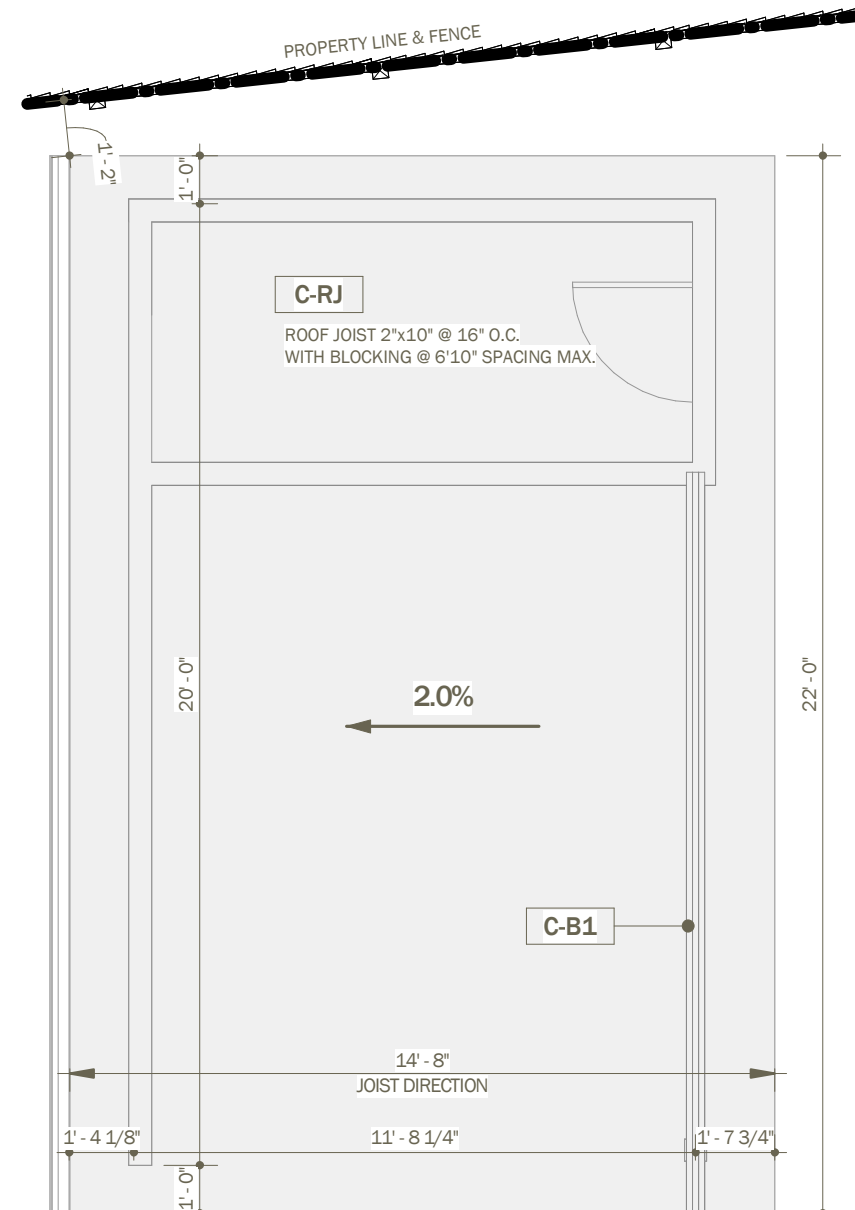

3 CABANA ROOF
1/4" = 1'-0"



THE UNDERSIGNED HAS REVIEWED & TAKES RESPONSIBILITY FOR THIS DESIGN, & HAS THE QUALIFICATIONS & MEETS THE REQUIREMENTS SET OUT IN THE ONTARIO BUILDING CODE TO DESIGN THE WORK SHOWN ON THE ATTACHED DOCUMENTS

QUALIFICATION INFORMATION REQUIRED UNLESS DESIGN IS EXEMPT UNDER DIV. C - 3.2.5.1 OF THE BUILDING CODE

NAME **DANA EVANS** *D. Evans* BCIN **100332**

REGISTRATION INFORMATION REQUIRED UNLESS DESIGN IS EXEMPT UNDER DIV. C - 3.2.4.1 OF THE BUILDING CODE

FIRM NAME **EVANS-DESIGN** BCIN **204909**

Revisions		
0	Minor Variance Application	2025-12-01
1	Minor Variance Rev 1	2026-01-27
4	Minor Variance Rev 4	2026-02-27

Project Name **Cabana**

Project Address **67 Wigston Place, Vaughan**

Current revision Date **2026-02-27**

Project No. **25-039**

Slab, Main, & Roof Plans

A2.01

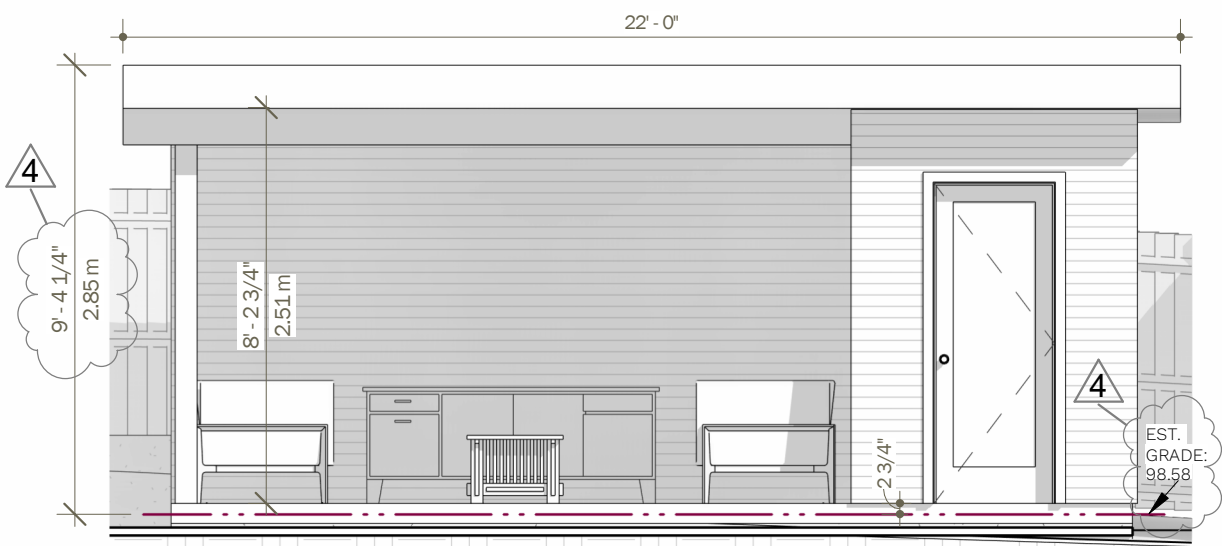

1 East
1/4" = 1'-0"

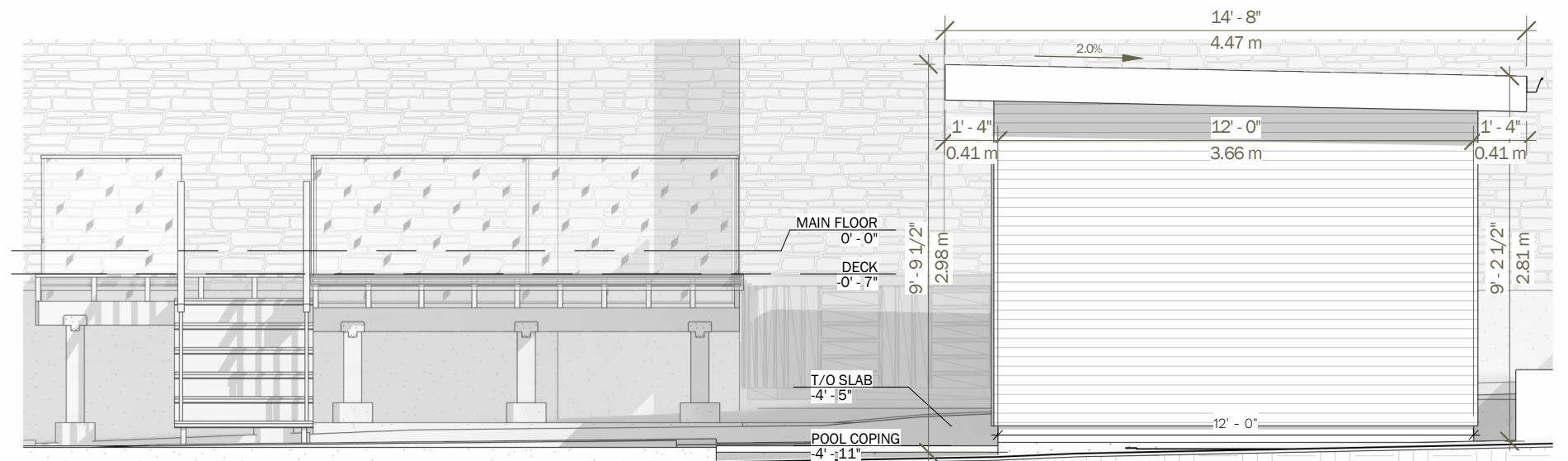

2 North (Deck & Cabana)
1/4" = 1'-0"

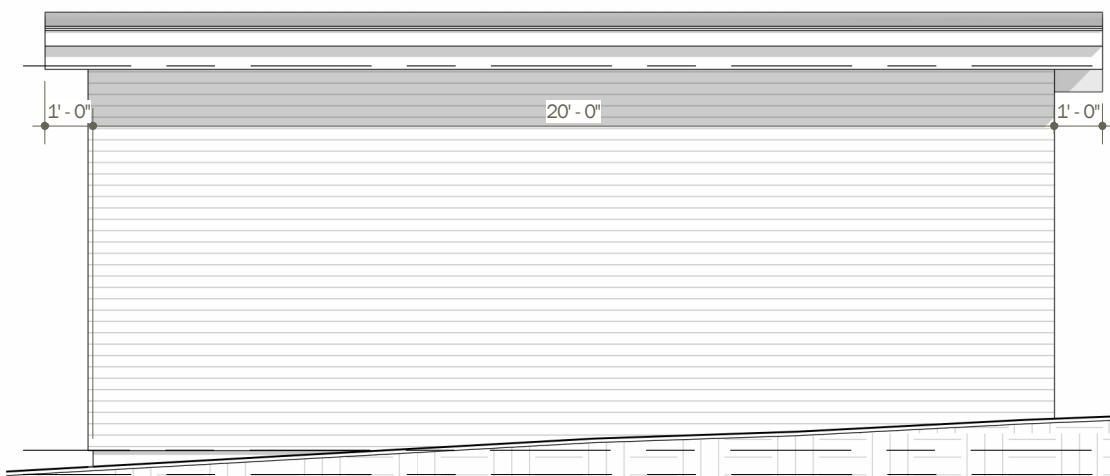

3 West (Deck & Cabana)
1/4" = 1'-0"

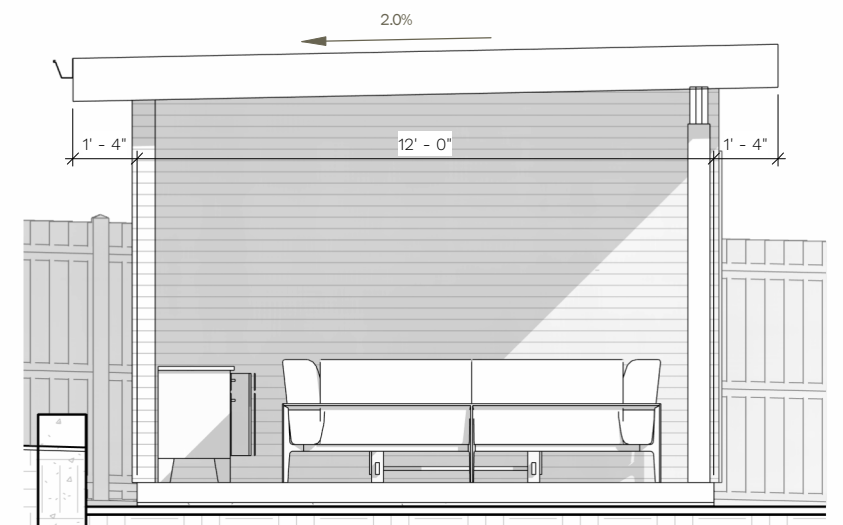
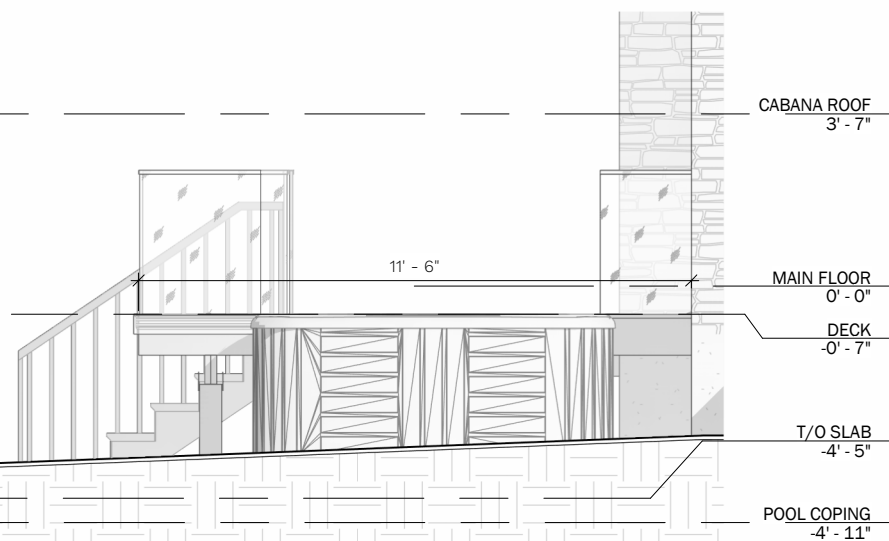

4 South (Cabana)
1/4" = 1'-0"



THE UNDERSIGNED HAS REVIEWED & TAKES RESPONSIBILITY FOR THIS DESIGN, & HAS THE QUALIFICATIONS & MEETS THE REQUIREMENTS SET OUT IN THE ONTARIO BUILDING CODE TO DESIGN THE WORK SHOWN ON THE ATTACHED DOCUMENTS

QUALIFICATION INFORMATION REQUIRED UNLESS DESIGN IS EXEMPT UNDER DIV. C - 3.2.5.1 OF THE BUILDING CODE

NAME **DANA EVANS** *D. Evans* BCIN **100332**

REGISTRATION INFORMATION REQUIRED UNLESS DESIGN IS EXEMPT UNDER DIV. C - 3.2.4.1 OF THE BUILDING CODE

FIRM NAME **EVANS-DESIGN** BCIN **204909**

Revisions

Revision No.	Description	Date
0	Minor Variance Application	2025-12-01
2	Minor Variance Rev 2	2026-02-02
3	Minor Variance Rev 3	2026-02-10
4	Minor Variance Rev 4	2026-02-27

Project Name

Cabana

Project Address

**67 Wigston Place,
Vaughan**

Current revision Date

2026-02-27

Project No.

25-039

Elevations

A3.01

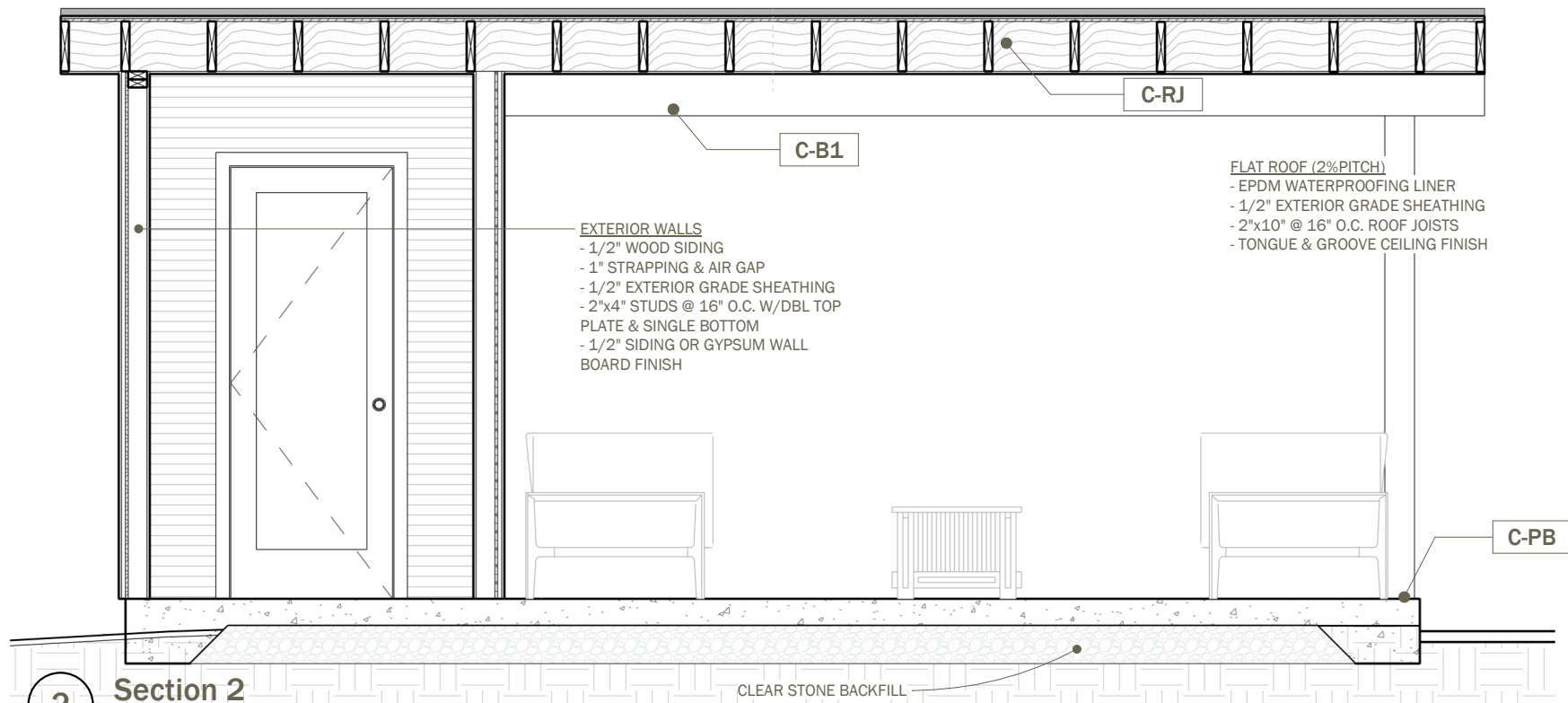
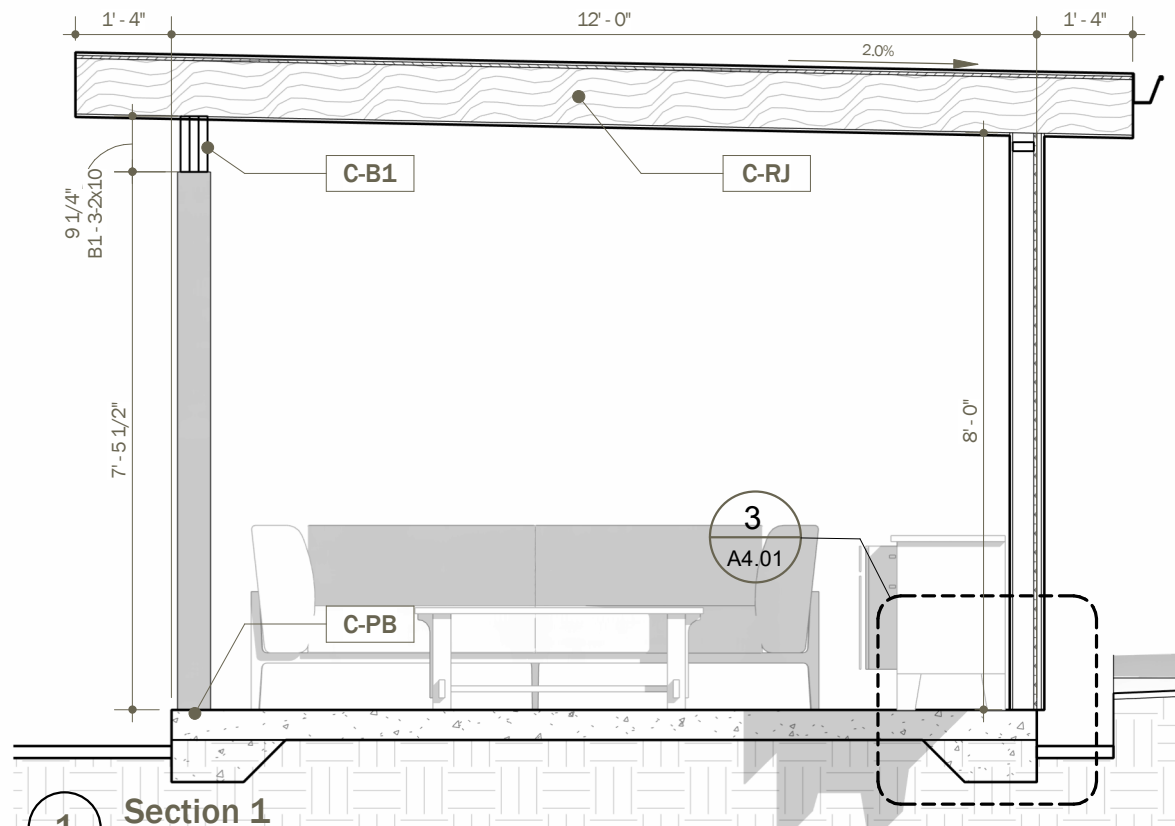

NOTE BLOCK

NOTE #	DESCRIPTION
C-B1	CABANA BEAM 3-2x10" w/ LPC6 & LCE4 SIMPSON CONNECTION
C-L1	CABANA LINTEL 2-2x6"
C-P1	CABANA POST 6x6"
C-P2	CABANA POST 3-2x4"
C-PB	CABANA POST BASE CB66
C-RJ	CABANA ROOF JOISTS - 2x10
D-B1	DECK BEAM - 2-2x8" PT w/ LPC6 & LCE4 SIMPSON CONNECTION
D-J1	DECK JOISTS 2x10" - PT w/ H1AZ TIE JOIST TO LEDGER CONNECTION
D-J2	DECK JOISTS 2x8" - PT w/ H1AZ TIE JOIST TO LEDGER CONNECTION
D-P1	DECK POST - 6x6" PT ON 12" CONCRETE PIER
EX-L	DECK EXISTING DECK LEDGER
L1	DECK LEDGER BELOW OR FUSHMOUNT

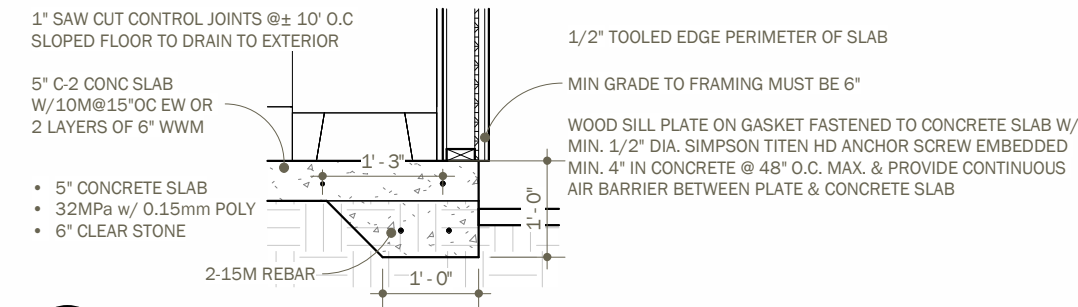

THE UNDERSIGNED HAS REVIEWED & TAKES RESPONSIBILITY FOR THIS DESIGN, & HAS THE QUALIFICATIONS & MEETS THE REQUIREMENTS SET OUT IN THE ONTARIO BUILDING CODE TO DESIGN THE WORK SHOWN ON THE ATTACHED DOCUMENTS

QUALIFICATION INFORMATION REQUIRED UNLESS DESIGN IS EXEMPT UNDER DIV. C - 3.2.5.1 OF THE BUILDING CODE

NAME **DANA EVANS** *D. Evans* BCIN **100332**

REGISTRATION INFORMATION REQUIRED UNLESS DESIGN IS EXEMPT UNDER DIV. C - 3.2.4.1 OF THE BUILDING CODE

FIRM NAME **EVANS-DESIGN** BCIN **204909**

Revisions

0	Minor Variance Application	2025-12-01
1	Minor Variance Rev 1	2026-01-27

Project Name **Cabana**

Project Address **67 Wigston Place, Vaughan**

Current revision Date **2026-01-27**

Project No. **25-039**

Cabana Section & Detail

A4.01

NOTE BLOCK

NOTE #	DESCRIPTION
C-B1	CABANA BEAM 3-2x10" w/ LPC6 & LCE4 SIMPSON CONNECTION
C-L1	CABANA LINTEL 2-2x6"
C-P1	CABANA POST 6x6"
C-P2	CABANA POST 3-2x4"
C-PB	CABANA POST BASE CB66
C-RJ	CABANA ROOF JOISTS - 2x10
D-B1	DECK BEAM - 2-2x8" PT w/ LPC6 & LCE4 SIMPSON CONNECTION
D-J1	DECK JOISTS 2x10" - PT w/ H1AZ TIE JOIST TO LEDGER CONNECTION
D-J2	DECK JOISTS 2x8" - PT w/ H1AZ TIE JOIST TO LEDGER CONNECTION
D-P1	DECK POST - 6x6" PT ON 12" CONCRETE PIER
EX-L	DECK EXISTING DECK LEDGER
L1	DECK LEDGER BELOW OR FUSHMOUNT

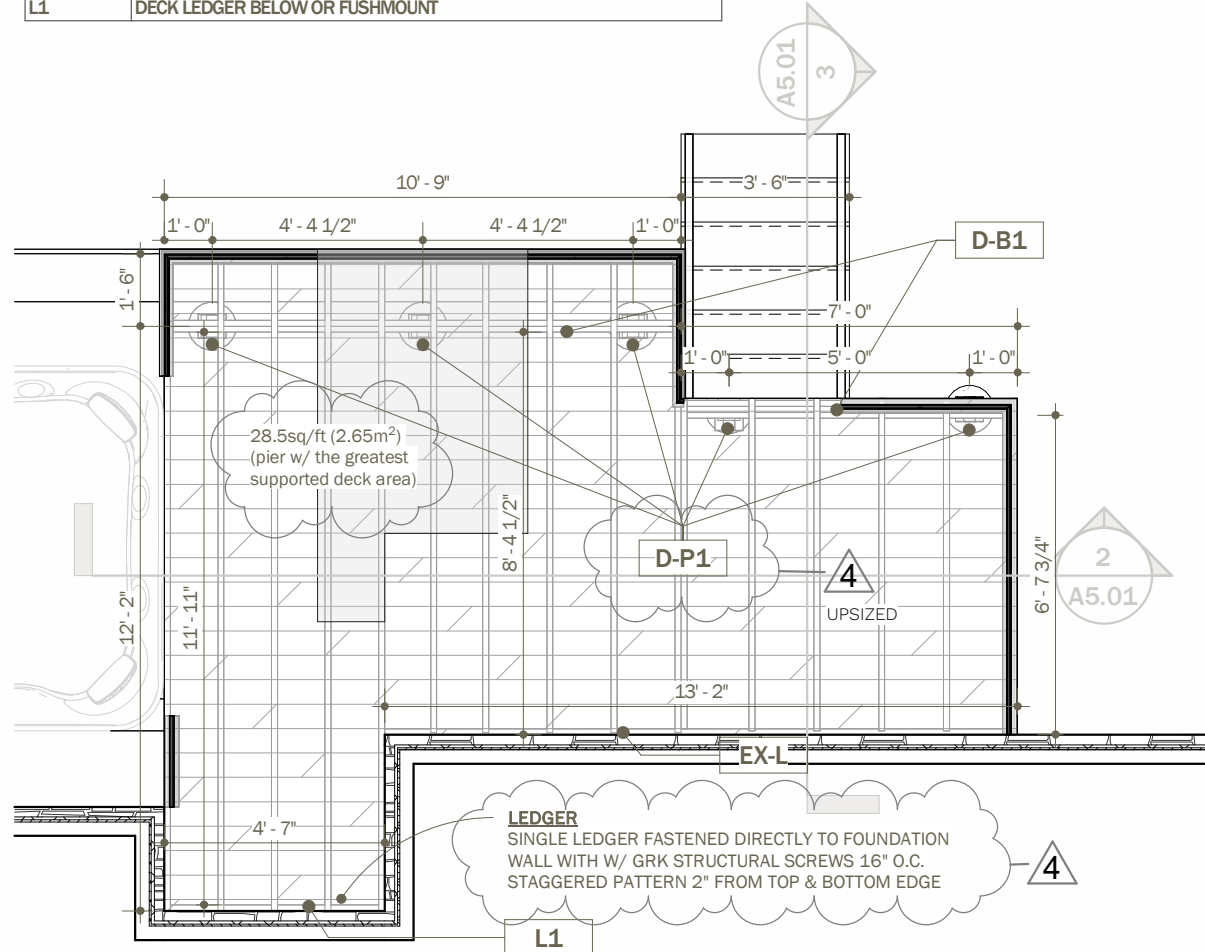

1 DECK
SCALE: 1/4" = 1'-0"

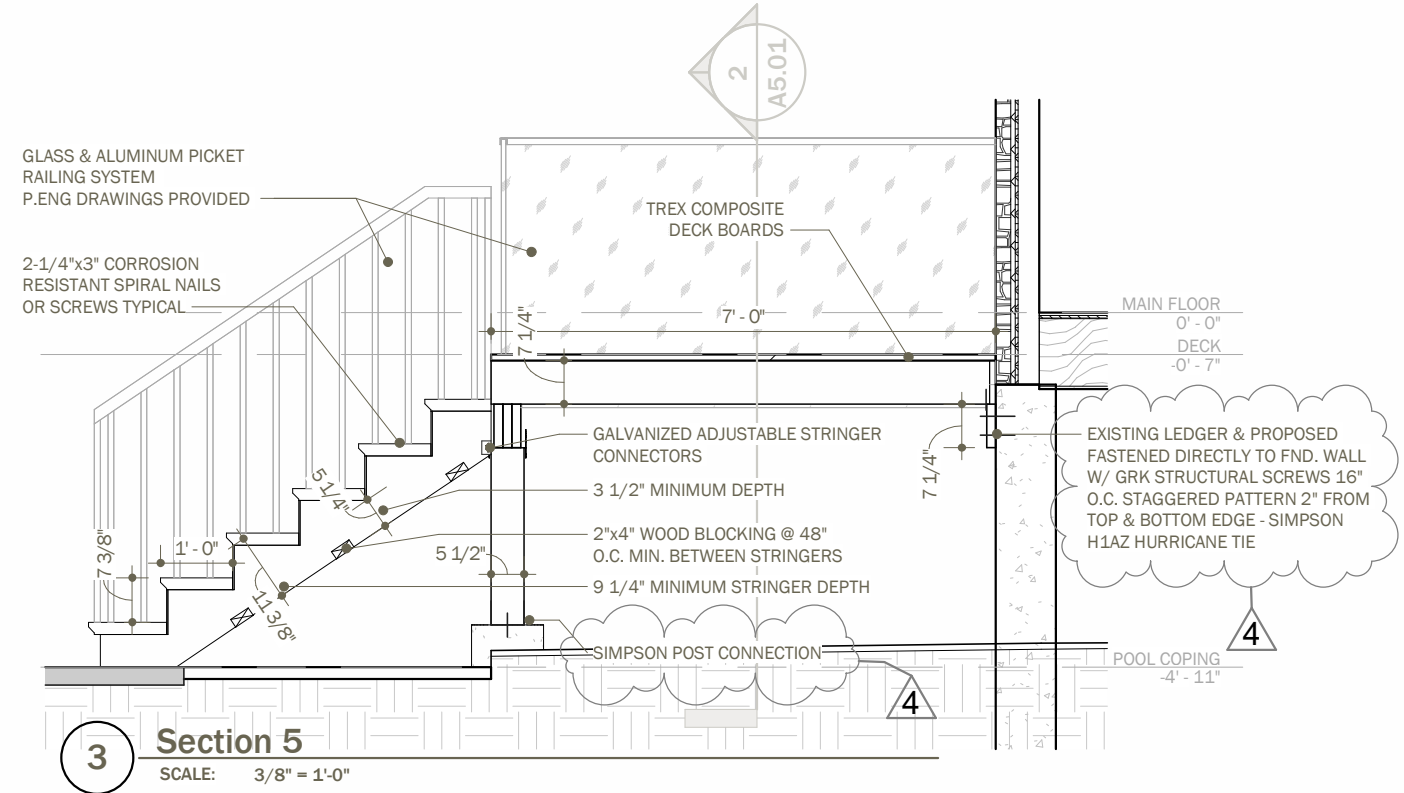

3 Section 5
SCALE: 3/8" = 1'-0"

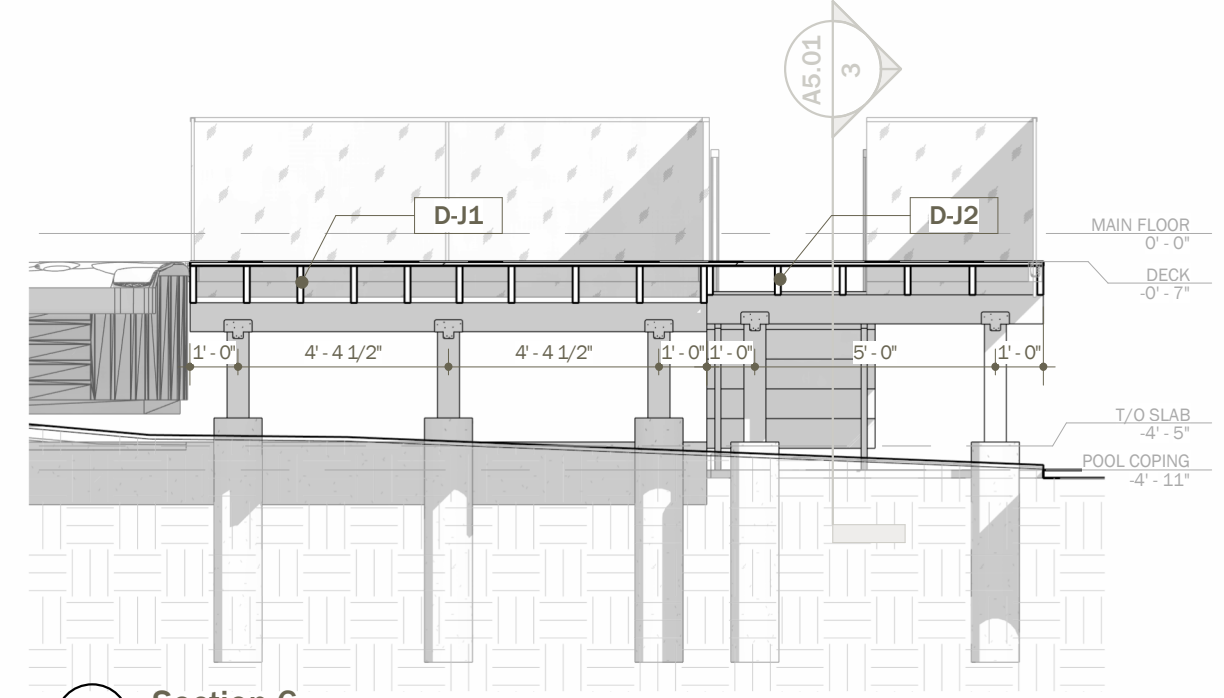

2 Section 6
SCALE: 1/4" = 1'-0"



THE UNDERSIGNED HAS REVIEWED & TAKES RESPONSIBILITY FOR THIS DESIGN, & HAS THE QUALIFICATIONS & MEETS THE REQUIREMENTS SET OUT IN THE ONTARIO BUILDING CODE TO DESIGN THE WORK SHOWN ON THE ATTACHED DOCUMENTS

QUALIFICATION INFORMATION REQUIRED UNLESS DESIGN IS EXEMPT UNDER DIV. C - 3.2.5.1 OF THE BUILDING CODE

NAME **DANA EVANS** *D. Evans* BCIN **100332**

REGISTRATION INFORMATION REQUIRED UNLESS DESIGN IS EXEMPT UNDER DIV. C - 3.2.4.1 OF THE BUILDING CODE

FIRM NAME **EVANS-DESIGN** BCIN **204909**

Revisions

Rev	Description	Date
0	Minor Variance Application	2025-12-01
1	Minor Variance Rev 1	2026-01-27
4	Minor Variance Rev 4	2026-02-27

Project Name **Cabana**

Project Address **67 Wigston Place, Vaughan**

Current revision Date **2026-02-27**

Project No. **25-039**

Deck Plan & Sections

A5.01

**SCHEDULE B:
COMMENTS FROM AGENCIES, BUILDING STANDARDS &
DEVELOPMENT PLANNING**

Internal Departments <small>*Comments Received</small>	Conditions Required		Nature of Comments
Building Standards (Zoning)	Yes <input type="checkbox"/>	No <input checked="" type="checkbox"/>	General Comments
Development Planning	Yes <input type="checkbox"/>	No <input type="checkbox"/>	Application Under Review

External Agencies <small>*Comments Received</small>	Conditions Required		Nature of Comments <small>*See Schedule B for full comments</small>
TRCA	Yes <input checked="" type="checkbox"/>	No <input type="checkbox"/>	General Comments w/Conditions
Alectra	Yes <input type="checkbox"/>	No <input checked="" type="checkbox"/>	General Comments
Region of York	Yes <input type="checkbox"/>	No <input checked="" type="checkbox"/>	General Comments
YCDSB	Yes <input type="checkbox"/>	No <input checked="" type="checkbox"/>	General Comments

Date: March 31st 2026

Attention: Sarah Scauzillo

RE: Request for Comments

File No.: A005-26

Related Files:

Applicant Pool Craft

Location 67 Wigston Place

COMMENTS:

- We have reviewed the proposed Variance Application and have no comments or objections to its approval.
- We have reviewed the proposed Variance Application and have no objections to its approval, subject to the following comments (attached below).
- We have reviewed the proposed Variance Application and have the following concerns (attached below).

Alectra Utilities (formerly PowerStream) has received and reviewed the proposed Variance Application. This review, however, does not imply any approval of the project or plan.

All proposed billboards, signs, and other structures associated with the project or plan must maintain minimum clearances to the existing overhead or underground electrical distribution system as specified by the applicable standards, codes and acts referenced.

In the event that construction commences, and the clearance between any component of the work/structure and the adjacent existing overhead and underground electrical distribution system violates the Occupational Health and Safety Act, the customer will be responsible for 100% of the costs associated with Alectra making the work area safe. All construction work will be required to stop until the safe limits of approach can be established.

In the event construction is completed, and the clearance between the constructed structure and the adjacent existing overhead and underground electrical distribution system violates the any of applicable standards, acts or codes referenced, the customer will be responsible for 100% of Alectra’s cost for any relocation work.

References:

- Ontario Electrical Safety Code, latest edition (Clearance of Conductors from Buildings)
- Ontario Health and Safety Act, latest edition (Construction Protection)
- Ontario Building Code, latest edition (Clearance to Buildings)
- PowerStream(Construction Standard 03-1, 03-4, 03-9), attached
- Canadian Standards Association, latest edition (Basic Clearances)

If more information is required, please contact either of the following:

ALECTRA UTILITIES CONTACT INFORMATION		
	EAST (WEST OF KEELE)	EAST (EAST OF KEELE)
Municipality:	Alliston, Aurora, Barrie, Beeton, Bradford West Gwillimbury, Penetanguishene, Thornton, Tottenham, Vaughan (West of Keele)	Markham, Richmond Hill, Vaughan (East of Keele)
Contact Name:	Azadeh Johardar	Randy Mustachi
Title:	Supervisor	Supervisor
Office Address:	161 Cityview Boulevard, Vaughan, ON, L4H 0A9	161 Cityview Boulevard, Vaughan, ON, L4H 0A9
Phone:	416.230.3239	416.902.5162
Email:	Azadeh.Johardar@Alectrautilities.com	Randy.Mustachi@AlectraUtilities.com

LOCATION OF WIRES, CABLES OR CONDUCTORS	SYSTEM VOLTAGE			
	SPAN GUYS AND COMMUNICATIONS WIRES	UP TO 600V AND NEUTRAL	4.16/2.4kV TO 27.6/16kV (SEE NOTE 1)	44kV
	MINIMUM VERTICAL CLEARANCES (SEE NOTE 2)			
OVER OR ALONGSIDE ROADS, DRIVEWAYS OR LANDS ACCESSIBLE TO VEHICLES	442cm	442cm	480cm	520cm
OVER GROUND ACCESSIBLE TO PEDESTRIANS AND BICYCLES ONLY	250cm	310cm	340cm	370cm
ABOVE TOP OF RAIL AT RAILWAY CROSSINGS	730cm	730cm	760cm	810cm

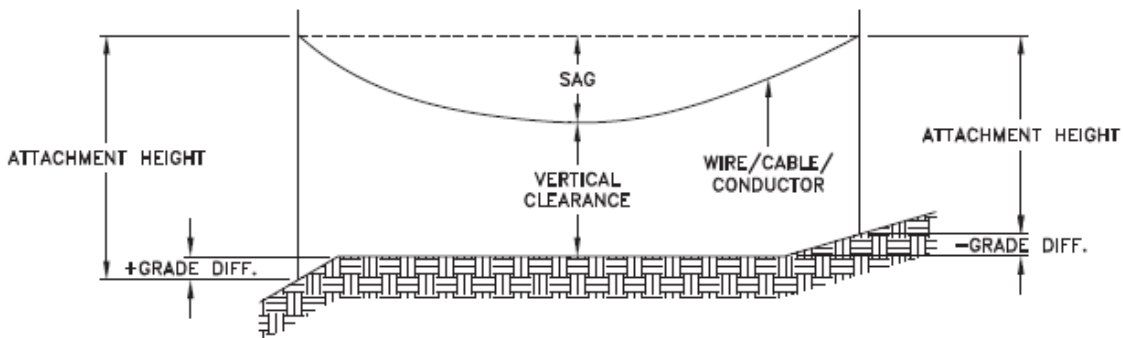

MINIMUM ATTACHMENT HEIGHT = MAXIMUM SAG
 + MINIMUM VERTICAL CLEARANCE (FROM ABOVE TABLE)
 ± GRADE DIFFERENCE
 + 0.3m (VEHICLE OR RAILWAY LOCATION)
 + SNOW DEPTH (PEDESTRIAN LOCATION, SEE NOTE 3)

NOTES:

1. THE MULTIGROUNDED SYSTEM NEUTRAL HAS THE SAME CLEARANCE AS THE 600V SYSTEM.
2. THE VERTICAL CLEARANCES IN THE ABOVE TABLE ARE UNDER MAXIMUM SAG CONDITIONS.
3. REFER TO CSA STANDARD C22.3 No.1, ANNEX D FOR LOCAL SNOW DEPTH VALUES.
4. ALL CLEARANCES ARE IN ACCORDANCE TO CSA STANDARD C22.3.

CONVERSION TABLE

METRIC	IMPERIAL (APPROX)
810cm	27'-0"
760cm	25'-4"
730cm	24'-4"
520cm	17'-4"
480cm	16'-0"
442cm	15'-5"
370cm	12'-4"
340cm	11'-4"
310cm	10'-4"
250cm	8'-4"

REFERENCES

SAGS AND TENSIONS SECTION 02

MINIMUM VERTICAL CLEARANCES OF WIRES, CABLES AND CONDUCTORS ABOVE GROUND OR RAILS

ORIGINAL ISSUE DATE: 2010-DEC-24 REVISION NO: R1 REVISION DATE: 2012-JAN-09

Certificate of Approval

This construction Standard meets the safety requirements of Section 4 of Regulation 22/04

Joe Crozier, P.Eng. 2012-JAN-09
 Name Date

P.Eng. Approval By: Joe Crozier

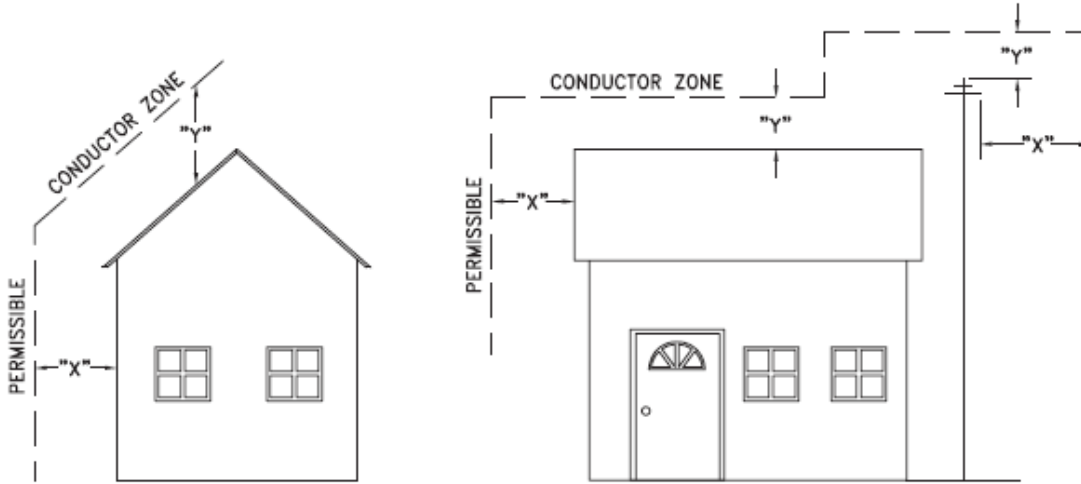

VOLTAGE	MINIMUM HORIZONTAL CLEARANCE UNDER MAXIMUM SWING CONDITIONS DIMENSION "X" (SEE NOTES 1, 3 & 4)	MINIMUM VERTICAL CLEARANCE UNDER MAXIMUM DESIGN SAG CONDITIONS DIMENSION "Y" (SEE NOTES 1, 2, 4 & 5)
0-600V AND NEUTRAL	100cm	250cm
4.16/2.4 TO 44kV	300cm	480cm

NOTES

1. UNDER NO CIRCUMSTANCES SHALL A CONDUCTOR BE PERMITTED TO PENETRATE THE ENVELOPE SHOWN BY THE DOTTED LINE.
2. THE VERTICAL CLEARANCES ARE UNDER CONDITIONS OF MAXIMUM DESIGN SAG.
3. THE HORIZONTAL CLEARANCES ARE UNDER CONDITIONS OF MAXIMUM SWING. WHERE THE CONDUCTOR SWING IS NOT KNOWN A HORIZONTAL CLEARANCE OF 480CM SHALL BE USED.
4. BUILDINGS THAT EXCEED 3 STOREYS OR 15M IN HEIGHT, THE MINIMUM HORIZONTAL CLEARANCE OF THE SECONDARY CONDUCTORS SHOULD BE INCREASED TO 300cm WHERE IT IS NECESSARY TO ALLOW FOR THE RAISING OF LADDERS BY LOCAL FIRE DEPARTMENTS.
5. IN SITUATIONS SUCH AS MULTI-LEVEL GARAGES, WHERE ROOFS ARE NORMALLY USED BY PERSONS AND VEHICLES, THE VERTICAL CLEARANCES OF POWERSTREAM STANDARD 03-1 SHALL APPLY.
6. DISTRIBUTION LINES CONSTRUCTED NEAR BUILDINGS SHALL BE BUILT TO AVOID OVERHANG WHEREVER POSSIBLE. WHERE LINES MUST BE CONSTRUCTED OVER OR ADJACENT TO BUILDINGS THE APPLICABLE HORIZONTAL AND VERTICAL CLEARANCES SHALL BE AT CONDITIONS OF MAXIMUM CONDUCTOR SWING AND MAXIMUM SAG. THE ABOVE CLEARANCES ARE DESIGNED TO PREVENT PERSONS ON OR IN BUILDINGS AS WELL AS EXTERNAL MACHINERY USED IN CONJUNCTION WITH A BUILDING TO COME IN CONTACT WITH CONDUCTORS. EFFORTS SHOULD BE MADE TO INCREASE THESE CLEARANCES WHERE POSSIBLE.
7. ALL CLEARANCES ARE IN ACCORDANCE TO CSA C22.3 NO.1-06 (TABLE-9).

METRIC	IMPERIAL (APPROX)
480cm	16'-0"
300cm	10'-0"
250cm	8'-4"
100cm	3'-4"

MINIMUM VERTICAL & HORIZONTAL CLEARANCES OF CONDUCTORS FROM BUILDINGS OR OTHER PERMANENT STRUCTURES (CONDUCTORS NOT ATTACHED TO BUILDINGS)

Certificate of Approval
This construction Standard meets the safety requirements of Section 4 of Regulation 22/04
Debbie Dadwani, P.Eng. 2010-MAY-05
Name Date
P.Eng. Approval By: D. Dadwani

ORIGINAL ISSUE DATE: 2010-MAY-05 REVISION NO: REVISION DATE:
P:\System Planning and Standards\Standard Design\PowerStream Standards\PowerStream Standards working folder\Section 23-4\DWG 03-4 R0 May 5, 2010.dwg, 5/5/2010 9:27:02 AM, Adobe PDF

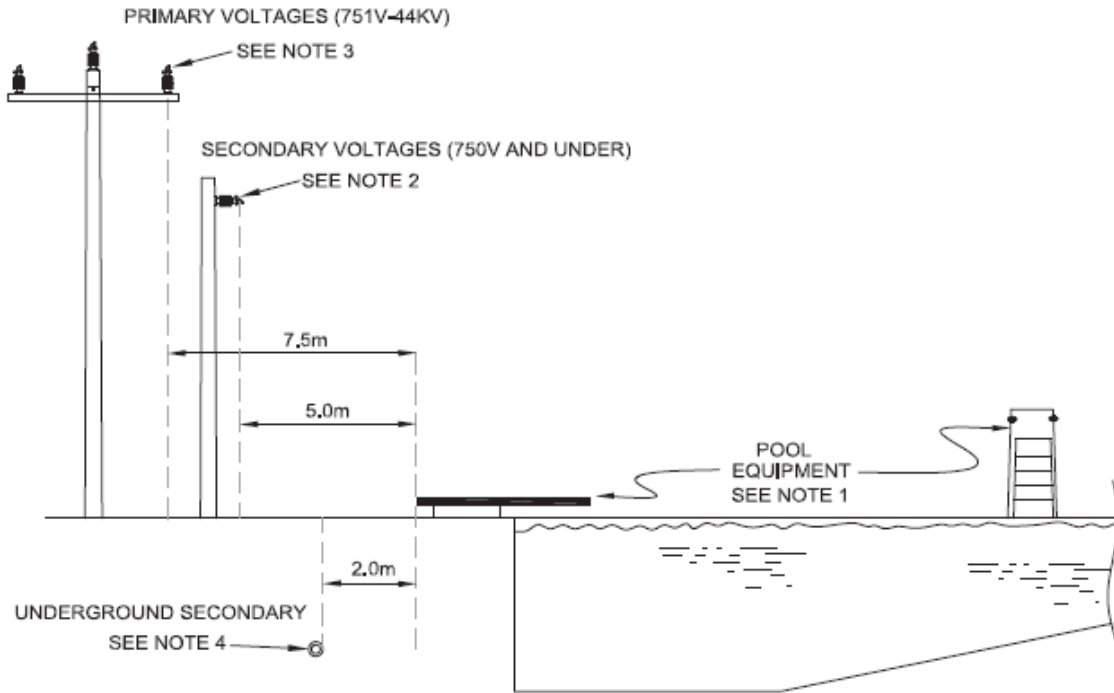

NOTES:

1. ANY STRUCTURE WITHIN 5.0 METRES OF POOL EDGE SHALL BE CONSIDERED PART OF THE POOL.
2. THERE SHALL NOT BE ANY OVERHEAD SECONDARY OR COMMUNICATION WIRING (750V OR LESS) ABOVE THE POOL, AND ABOVE OTHER ELEVATED SURFACES ASSOCIATED WITH THE POOL, INCLUDING BUT NOT RESTRICTED TO A DIVING STRUCTURE, SLIDE, SWINGS, OBSERVATION STAND, TOWER OR PLATFORM, OR ABOVE THE ADJACENT AREA EXTENDING 5.0M HORIZONTALLY FROM THE POOL EDGE.
3. THERE SHALL NOT BE ANY OVERHEAD PRIMARY WIRING (751V - 44KV) ABOVE THE POOL AND OTHER ELEVATED SURFACES ASSOCIATED WITH THE POOL, OR ABOVE THE ADJACENT AREA EXTENDING 7.5M HORIZONTALLY FROM THE POOL EDGE.
4. ANY UNDERGROUND CONDUCTORS SHALL BE 2.0M AWAY FROM POOL EDGE IN DUCT WITH NON-CONDUCTING JACKET. FOR DEPTH AND DUCT DETAILS REFER TO FIGURE 3 IN 25-100 FOR 200A SERVICE AND 25-101 FOR 400A SERVICE RESPECTIVELY, AS PER POWERSTREAM SERVICE DESIGN SPECIFICATIONS.
5. THESE DIMENSIONS APPLY TO ALL SIDES OF THE POOL.

CONVERSION TABLE	
METRIC	IMPERIAL (APPROX.)
7.5m	24'-6"
5.0m	16'-3"
2.0m	6'-6"

REFERENCES	
FIGURE 3, 25-100	SECTION 25
FIGURE 3, 25-101	SECTION 25

MINIMUM CLEARANCES FOR CONDUCTORS ADJACENT TO SWIMMING POOLS

ORIGINAL ISSUE DATE: 2013-JUNE-12 REVISION NO: R0 REVISION DATE:

Certificate of Approval	
This construction Standard meets the safety requirements of Section 4 of Regulation 22/04	
Joe Crozier, P.Eng.	2013-JUN-12
Name	Date
P.Eng. Approval By:	Joe Crozier

To: Committee of Adjustment
From: Sarah Scauzillo, Building Standards Department
Date: April 15, 2026
Applicant: Pool Craft
Location: 67 Wigston Place
 CONC 1 Part of Lot 34
 PLAN 65R33481 Part 1
File No.(s): A005/26

Zoning Classification:

The subject lands are zoned R1A(EN) – First Density Residential Zone (Established Neighbourhood) under Zoning By-law 001-2021, as amended.

#	Zoning By-law 001-2021	Variance requested
1	An accessory building or structure with a height of 2.8 m or greater shall be setback a minimum of 2.4 m to the rear lot line. [Section 4.1.2 1b]	To permit an accessory structure (Cabana) with a height of 2.8 m or greater to be setback a minimum of 0.6 m to the rear lot line.
2	An accessory building or structure with a height of 2.8 m or greater shall be setback a minimum of 2.4 m to the interior side lot line. [Section 4.1.2 1b]	To permit an accessory structure (Cabana) with a height of 2.8 m or greater to be setback a minimum of 2.05 m to the rear lot line.
3	A minimum distance of 0.6 m shall be required from any permitted encroachment to the nearest lot line. [Section 4.13.3.]	To permit a minimum distance of 0.36 m from the Cabana Eaves to the rear lot line.
4	Where lot frontage is 12.0 m or greater, the minimum landscape shall be 50% , of which 60% shall be soft landscape for a yard in which a driveway is located. [Section 4.19.1.2a]	To permit the minimum landscape to be 35% , of which 60% shall be soft landscape for a yard in which a driveway is located.

Staff Comments:

General Comments	
1	The applicant shall be advised that additional variances may be required upon review of detailed drawing for building permit/site plan approval.
2	The subject lands may be subject to Ontario Regulation 166/06 (TRCA - Toronto and Region Conservation Authority).

Conditions of Approval:

If the committee finds merit in the application, the following conditions of approval are recommended.

* Comments are based on the review of documentation supplied with this application.

April 1, 2026

PAR-DPP-2026- 01276
XREF: PER-DPP-2025-01442

SENT BY E-MAIL: Christine.Vigneault@vaughan.ca

Christine Vigneault
Secretary Treasurer
Committee of Adjustment
City of Vaughan
2141 Major Mackenzie Drive
Vaughan, Ontario L6A 1T1

Dear Christine:

**Re: Minor Variance Application- A005/26
CONC 1 Part of Lot 34
67 Wigston Place
City of Vaughan, Regional Municipality of York
Owner: Robert Barron
Agent: Pool Craft (c/o Olusola Egunjobi)**

Toronto and Region Conservation Authority (TRCA) staff reviewed the above noted application, received on March 30, 2026. A list of materials reviewed by TRCA is included in Appendix "A".

The following comments are provided in accordance with TRCA's commenting role under the Planning Act and regulatory permitting role under the Conservation Authorities Act (CA Act). For additional information, please see [Ontario Regulation 686/21: Mandatory Programs and Services](#).

Purpose of the Applications

It is our understanding that the applicant is seeking relief from Zoning By-law 001-2021 as amended, for the following variances to facilitate the construction of a cabana:

- Relief from Section 4.1.2 1b to permit an accessory structure (cabana) with a height of 2.8 m or greater to have a minimum rear yard setback of 0.7 m, whereas the by-law requires a minimum setback of 2.4 m.
- Relief from Section 4.1.2 1b to permit an accessory structure (cabana) with a height of 2.8 m or greater to have a minimum interior side yard setback of 2.05 m, whereas the by-law requires a minimum setback of 2.4 m.
- Relief from Section 4.13.3 to permit a minimum distance of 0.36 m from the cabana eaves to the rear lot line, whereas the by-law requires a minimum distance of 0.6 m.
- Relief from Section 4.19.1.2a to permit a minimum landscape coverage of 35%, whereas the by-law requires a minimum of 50% (with 60% of the required landscaping to be soft landscape).

TRCA Permit Requirement

A portion of the rear yard is located within a TRCA Regulated Area of the Don River Watershed, as it is within the regulated area to a valley corridor of a tributary of the East Don River. As such, any development activity within TRCA's Regulated Area would be subject to a permit in accordance with Section 28.1 of the Conservation Authorities Act.

Application Specific Comments

TRCA staff previously reviewed the proposed works through a TRCA permit (File No. PER-DPP-2025-01442), issued in December 2025. TRCA staff have reviewed the location of the proposed works and the submission materials associated with this minor variance application and note that they are generally consistent with the previously issued permit. Overall, the proposed works are located within an area that is generally flat and consists of manicured lawn situated outside of any natural hazards.

No new development activity is being proposed within TRCA's Regulated Area, as such, a TRCA permit in accordance with Section 28.1 of the CA Act will not be required in this instance. Notwithstanding, TRCA has an interest in all future development on the above-mentioned property as it may be subject to a TRCA permit in accordance with Section 28.1 of the CA Act.

Given the above, staff have no concerns with the Minor Variance Application as currently proposed.

TRCA Plan Review Fee

By copy of this letter, the applicant is advised that this application is subject to a TRCA Planning Review fee in the amount of \$695 (Minor Variance-Residential). The applicant is responsible for fee payment. Please contact the Planner noted below for an electronic invoice to facilitate payment. For more information regarding this fee, the applicant can refer to TRCA's planning services fee schedule: [Fee Schedule for TRCA Development Planning Services](#).

Recommendations

Based on the comments noted above, TRCA staff recommends **conditional approval** of Minor Variance Application **A005/26** based on the following conditions:

1. The applicant submits the variance application review fee of \$695 payable to TRCA.

Sincerely,

Nida Mirza, M.Sc.PI

Planner I

Development Planning and Permits | Development and Engineering Services

Appendix A: Materials Reviewed

- Pool Permit Plan, prepared by unknown author, dated February 23, 2026.
- Drawing No. A1.01, Site Plan, prepared by Evans-Design, Revision No. 4 dated February 27, 2026.

From: [Jane Kelsey](#)
To: [Committee of Adjustment Mailbox](#)
Subject: [External] Re: A005/26 (67 Wigston Place) - Request for Comments (City of Vaughan)
Date: Wednesday, April 8, 2026 10:02:23 AM

CAUTION! This is an external email. Verify the sender's email address and carefully examine any links or attachments before clicking. If you believe this may be a phishing email, please use the Phish Alert Button.

Hello,

I hope this email finds you well.

Thank you for the opportunity to comment on the above referenced application. YCDSB staff have reviewed the application material provided and have no comments or objections to its approval.

Kind regards,



Jane Kelsey, MES (Pl.)
Planner & Project Analyst - Planning Services
York Catholic District School Board
Office: 905-713-1211 ext. 12377
Email: jane.kelsey@ycdsb.ca

From: [Patel, Parthvi R.](#)
To: [Christine Vigneault](#)
Cc: [Committee of Adjustment Mailbox](#)
Subject: [External] RE: A005/26 (67 Wigston Place) - Request for Comments (City of Vaughan)
Date: Tuesday, March 31, 2026 11:35:12 AM

CAUTION! This is an external email. Verify the sender's email address and carefully examine any links or attachments before clicking. If you believe this may be a phishing email, please use the Phish Alert Button.

Hello,

The Regional Municipality of York has reviewed minor variance application A005/26 for 67 Wigston Place and has no comments.

Please provide a copy of the Notice of Decision for our records.

Thank you,

Our working hours may be different. Please do not feel obligated to reply outside of your scheduled working hours. Let's work together to help foster healthy work-life boundaries.

Parthvi Patel | Associate Planner, Development Planning | Economic and Development Services Branch | Corporate Services Department

The Regional Municipality of York | 17250 Yonge Street | Newmarket, ON L3Y 6Z1
1-877-464-9675 | parthvir.patel@york.ca

Our Mission: **Working together to serve our thriving communities – today and tomorrow**

SCHEDULE C: PUBLIC & APPLICANT CORRESPONDENCE

Correspondence Type	Name	Address	Date Received (mm/dd/yyyy)	Summary
N/A				

SCHEDULE D: BACKGROUND

Application No. (City File)	Application Description (i.e. Minor Variance Application; Approved by COA / OLT)
N/A	N/A