

<b>ITEM: 6.8</b>	<b>COMMITTEE OF ADJUSTMENT REPORT SUMMARY MINOR VARIANCE APPLICATION FILE NUMBER A026/23 56 NETHERFORD ROAD, MAPLE</b>
------------------	--

**THIS REPORT CONTAINS COMMENTS FROM THE FOLLOWING  
DEPARTMENTS & AGENCIES:**

\*Please see **Schedule B** of this report for a copy of Development Planning and Agency correspondence.

Additional comments from departments and agencies may be received after the publication of the Staff Report. These comments will be processed as an addendum and posted on the City's Website.

<b>DEPARTMENTS</b>	<b>Circulated</b>	<b>Comments Received</b>	<b>Conditions</b>	<b>Nature of Comments</b>
Committee of Adjustment	<input checked="" type="checkbox"/>	<input checked="" type="checkbox"/>	<input type="checkbox"/>	General Comments
Building Standards (Zoning Review)	<input checked="" type="checkbox"/>	<input checked="" type="checkbox"/>	<input type="checkbox"/>	General Comments
Building Inspection (Septic)	<input checked="" type="checkbox"/>	<input type="checkbox"/>	<input type="checkbox"/>	No Comments Received to Date
Development Planning	<input checked="" type="checkbox"/>	<input checked="" type="checkbox"/>	<input type="checkbox"/>	Recommend Approval/No Conditions
Development Engineering	<input checked="" type="checkbox"/>	<input checked="" type="checkbox"/>	<input checked="" type="checkbox"/>	Recommend Approval w/Conditions
Parks, Forestry and Horticulture Operations	<input checked="" type="checkbox"/>	<input checked="" type="checkbox"/>	<input checked="" type="checkbox"/>	General Comments w/conditios
By-law & Compliance, Licensing & Permits	<input checked="" type="checkbox"/>	<input type="checkbox"/>	<input type="checkbox"/>	No Comments Received to Date
Development Finance	<input checked="" type="checkbox"/>	<input checked="" type="checkbox"/>	<input type="checkbox"/>	General Comments
Real Estate	<input type="checkbox"/>	<input type="checkbox"/>	<input type="checkbox"/>	
Fire Department	<input checked="" type="checkbox"/>	<input type="checkbox"/>	<input type="checkbox"/>	No Comments Received to Date
<b>AGENCIES</b>	<b>Circulated</b>	<b>Comments Received</b>	<b>Conditions</b>	<b>Nature of Comments</b>
TRCA	<input checked="" type="checkbox"/>	<input type="checkbox"/>	<input type="checkbox"/>	No Comments Received to Date
Ministry of Transportation (MTO)	<input type="checkbox"/>	<input type="checkbox"/>	<input type="checkbox"/>	
Region of York	<input checked="" type="checkbox"/>	<input type="checkbox"/>	<input type="checkbox"/>	No Comments Received to Date
Alectra	<input checked="" type="checkbox"/>	<input checked="" type="checkbox"/>	<input type="checkbox"/>	General Comments
Bell Canada	<input checked="" type="checkbox"/>	<input type="checkbox"/>	<input type="checkbox"/>	No Comments Received to Date
YRDSB	<input type="checkbox"/>	<input type="checkbox"/>	<input type="checkbox"/>	
YCDSB	<input type="checkbox"/>	<input type="checkbox"/>	<input type="checkbox"/>	
CN Rail	<input type="checkbox"/>	<input type="checkbox"/>	<input type="checkbox"/>	
CP Rail	<input type="checkbox"/>	<input type="checkbox"/>	<input type="checkbox"/>	
TransCanada Pipeline	<input checked="" type="checkbox"/>	<input type="checkbox"/>	<input type="checkbox"/>	No Comments Received to Date
Metrolinx	<input type="checkbox"/>	<input type="checkbox"/>	<input type="checkbox"/>	
Propane Operator	<input type="checkbox"/>	<input type="checkbox"/>	<input type="checkbox"/>	

**PUBLIC & APPLICANT CORRESPONDENCE**

\*Please see **Schedule C** of this report for a copy of the public & applicant correspondence listed below.

The deadline to submit public comments is **noon on the last business day prior to the scheduled hearing date.**

Comments and written public submissions received after the publication of this Staff Report will be processed as an addendum and posted on the City's Website.

All personal information collected because of this public meeting (including both written and oral submissions) is collected under the authority of the Municipal Act, the Municipal Freedom of Information and Protection of Privacy Act (MFIPPA), the Planning Act and all other relevant legislation, and will be used to assist in deciding on this matter. All personal information (as defined by MFIPPA), including (but not limited to) names, addresses, opinions and comments collected will become property of the City of Vaughan, will be made available for public disclosure (including being posted on the internet) and will be used to assist the Committee of Adjustment and staff to process this application.

<b>Correspondence Type</b>	<b>Name</b>	<b>Address</b>	<b>Date Received (mm/dd/yyyy)</b>	<b>Summary</b>
None				

**PREVIOUS COA DECISIONS ON THE SUBJECT LAND**

\*Please see **Schedule D** for a copy of the Decisions listed below

<b>File Number</b>	<b>Date of Decision</b>	<b>Decision Outcome</b>
--------------------	-------------------------	-------------------------

**PREVIOUS COA DECISIONS ON THE SUBJECT LAND**

\*Please see **Schedule D** for a copy of the Decisions listed below

	MM/DD/YYYY	
None		

**ADJOURNMENT HISTORY**

\* Previous hearing dates where this application was adjourned by the Committee and public notice issued.

None	
------	--



**COMMITTEE OF ADJUSTMENT REPORT  
MINOR VARIANCE APPLICATION  
A026/23  
56 NETHERFORD ROAD, MAPLE**

<b>ITEM NUMBER: 6.8</b>	<b>CITY WARD #: 1</b>
<b>APPLICANT:</b>	Linda Holt
<b>AGENT:</b>	Rebecca Muise, David Small Designs
<b>PROPERTY:</b>	56 Netherford Road, Maple
<b>ZONING DESIGNATION:</b>	See Below
<b>VAUGHAN OFFICIAL PLAN (2010) DESIGNATION:</b>	Vaughan Official Plan 2010 ('VOP 2010'): "Low-Rise Residential"
<b>RELATED DEVELOPMENT APPLICATIONS:</b>	None
<b>PURPOSE OF APPLICATION:</b>	Relief from the Zoning By-law is being requested to permit the construction of a proposed single family dwelling (with attached garage and covered porch), cabana, and swimming pool.

The following variances have been requested from the City's Zoning By-law:

**The subject lands are zoned R1E(EN) – First Density Residential Zone (Established Neighbourhood) and subject to the provisions of Exception 14.534 under Zoning By-law 001-2021, as amended.**

#	Zoning By-law 001-2021	Variance requested
1	A maximum lot coverage of 23% is required [Table 7-3].	To permit a maximum lot coverage of 27.45%
2	A maximum height of 8.5 metres is required [Section 4.5.1.b.]	To permit a maximum height of 9.08 metres for the dwelling.
3	In any Residential zone, the maximum height of a residential accessory structure shall be 3.0 m. [Section 4.1.4.1].	To permit a maximum height of 3.81 metres for a residential accessory structure.

**HEARING INFORMATION**

**DATE OF MEETING:** Thursday, April 20, 2023  
**TIME:** 6:00 p.m.  
**MEETING LOCATION:** Vaughan City Hall, **Woodbridge Room**, 2141 Major Mackenzie Drive, Vaughan  
**LIVE STREAM LINK:** [Vaughan.ca/LiveCouncil](http://Vaughan.ca/LiveCouncil)

**PUBLIC PARTICIPATION**

If you would like to speak to the Committee of Adjustment at the meeting, either remotely or in person, please complete the [Request to Speak Form](#) and submit to [cofa@vaughan.ca](mailto:cofa@vaughan.ca)  
 If you would like to submit written comments, please quote file number above and submit by mail or email to:

**Email:** [cofa@vaughan.ca](mailto:cofa@vaughan.ca)

**Mail:** City of Vaughan, Office of the City Clerk, Committee of Adjustment, 2141 Major Mackenzie Drive, Vaughan, ON, L6A 1T1

**THE DEADLINE TO REGISTER TO SPEAK OR SUBMIT WRITTEN COMMENTS ON THE ABOVE NOTED FILE(S) IS NOON ON THE LAST BUSINESS DAY BEFORE THE MEETING.**

**INTRODUCTION**

Staff and Agencies act as advisory bodies to the Committee of Adjustment. The comments contained in this report are presented as recommendations to the Committee.

Section 45(1) of the Planning Act sets the criteria for authorizing minor variances to the City of Vaughan's Zoning By-law. Accordingly, review of the application may consider the following:

- That the general intent and purpose of the by-law will be maintained.
- That the general intent and purpose of the official plan will be maintained.

## INTRODUCTION

That the requested variance(s) is/are acceptable for the appropriate development of the subject lands.  
That the requested variance(s) is/are minor in nature.

Public written and oral submissions relating to this application are taken into consideration by the Committee of Adjustment as part of its deliberations and final decision on this matter.

## COMMITTEE OF ADJUSTMENT COMMENTS

<b>Date Public Notice Mailed:</b>	April 13, 2023 (Application rescheduled to April 24 to accommodate statutory public notice)
<b>Date Applicant Confirmed Posting of Sign:</b>	April 3, 2023
<b>Applicant Justification for Variances:</b> <small>*As provided by Applicant in Application Form</small>	We are asking for relief on overall coverage, dwelling height and cabana height. Permitted coverage is 20% [Zoning Bylaw 1- 88, Schedule A] and 23% [Zoning Bylaw 001-2021, Table 7-3] and 23%. The dwelling, including the attached garage, is just over the required 20%; it's the covered porch areas and cabana that push the coverage to 29.11%. This is a deep property. We believe the covered porch areas and cabana structure in the rear yard are appropriate for this lot. The dwelling height is 9.08m, where the permitted is 8.5m. The architectural style required a steep pitch to the roofline, resulting in a high midpoint of the sloped roof. Living space is enclosed in the roofline, creating a respectful and appropriate façade. The cabana structure was designed to align with the architectural style of the home, resulting in the same steep pitch in the roofline and height variance. We believe these variances to be minor in nature and appropriate, following the original intent of the zoning bylaws.
<b>Adjournment Requests (from staff):</b> <small>*Adjournment requests provided to applicant prior to issuance of public notice</small>	<p>On April 3, 2023, Development Planning advised:</p> <p>It has come to the attention of Development Planning that A026/23 was recently added to the April 20<sup>th</sup> agenda and has not been circulated to urban design staff. Furthermore, we require arborist report to complete our analyses and ensure the vegetation within 6 m of the proposed construction will not be impacted. Note this request was brought to your attention in an email I sent on March 9, 2023.</p> <p>On April 4, 2023, COA Staff provided applicant opportunity to adjourn application.</p> <p>On April 4, 2023, the applicant advised that they wish to proceed to the April 20 Committee of Adjustment hearing.</p>
<b>Was a Zoning Review Waiver (ZRW) Form submitted by Applicant:</b>  <small>*ZRW Form may be used by applicant in instances where a revised submission is made, and zoning staff do not have an opportunity to review and confirm variances prior to the issuance of public notice.</small>  <small>*A revised submission may be required to address staff / agency comments received as part of the application review process.</small>  <small>*Where a zoning review has not been completed on a revised submission, an opportunity is provided to the applicant to adjourn the proposal prior to the issuance of public notice.</small>	No
<b>Adjournment Fees:</b> In accordance with Procedural By-law 069-2019, an Adjournment Fee is applicable to reschedule an application after the issuance of public notice where a request for adjournment has been provided to the applicant prior to the issuance of public notice.  An Adjournment Fee can only be waived in instances where adjournment of an application is requested by the Committee or staff <b>after</b> the issuance of public notice.	
<b>Committee of Adjustment Comments:</b>	None
<b>Committee of Adjustment Recommended Conditions of Approval:</b>	None

### BUILDING STANDARDS (ZONING) COMMENTS

\*\*See Schedule B for Building Standards (Zoning) Comments

<b>Building Standards Recommended Conditions of Approval:</b>	None
---	------

### DEVELOPMENT PLANNING COMMENTS

\*\*See Schedule B for Development Planning Comments.

<b>Development Planning Recommended Conditions of Approval:</b>	None
---	------

### DEVELOPMENT ENGINEERING COMMENTS

[Link to Grading Permit](#) [Link to Pool Permit](#) [Link to Curb Curt Permit](#) [Link Culvert Installation](#)

As the proposed 2-storey residence in the subject property is 354.9 m<sup>2</sup>, the Owner / Applicant needs to obtain a Lot Grading Permit from Development Inspection and Lot Grading Division of the City's Development Engineering Department. Please note any in-ground structure over 10 m<sup>2</sup> requires a Grading Permit. Please contact the Development Engineering Reviewer after receiving the Grading Permit to clear the condition. (Condition attached)

The Owner / Applicant shall apply for a Pool Grading Permit with the Development Engineering (DE) Department. Please visit the grading permits page at City of Vaughan website to learn how to apply for the Pool Permit. If you have any question about Pool Grading Permit, please contact the Development Engineering Department through email at [DEPermits@vaughan.ca](mailto:DEPermits@vaughan.ca).

The proposed work by the Owner/ Applicant is increasing the lot coverage on the subject property. The added hardscape may have impacts on the City's Storm Water management system. Development Engineering strongly encourages the Owner / Applicant introduce Low-Impact Development (LID) measures (e.g., bioswales, permeable pavers, rain gardens, rain barrels etc.) to reduce the impacts to the stormwater system. Should further information be required, please contact the Development Engineering COA reviewer.

The Development Engineering Department does not object to the Minor Variance application A026/23, subject to the following condition(s):

<b>Development Engineering Recommended Conditions of Approval:</b>	The Owner / Applicant shall submit the final Lot Grading and/or Servicing Plan to the Development Inspection and Lot Grading Division of the City's Development Engineering Department for final Lot Grading and/or Servicing Permit prior to any work being undertaken on the property. Please visit the Grading Permit page at City of Vaughan website to learn how to apply for the Grading Permit. If you have any questions about Grading Permit, please contact the Development Engineering Department by email at <a href="mailto:DEPermits@vaughan.ca">DEPermits@vaughan.ca</a> .
--	---

### PARKS, FORESTRY & HORTICULTURE (PFH) COMMENTS

Recommended condition of approval:

<b>PFH Recommended Conditions of Approval:</b>	Applicant/owner shall obtain a "Private Property Tree Removal & Protection" permit through the forestry division prior to any construction works on the subject property.
--	---

### DEVELOPMENT FINANCE COMMENTS

No comment no concerns

<b>Development Finance Recommended Conditions of Approval:</b>	None
--	------

### BY-LAW AND COMPLIANCE, LICENSING AND PERMIT SERVICES COMMENTS

No comments received to date.

<b>BCLPS Recommended Conditions of Approval:</b>	None
--	------

### BUILDING INSPECTION (SEPTIC) COMMENTS

No comments received to date.

## BUILDING INSPECTION (SEPTIC) COMMENTS

<b>Building Inspection Recommended Conditions of Approval:</b>	None
--	------

## FIRE DEPARTMENT COMMENTS

No comments received to date.	
<b>Fire Department Recommended Conditions of Approval:</b>	None

## SCHEDULES TO STAFF REPORT

\*See Schedule for list of correspondence

<b>Schedule A</b>	Drawings & Plans Submitted with the Application
<b>Schedule B</b>	Staff & Agency Comments
<b>Schedule C</b> (if required)	Correspondence (Received from Public & Applicant)
<b>Schedule D</b> (if required)	Previous COA Decisions on the Subject Land

Should the Committee find it appropriate to approve this application in accordance with request and the sketch submitted with the application, as required by Ontario Regulation 200/96, the following conditions have been recommended:

## SUMMARY OF RECOMMENDED CONDITIONS OF APPROVAL

All conditions of approval, unless otherwise stated, are considered to be incorporated into the approval “**if required**”. If a condition is no longer required after an approval is final and binding, the condition may be waived by the respective department or agency requesting conditional approval. A condition cannot be waived without written consent from the respective department or agency.

#	DEPARTMENT / AGENCY	CONDITION(S) DESCRIPTION
1	Development Engineering <a href="mailto:Rex.bondad@vaughan.ca">Rex.bondad@vaughan.ca</a>	The Owner / Applicant shall submit the final Lot Grading and/or Servicing Plan to the Development Inspection and Lot Grading Division of the City’s Development Engineering Department for final Lot Grading and/or Servicing Permit prior to any work being undertaken on the property. Please visit the Grading Permit page at City of Vaughan website to learn how to apply for the Grading Permit. If you have any questions about Grading Permit, please contact the Development Engineering Department by email at DEPermits@vaughan.ca.
2	Parks, Forestry and Horticulture Operations <a href="mailto:zachary.quizzetti@vaughan.ca">zachary.quizzetti@vaughan.ca</a>	Applicant/owner shall obtain a “Private Property Tree Removal & Protection” permit through the forestry division prior to any construction works on the subject property.

## IMPORTANT INFORMATION – PLEASE READ

**CONDITIONS:** It is the responsibility of the owner/applicant and/or authorized agent to obtain and provide a clearance letter from respective department and/or agency (**see condition chart above for contact**). This letter must be provided to the Secretary-Treasurer to be finalized. All conditions must be cleared prior to the issuance of a Building Permit.

## IMPORTANT INFORMATION – PLEASE READ

**APPROVALS:** Making any changes to your proposal after a decision has been made may impact the validity of the Committee's decision.

An approval obtained from the Committee of Adjustment, where applicable, is tied to the building envelope shown on the plans and drawings submitted with the application and subject to the variance approval.

A building envelope is defined by the setbacks of the buildings and/or structures shown on the plans and drawings submitted with the application, as required by Ontario Regulation 200/96. Future development outside of an approved building envelope, where a minor variance was obtained, must comply with the provisions of the City's Zoning By-law.

Elevation drawings are provided to reflect the style of roof (i.e. flat, mansard, gable etc.) to which a building height variance has been applied. Where a height variance is approved, building height is applied to the style of roof (as defined in the City's Zoning By-law) shown on the elevation plans submitted with the application.

Architectural design features that are not regulated by the City's Zoning By-law are not to be considered part of an approval unless specified in the Committee's decision.

**DEVELOPMENT CHARGES:** That the payment of the Regional Development Charge, if required, is payable to the City of Vaughan before issuance of a building permit in accordance with the Development Charges Act and the Regional Development Charges By-law in effect at the time of payment.

That the payment of the City Development Charge, if required, is payable to the City of Vaughan before issuance of a building permit in accordance with the Development Charges Act and the City's Development Charges By-law in effect at the time of payment.

That the payment of the Education Development Charge if required, is payable to the City of Vaughan before issuance of a building permit in accordance with the Development Charges Act and the Boards of Education By-laws in effect at the time of payment

That the payment of Special Area Development charge, if required, is payable to the City of Vaughan before issuance of a building permit in accordance with the Development Charges Act and The City's Development Charge By-law in effect at the time of Building permit issuance to the satisfaction of the Reserves/Capital Department.

**NOTICE OF DECISION:** If you wish to be notified of the decision in respect to this application or a related Ontario Land Tribunal (OLT) hearing you must complete a Request for Decision form and submit to the Secretary Treasurer (ask staff for details). In the absence of a written request to be notified of the Committee's decision you will **not** receive notice.

**SCHEDULE A: DRAWINGS & PLANS**



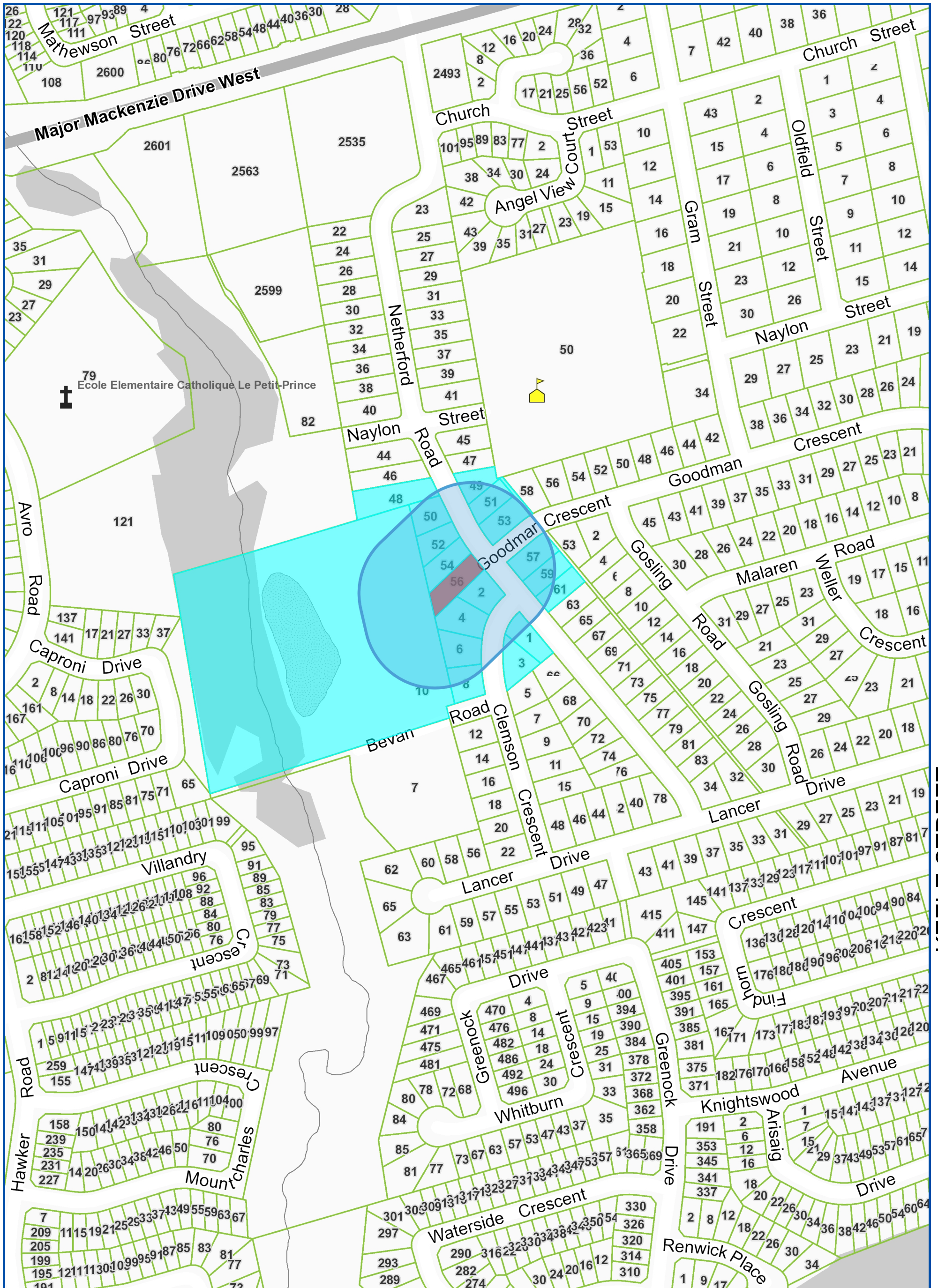

KEELE STREET

**Map Information:**

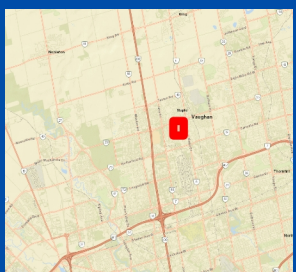

**Title:**

56 Netherford Road, Maple

**NOTIFICATION MAP - A026/23**

**Disclaimer:**

Every reasonable effort has been made to ensure that the information appearing on this map is accurate and current. We believe the information to be reliable, however the City of Vaughan assumes no responsibility or liability due to errors or omissions. Please report any discrepancies to Infrastructure Programming.



Scale: 1: 4,514

0 0.07 km



**Created By:**

Infrastructure Delivery  
Department  
April 4, 2023 6:59 AM

Projection:  
NAD 83  
UTM Zone  
17N

# PLANS PREPARED AND VARIANCES IDENTIFIED BY APPLICANT

# A026/23

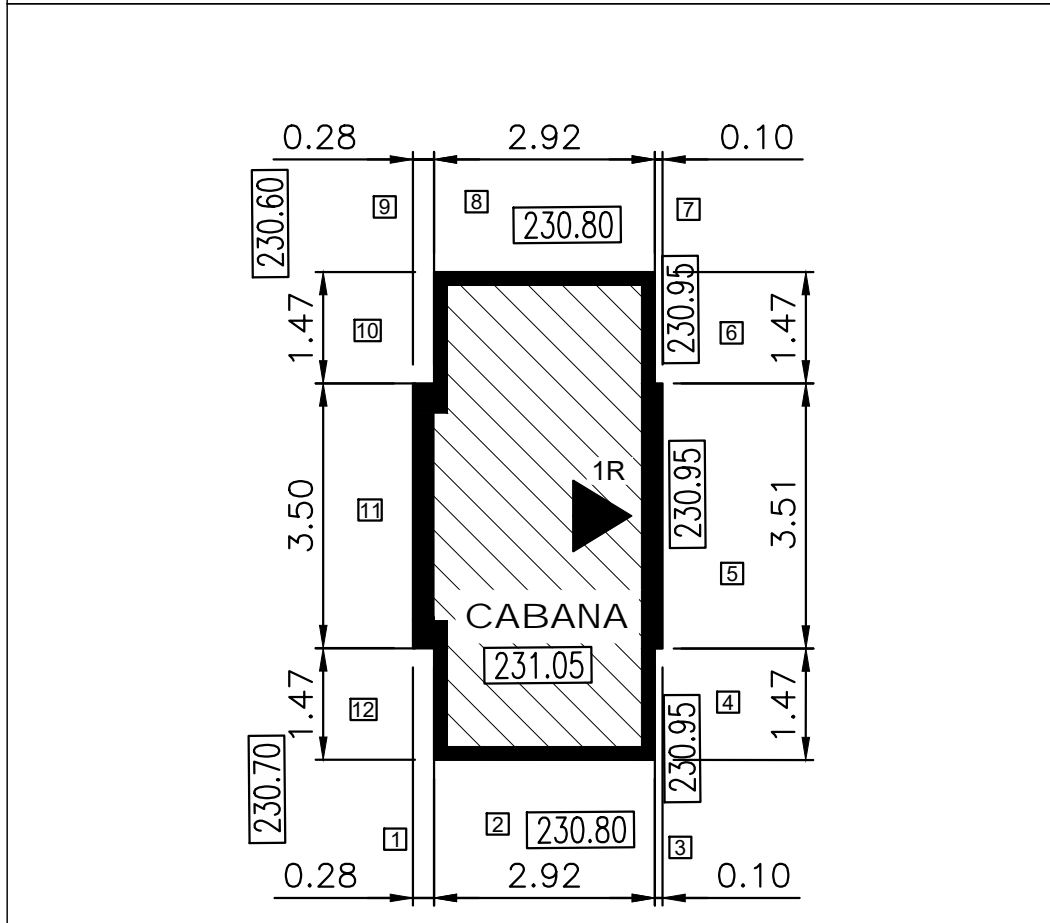
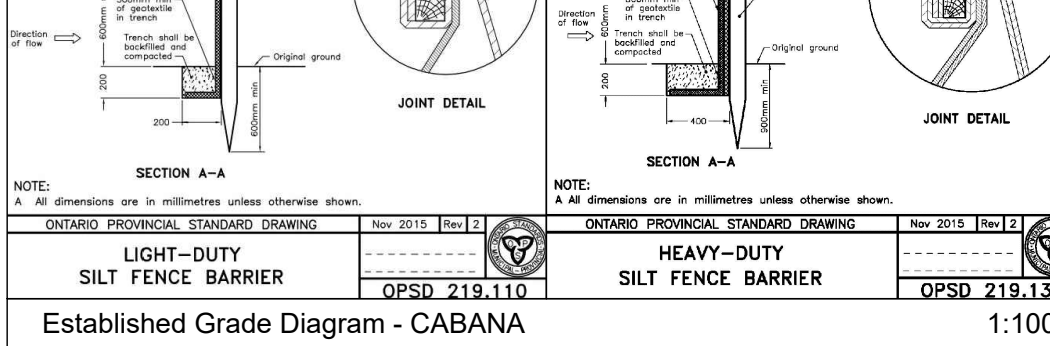
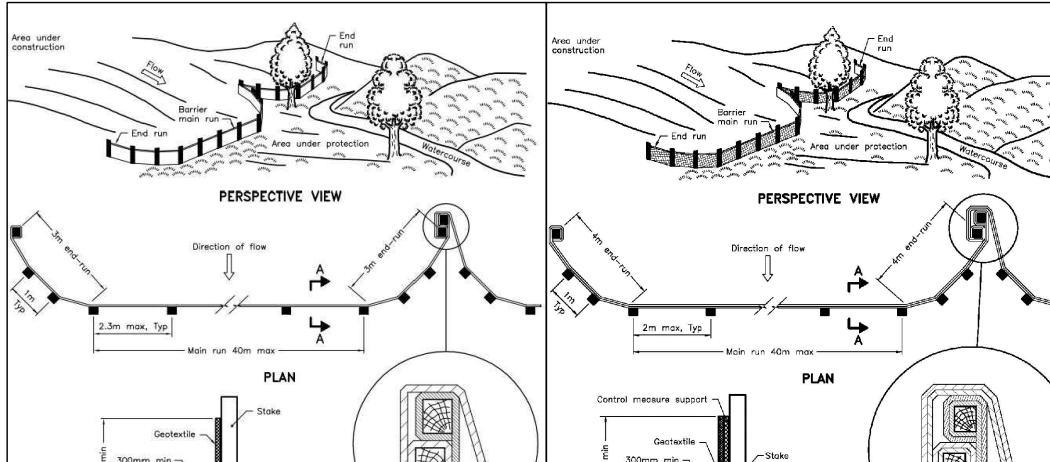

Wall No.	Wall Average Grade	Wall Length (m)	Product	
1	230.75	0.28	64.61	
2	230.80	2.92	673.94	
3	230.85	0.10	23.09	
4	230.95	1.47	339.50	
5	230.95	3.51	810.63	
6	230.95	1.47	339.50	
7	230.87	0.10	23.09	
8	230.80	2.92	673.94	
9	230.78	0.28	64.62	
10	230.75	1.47	339.22	
11	230.75	3.50	807.56	
12	230.70	1.47	339.13	
Total		2769.89	18.49	4988.80

Established Grade = Total Product Divided By Total Wall Length = 230.83

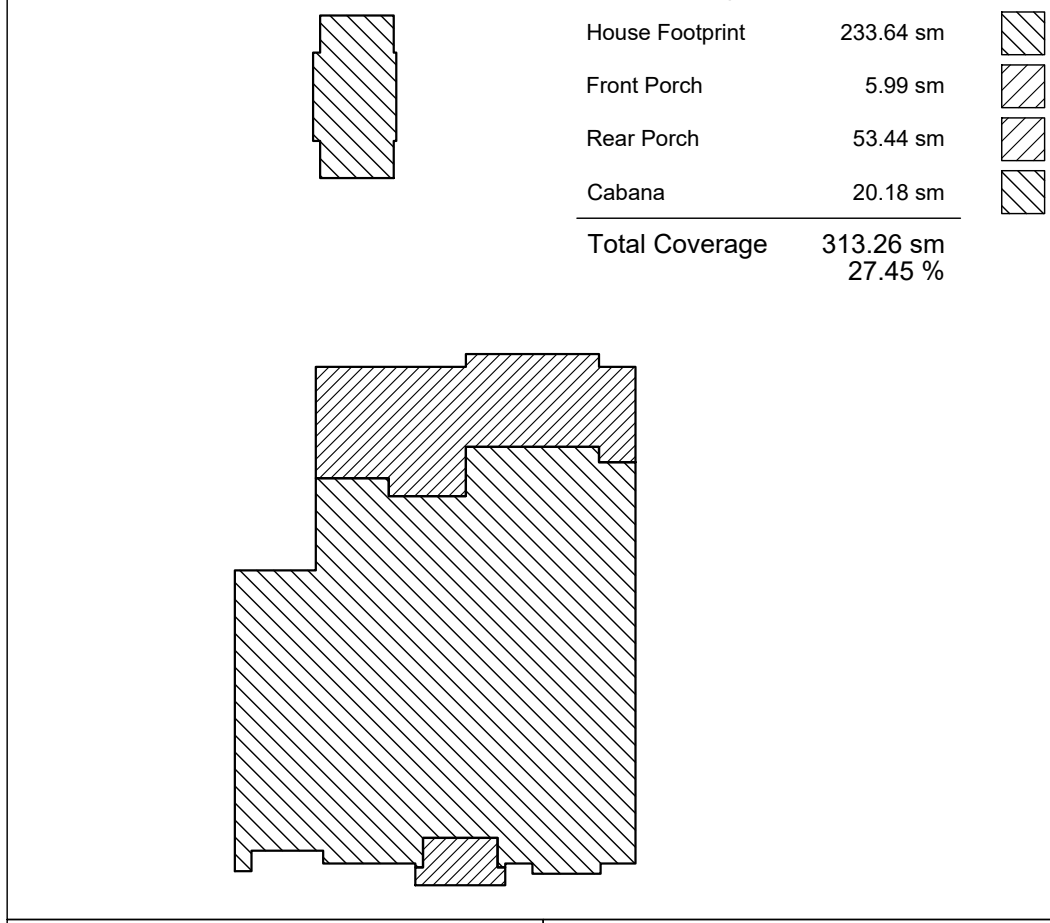

Symbol	Description
3R	Main Level Entrance/Exit
3R	Lower Level Entrance/Exit
---	Property Line
---	Existing To Be Removed
102.05	Proposed Spot Elevation
AC	Rainwater Downspouts
AC	Air Conditioner
---	Solid Hoarding
---	Framed Hoarding
---	ESC Or Sit Fence Hoarding
AD	Area Drain
0.300C	Denotes Coniferous Tree (with trunk diameter) To Remain
0.300D	Denotes Deciduous Tree (with trunk diameter) To Remain
0.300X	Denotes Tree (with trunk diameter) To Be Removed
RH	Denoted Replacement Tree Native Species Min 60mm Caliper For Deciduous And 1.8m Height For Coniferous
SPECIES	(SPECIES) Refers To Type of Replacement Tree As Per Arborist Report
#	Denotes Tree Number Corresponding w Arborist Report
H.P.	Denotes Grading High Point

- General Notes:**
- Do Not Scale Drawings
  - These Plans Are To Remain The Property Of The Designer And Must Be Returned Upon Request. These Plans Must Not Be Used In Any Other Location Without The Written Approval Of The Designer.
  - All Works To Be In Accordance With The Ontario Building Code And All Code References Refer To O.B.C. 2012 Division V

**ESC Notes:**

- The Contractor is Ultimately Responsible For Controlling Sediment & Erosion Within The Construction Site For The Total Period Of The Construction. The Sediment Laden Water Will Not Be Allowed To Discharge To The Lake.
- After Hours Contact Number Is To Be Displayed On-Site For Emergencies. All Plans Should Have Name And Contact Info Of The Person Responsible For ESC Measures.
- Any Sediment Spill From The Site Must Be Reported To Ministry Of Environment And Climate Change (Call Spill Action Center At 1 800 268 6060).
- All Activities, Including Maintenance Procedure Shall Be Controlled To Prevent The Entry Of Petroleum Products, Debris, Rubble, Concrete Or Other Deleterious Substances Into Water. Vehicular Maintenance Shall Be Conducted 30 M From The Water.
- Any Operation That Creates Dust, Such As Stone Cutting, Concrete Cutting, Shall Be Carried Out Away From The Water.
- Maintain Temporary Erosion Control And Pollution Control Features Installed Under This Contract. Erosion And Sediment Controls Methods Are To Be Continuously Evaluated, And Upgrades Are To Be Implemented, When Necessary.
- Temporary Oil Or Dirt Stockpiles Are To Be Provided With Necessary Sediment And Erosion Control Features, Including Seeding If Anticipated To Be Stored More Than One Month.
- Additional Erosion And Sediment Control Materials (I.E. Silt Fence, Straw Bales, Clear Stones, Etc.) Are To Be Kept On Site For Emergencies And Repairs.
- Erosion And Sediment Controls Methods Are To Be Continuously Evaluated, And Upgrades Are To Be Implemented, When Necessary.

**Top of Foundation Wall Conditions 1:20**

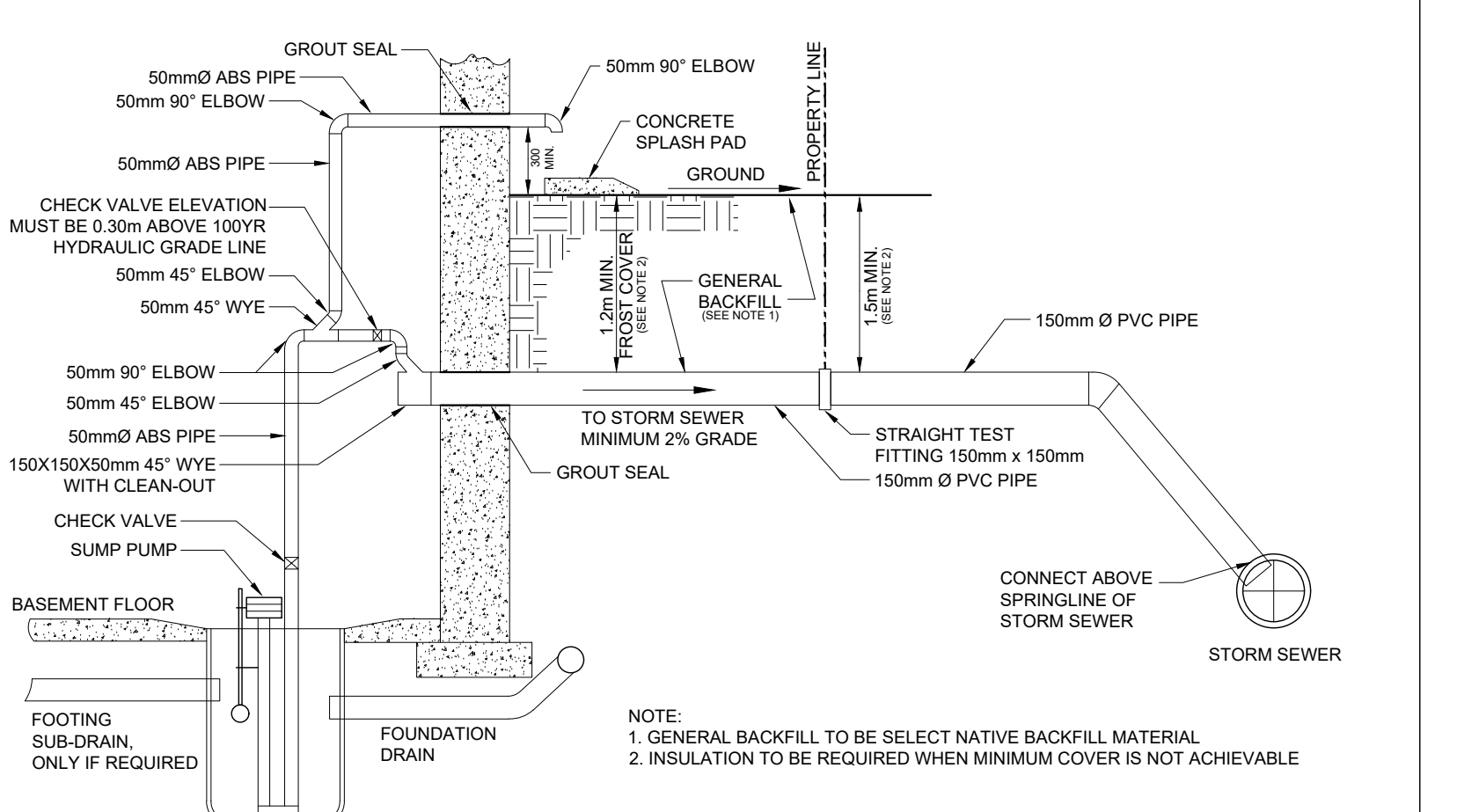
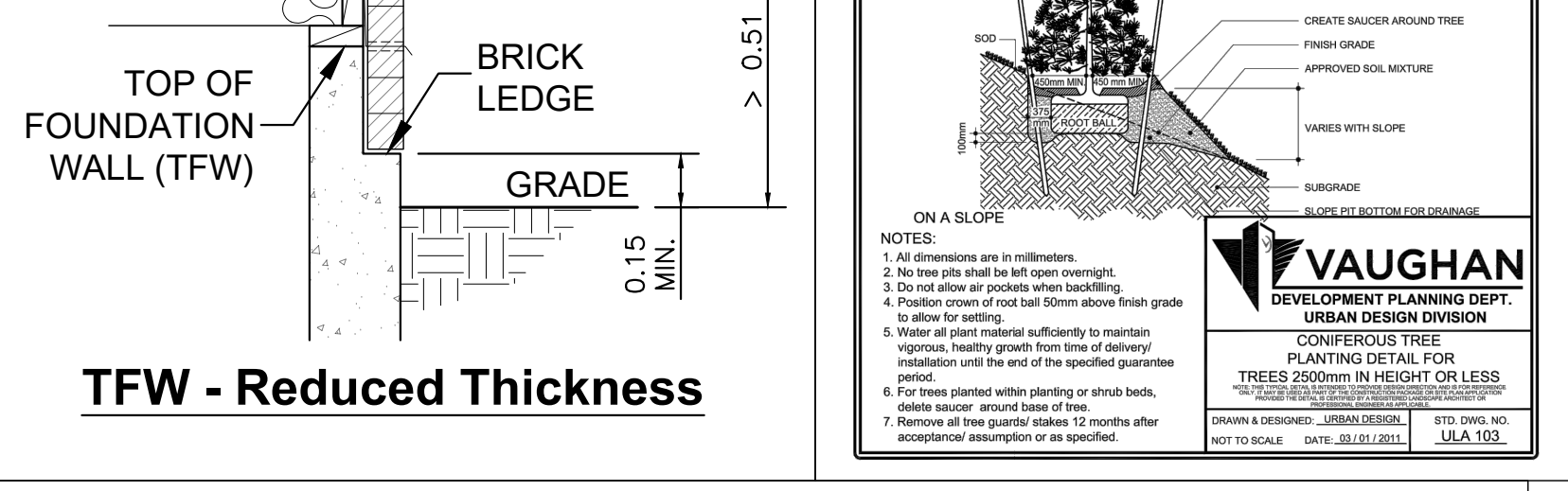
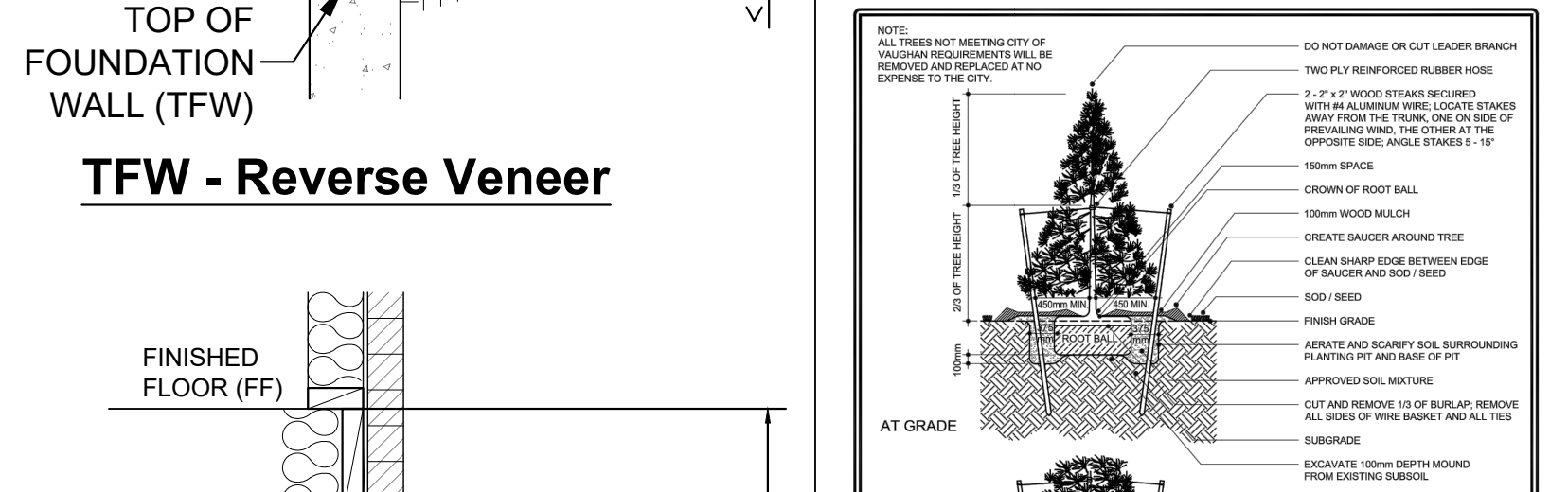
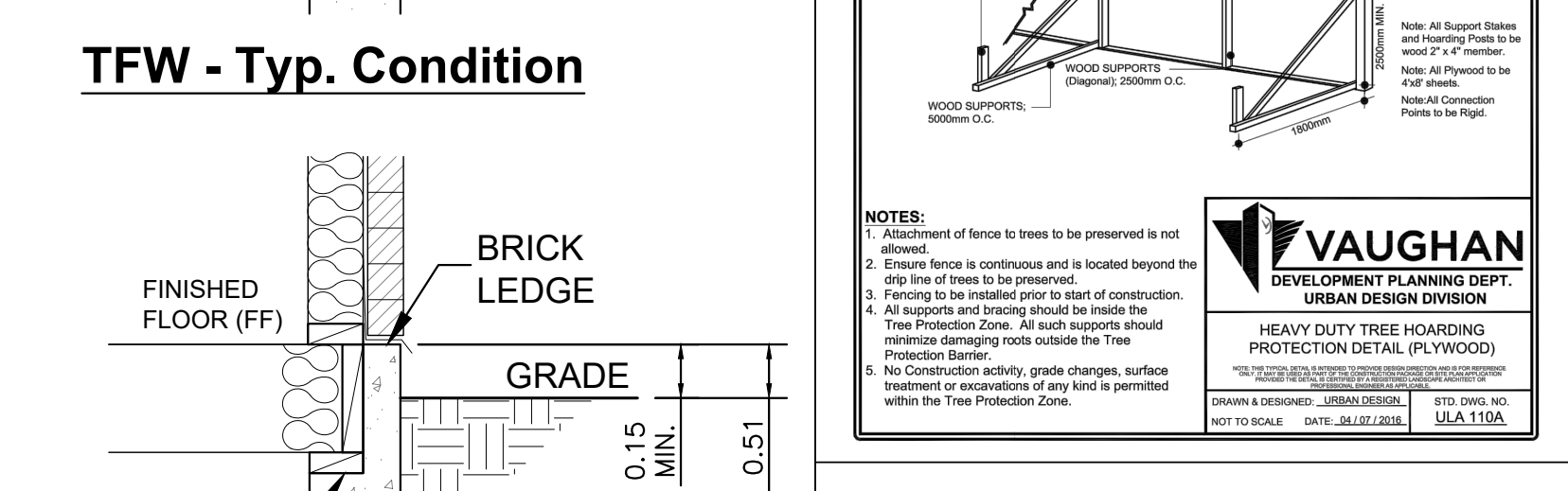
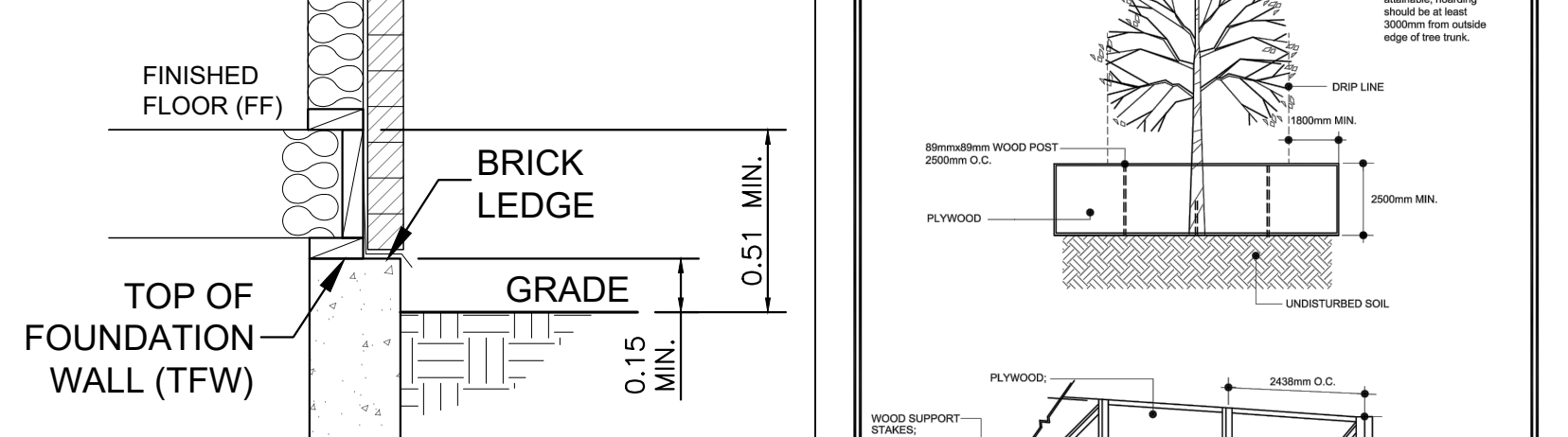

**CITY OF VAUGHAN DEVELOPMENT/ TRANSPORTATION ENGINEERING DEPARTMENT LOT GRADING NOTES**

- The Following Notes Apply To The Construction Governed By The Reference Permit And Shall Form Part Of The Drawings Attached Hereto:
- All Site Plans, Drawings And Construction Shall Comply With The City Of Vaughan Lot Grading Criteria, City Of Vaughan Engineering Standards, And Applicable Provincial Standards. The Ontario Building Code, Subdivision Agreement And By-Law 1-88 Unless Otherwise Approved.
  - Approval Of This Site Plan Does Not Release The Builder/Applicant/Owner Of Their Responsibilities To Ensure The Proposed Drainage Works Are Compatible With The Overall Drainage Within The Subdivision. Proposed Lot Drainage Shall Not Adversely Affect Adjacent Properties.
  - Alterations To Existing Grades Shall Not Be Permitted Within 600mm Of Lot Lines Unless Specifically Approved As Part Of This Permit. The Approved Grading/Drainage Pattern For This Lot/Block Shall Be Maintained And Alterations Not Approved As Part Of This Permit Shall Be Restored By The Builder/Applicant/Owner To The Satisfaction Of The City Of Vaughan.
  - Sedimentation/Siltation Control Measures Shall Be Installed Prior To Construction And Offset A Minimum Of 600mm From Lot Lines. These Measures Shall Be Maintained In Order To Prevent Adversely To Adjacent Lands. Refer To Attached Sample Drawing.
  - Sanitary And Storm Inlets/Elevations Shall Be Shown At Main Lateral Connection And At Property Line. City Engineering Department/Work Report Approval Is Required For Sanitary, Storm And Water Box Location And Installation To The Lot Line Prior To Construction.
  - Water, Storm And Sanitary Lines That Are To Be Reused Or Decommissioned Are To Be Identified On The Drawing.
  - Downspouts Of Rain Water Leaders Shall Discharge Into Splash Pads And Drain Towards The Street. Splash Pads Shall Outlet Over Sodded Land Where Possible. To Encourage Infiltration Of Surface Runoff.
  - High Point On Silt Lot Drainage To Be A Minimum Of 2.0m Behind Front Downspout Location To Ensure Drainage Outlets To Street.
  - Top Of Foundation Walls, Exterior Cladding, Window And Door Sills Shall Be A Minimum Of 150mm Above Finished Grade.
  - The Designer/Consultant/Engineer/Architect Is Responsible To Ensure That Height, Thickness, Lateral Bracing, Etc. Of All Foundation Walls Conform To OBC, OBC Subsection 9.1.5.4 Shall Apply.
  - All Front And Rear Yards Shall Be Graded At A 2% - 5% Gradient Within 5m Of The Footing.
  - Drainage Swales Shall Be Graded With A 2% - 5% Gradient. Desirable Swale Depth Is 250mm. Minimum Swale Depth Is 150mm. Maximum Swale Depth Is Variable And Depends On Location And Safety Considerations, But Must Not Exceed 300mm.
  - Centerline Of Swales Shall Be Located 600mm From Lot Lines Unless Otherwise Approved.
  - Artificial Embankments And/or Retaining Walls Shall Not Be Permitted Unless Approved As Part Of This Permit. The Maximum Embankment Slope Shall Be 3:1 (Horizontal To Vertical) With A Maximum Grade Differential Of 600mm.
  - Proposed Retaining Walls Are To Be Constructed In Accordance With The City Of Vaughan Lot Grading Criteria And By-Law 1-88. Retaining Walls Exceeding 1.0 Metre In Height Shall Be Designed, Inspected And Certified By A Professional Engineer And Shall Be Served By Guards Or Otherwise Treated To Reduce Any Public Hazard. Retaining Walls Shall Be Constructed Of Concrete, Precast Blocks Or Concrete. A Retaining Wall Which Exceeds 1.0 Metre In Height Must Be Set Back From The Nearest Property Line Or Distance Equal To Its Height.
  - Driveway Grades Shall Be 1% - 10% And Compatible With The Approved Grading. Backyard Grades Shall Be 2% - 5%.
  - Driveways Shall Be A Minimum Of 1.0m From Any Tree, Catch Basin Or Above Ground Utility Or Obstruction.
  - Water Service Slopes Are To Be Located In The Grass Portion Of The Front Yard, As Per City Of Vaughan Standard 14.
  - Driveways, Curb Cuts And Diverter Culverts Shall Be Located, Approved And Constructed In Accordance With The Requirements Of The City Engineering Department, Work Report And By-Law 1-88. A Separate Permit Is Required From The City's Engineering/Public Works Department For Curb Cuts And/or Proposed Culverts.
  - Footings Constructed Next To Catch Basin Lead Pipe Or Other Municipal Service Shall Be Inspected Below Lead Pipe Excavation. Footings Must Be Constructed On Undisturbed Soil Or Soil Consolidation Verification Required.
  - If The Proposed Construction Is In An Area Of Fill A Professional Engineer Is To Inspect The Excavation And Certify The Stability And Bearing Capacity Of The Soil Prior To Construction.
  - Prior To Letter Of Credit Release The Owner Shall Submit An As-built Survey Illustrating Both Proposed And As Constructed Grade Elevations. A Storm Water Management Report Authored By A Professional Engineer And/OR Lot Grading Certification By A Professional Engineer Or Ontario Land Surveyor Shall Be Submitted To The City Upon Their Request.
  - Post-Construction Flows From A 5 Year Storm Frequency, Shall Not Exceed The Flow For Preconstruction Conditions. For The Same Storm, Unless It Is Demonstrated To The Satisfaction Of The City That Uncontrolled Flows Will Not Adversely Affect The Existing Drainage Patterns. (These Flows Shall Be Computed Using The Rational Method Only).
  - The Building Shall Be Located On The Building Site Graded So That Water Will Not Accumulate At Or Near The Building And Will Not Adversely Affect Adjacent Properties. OBC 9.14.6.1 (1)
  - Tree Approval Required Where Grade Changes Will Occur That Affect Regulated Areas, Existing Natural Or Artificial Watercourse, Open Channel, Swale Or Ditch Used To Drain Land.
  - Driveway To Be Interlocking Stone Or Patterned Concrete. Asphalt Driveway Is Not Permitted. (Amended For 65m-378)

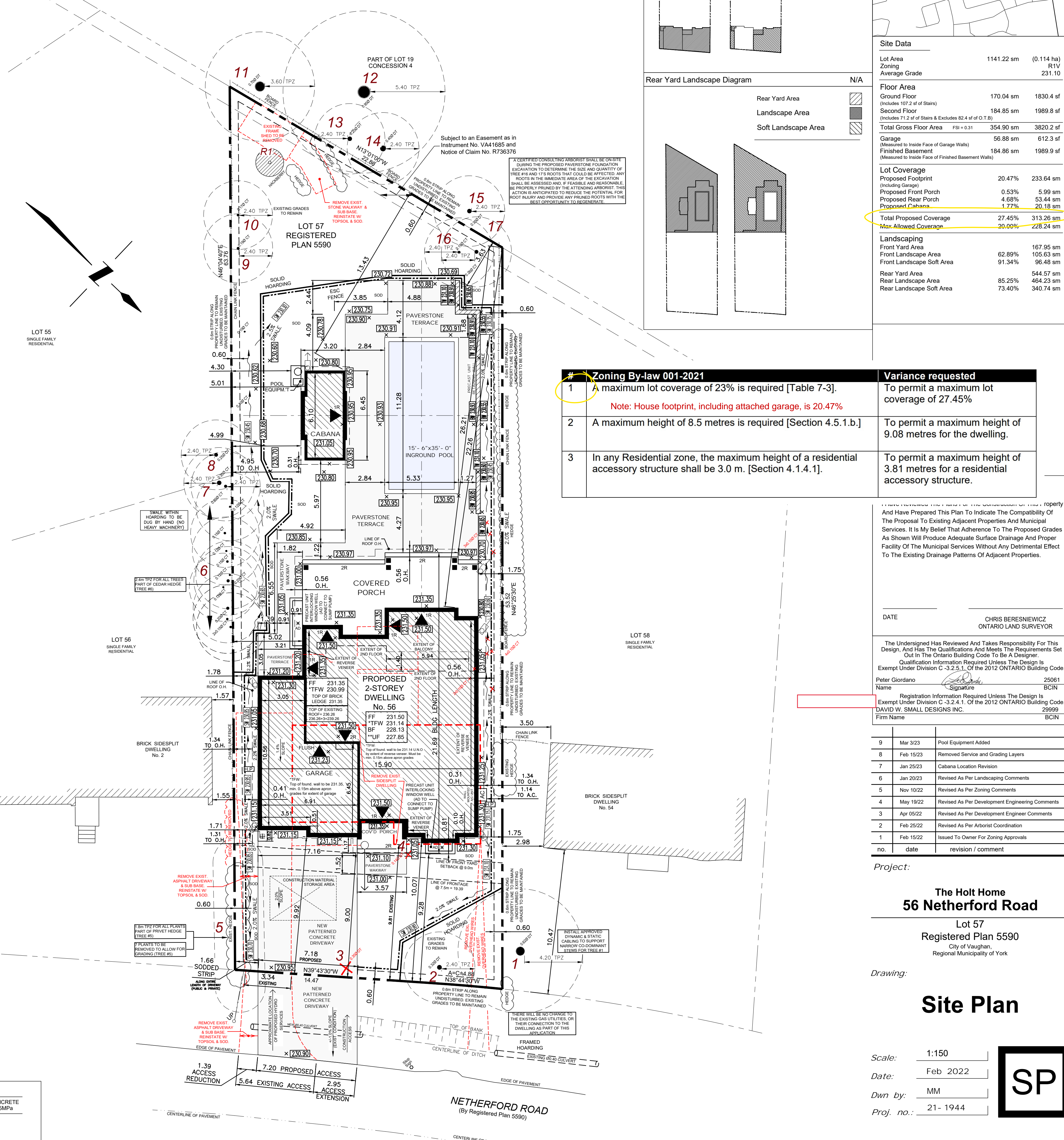
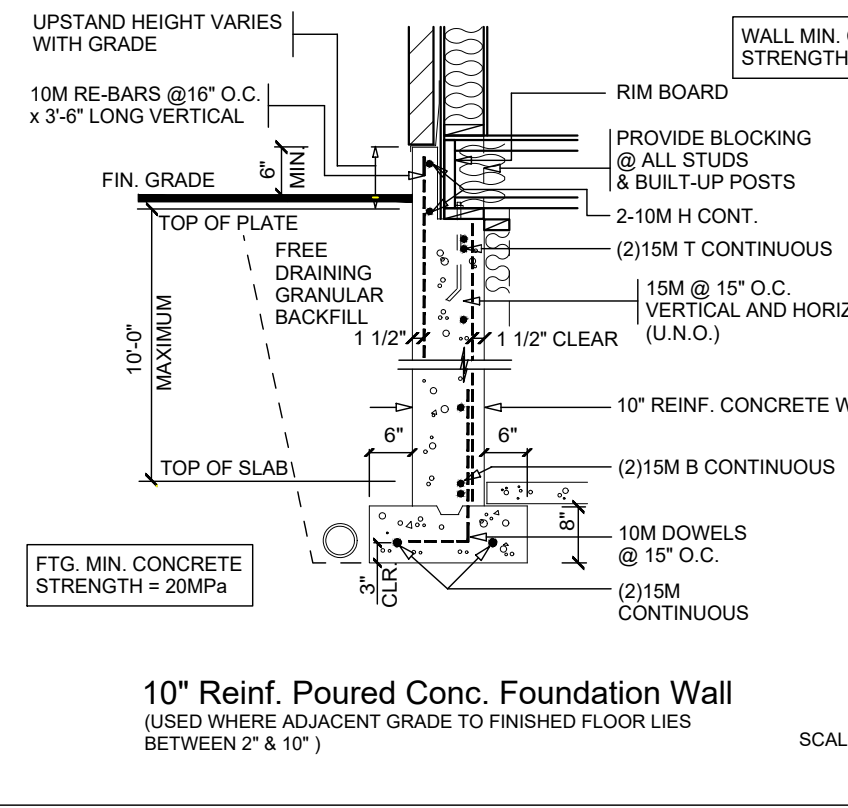
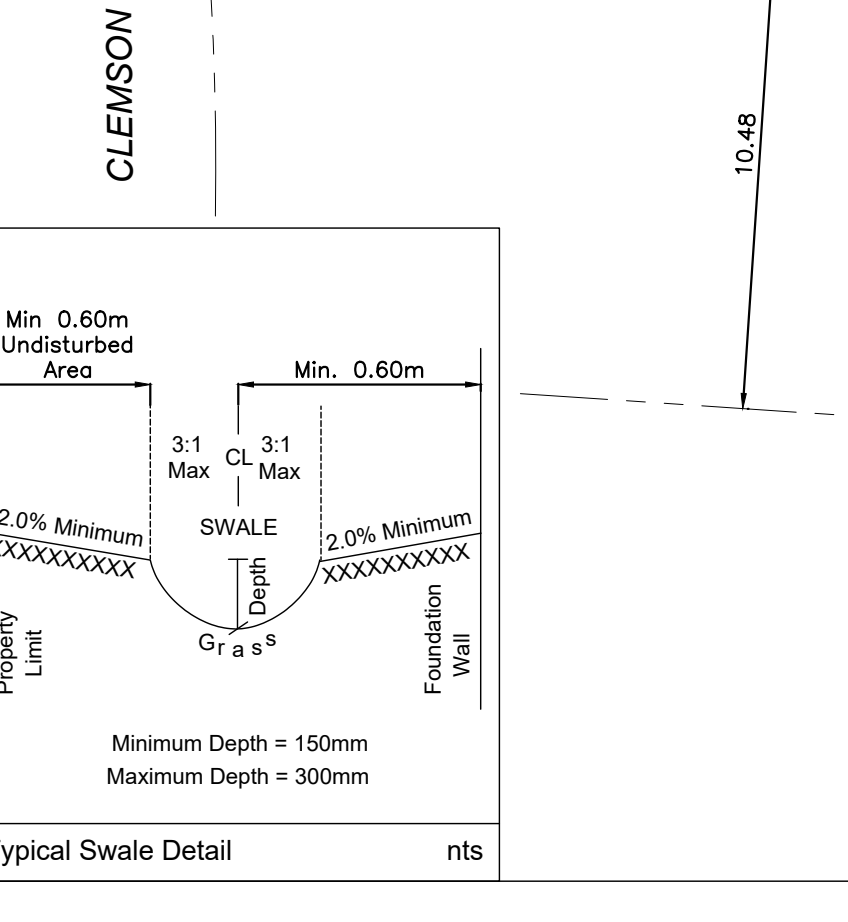
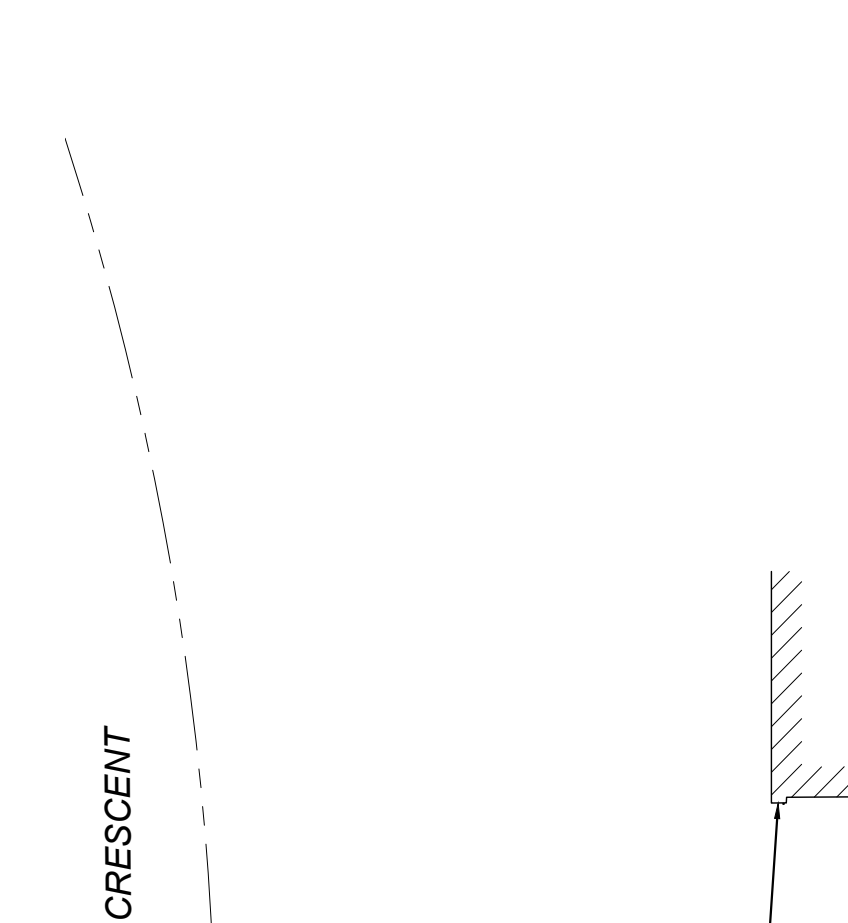
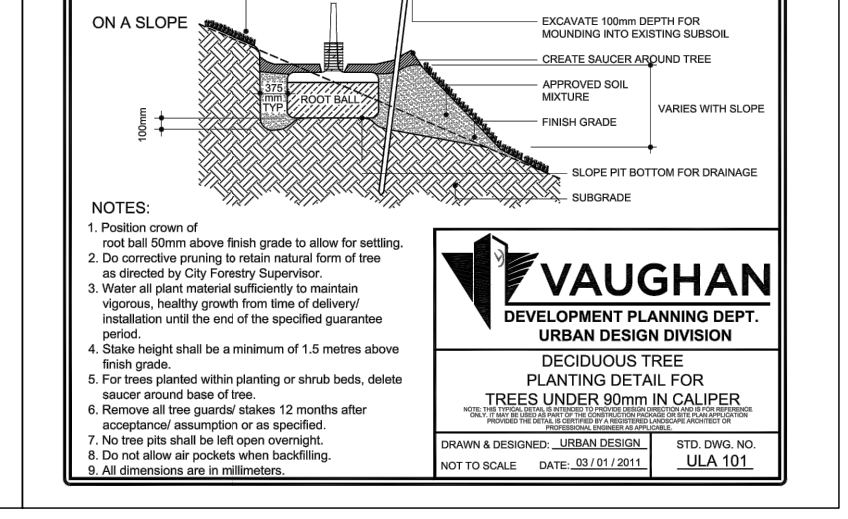
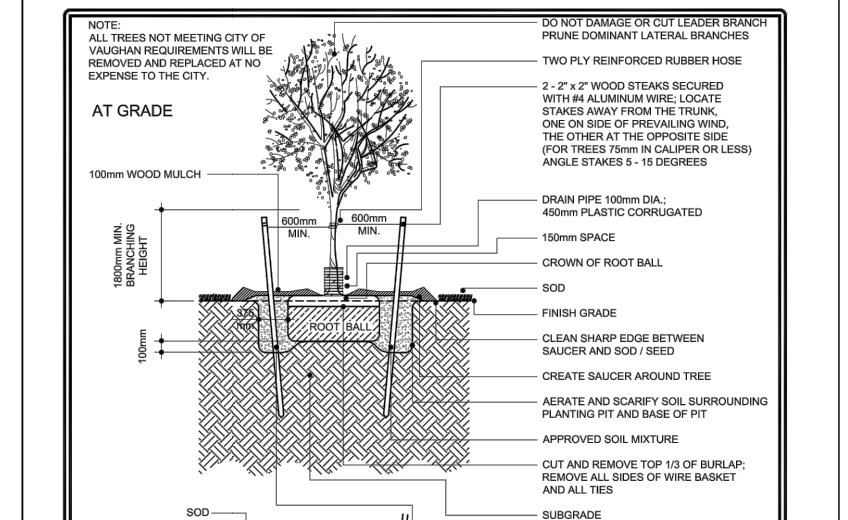
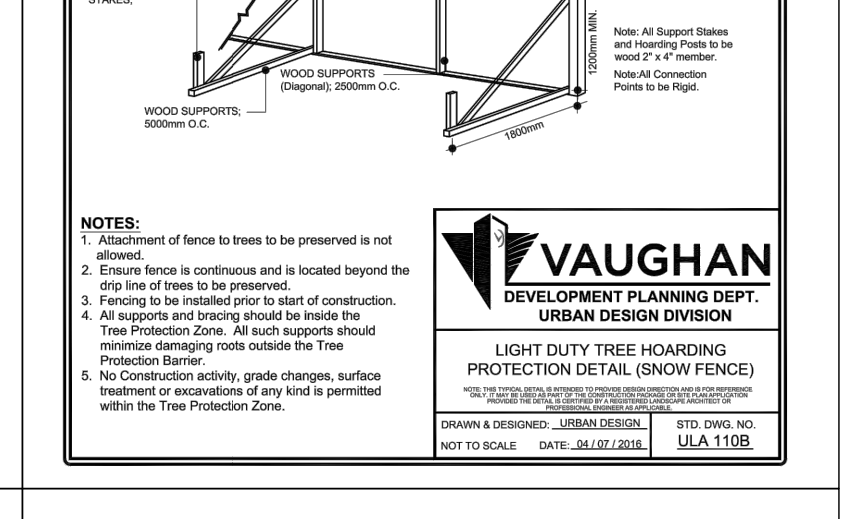
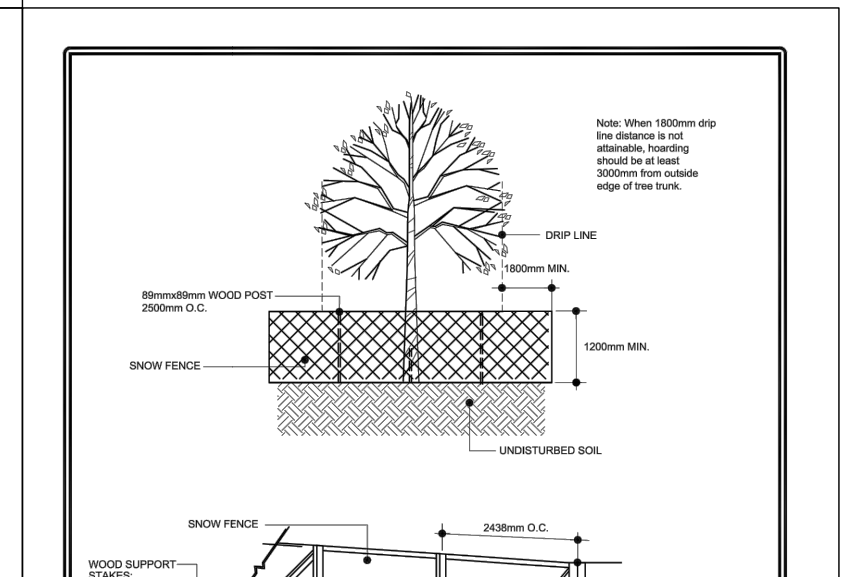

Zoning By-law 001-2021	Variance requested
1. A maximum lot coverage of 23% is required [Table 7-3]. Note: House footprint, including attached garage, is 20.47%	To permit a maximum lot coverage of 27.45%
2. A maximum height of 8.5 metres is required [Section 4.5.1.b.]	To permit a maximum height of 9.08 metres for the dwelling.
3. In any Residential zone, the maximum height of a residential accessory structure shall be 3.0 m. [Section 4.1.4.1].	To permit a maximum height of 3.81 metres for a residential accessory structure.

**Project:** The Holt Home 56 Netherford Road

**Registered Plan 5590**

City of Vaughan, Regional Municipality of York

**Drawing:** SP

**Scale:** 1:150

**Date:** Feb 2022

**Dwn by:** MM

**Prof. no.:** 21-1944

**David Small Designs**

**Elevation Notes**

- ② Prefinished "natural" wood siding to comply with O.N.T. Reg. 332/12 subsection 9.27.6. Lumber-siding and table 9.27.5.4.
- ③ Blocking or furring for the attachment of siding to comply with 9.27.5.2 and 9.27.5.3. and as per manufacturer's specifications
- ③ All stucco to be "DuROCK" EIFS P.U.C.C.S. exterior insulation and finish system CCMC 1296R approved install as per CBC 9.28. and manufacturer's specifications -note use "Polar Bear" by DuROCK for airtightness barrier below stucco in place of Tyvek or equivalent product specified for all walls not clad in stucco
- Note: All over-hangs are 4" inset from stone facing on ground floors (typical)
- Note: Refer to roof plan for all roof slopes and overhang info
- A Stepped footing per OBC 9.15.3.9.
- B Glazing to be tempered glass (if operable window provide opening restrictor) - Comply with OBC 9.8.6.1 (5) and (8)

**Unprotected Openings - Right-Side Elevation**

Limiting Distance	1.55M
Wall Area	1178.2 sf (109.27 sm)
Opening Area Allowed	78.94 sf (7%)
Opening Area Proposed	63 sf (5.35%)

Please Note The Figure For % Openings Allowed Has Been Interpolated Based On O.B.C. Table 9.10.15.4 And Glazed Areas Were Used To Calculate Proposed Openings As Allowed By 9.10.15.4.

**Exterior Colours & Materials Chart**

EXTERIOR FEATURE	PRODUCT DETAILS
NATURAL STONE	Rustic Cedar (Limestone) - Dimensional
BRICK	Cushwa Brick, Stonewall
SMOOTH STONE	Indiana Limestone, Standard Buff Alt. Option: Precast Concrete, Buff Tone
STONE TRIM, SILLS, SURROUNDS & LINTELS	Indiana Limestone, Standard Buff Alt. Option: Precast Concrete, Buff Tone
STUCCO	Benjamin Moore, Silver Satin, OC-26
DARK TRIM, BRACKETS & DECORATIVE VENTS	Benjamin Moore, Black Beauty, 2128-10
ACM PANELS	Alumtech Bond, ACM, Colour: Metallic Grey
ALUMINUM EAVES & FASCIA	Gentek, Black
ASPHALT SHINGLES	Certaainted, Landmark, Colonial Slate
METAL ROOFING	Black
WINDOW FRAMES	Black
FRONT DOOR	Stain Finish: Minwax, Coffee
GARAGE DOOR	Stain Finish: Minwax, Coffee
COVD PORCH POSTS	Benjamin Moore, Black Beauty, 2128-10

NOTE: ALL MATERIALS AND COLOURS ARE SUBJECT TO CLIENT'S PHYSICAL SAMPLE REVIEW TO CONFIRM DESIRED FINISH

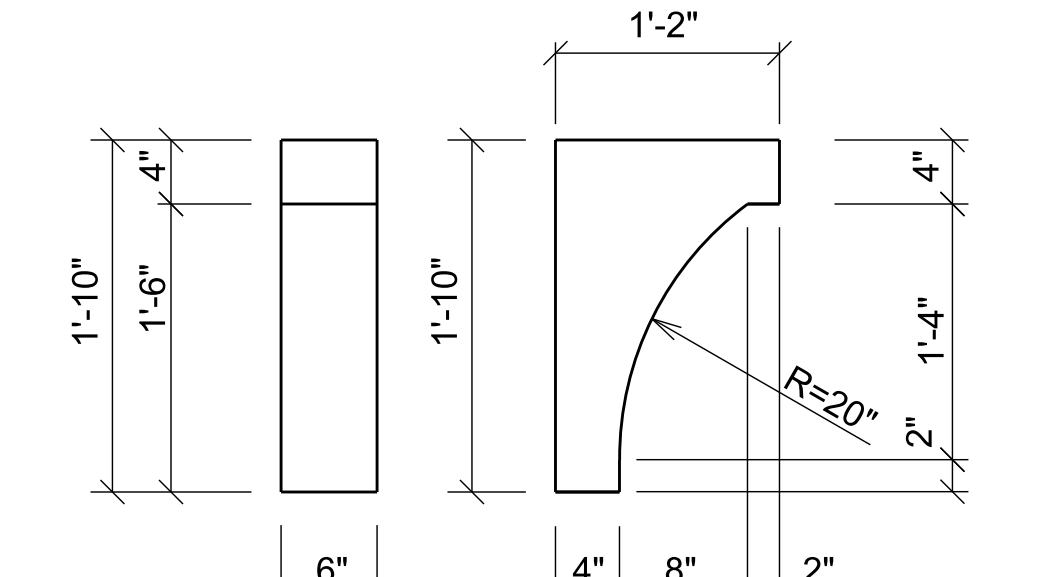

**1 A5 Wood Bracket Detail**

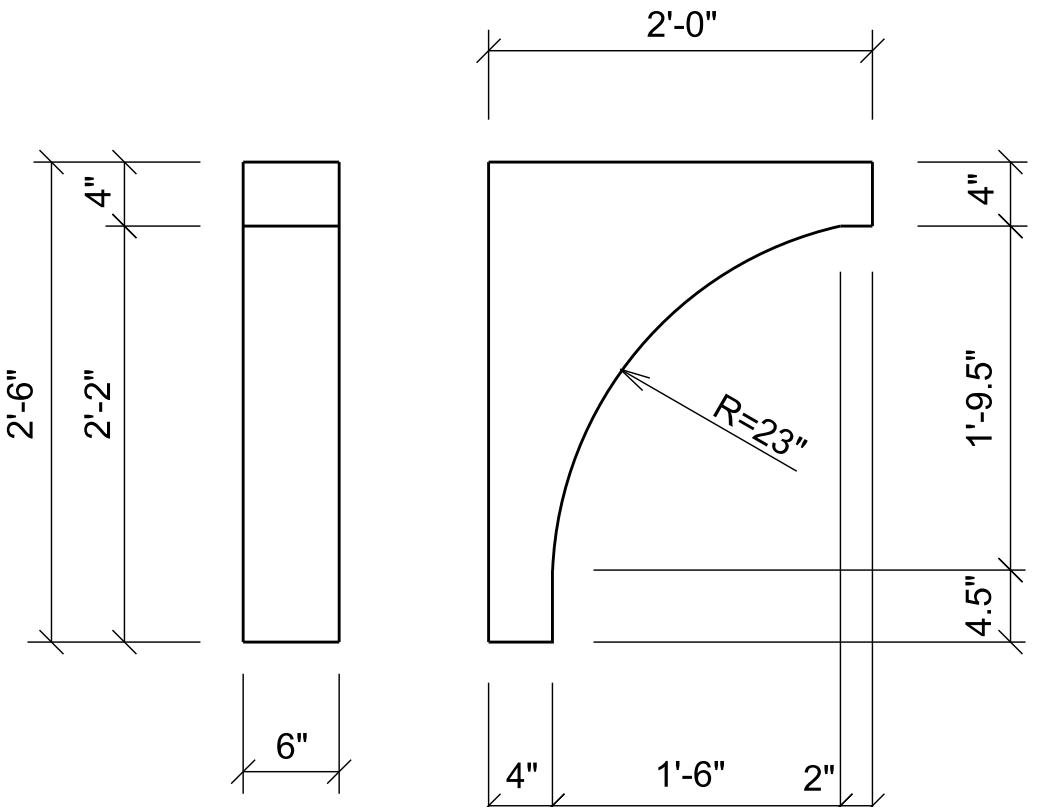

**2 A5 Wood Bracket Detail**

#	Zoning By-law 001-2021	Variance requested
1	A maximum lot coverage of 23% is required [Table 7-3].	To permit a maximum lot coverage of 27.45%
2	A maximum height of 8.5 metres is required [Section 4.5.1.b.]	To permit a maximum height of 9.08 metres for the dwelling.
3	In any Residential zone, the maximum height of a residential accessory structure shall be 3.0 m. [Section 4.1.4.1].	To permit a maximum height of 3.81 metres for a residential accessory structure.

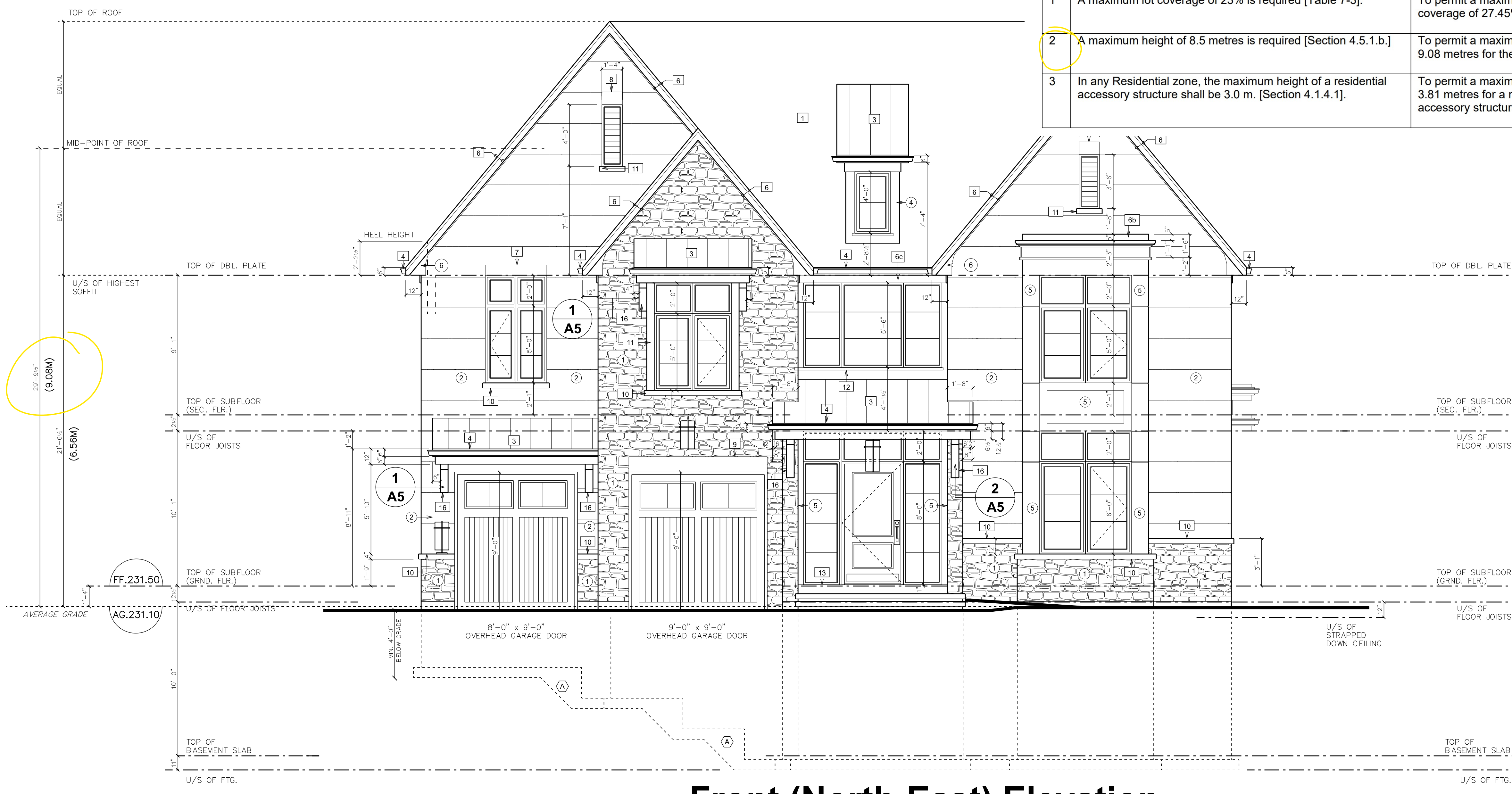

**Front (North-East) Elevation**

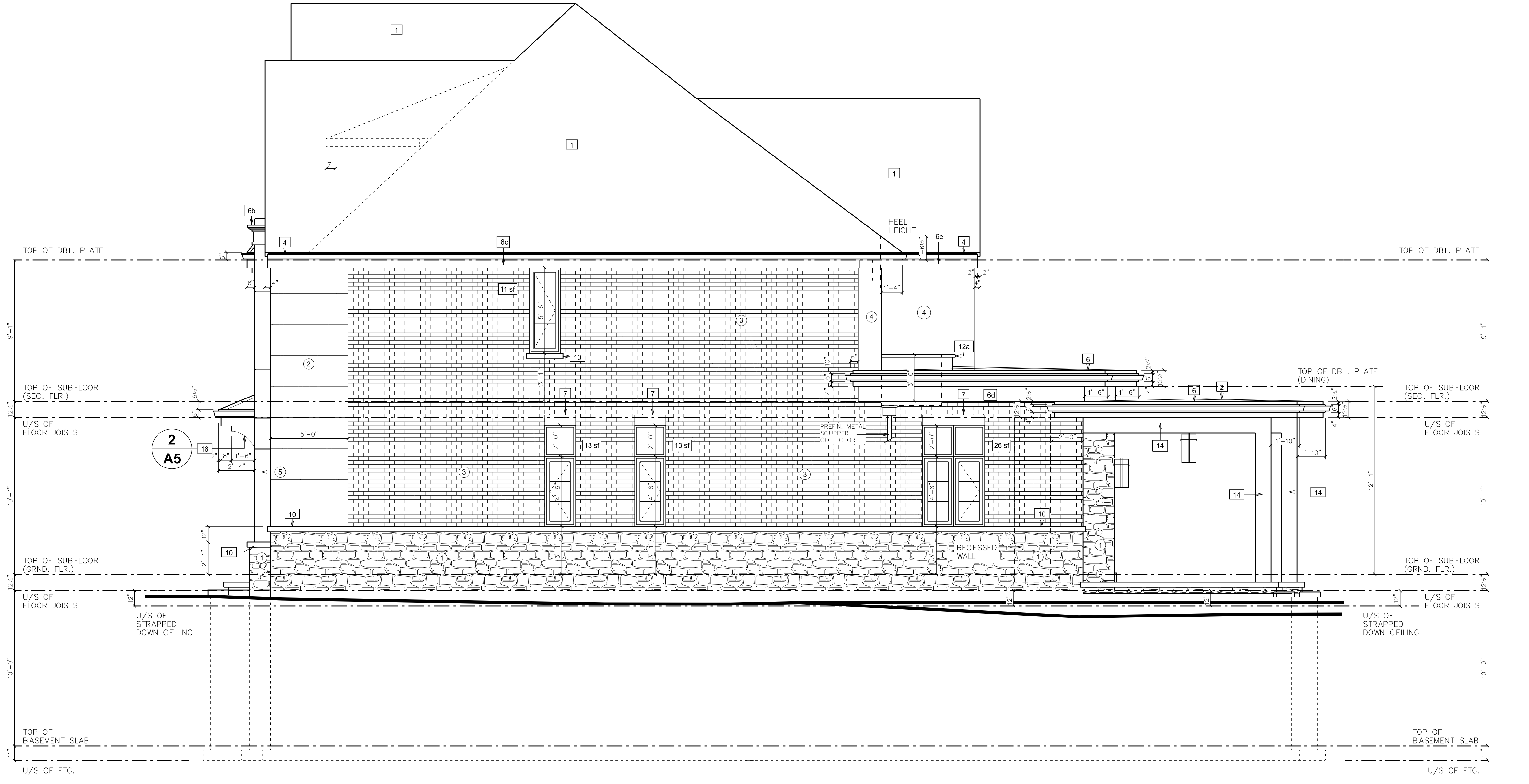

**Right-Side (North-West) Elevation**

**Drawing Legend**

- 1.0 Materials**
- ① Natural Stone
  - ② Cut Stone
  - ③ Brick Veneer
  - ④ Pigmented Epoxy Stucco
  - ⑤ ACM Panel
  - ⑥ Prefinished Metal Fascia
- 2.0 Roofing**
- ① 40 Year Asphalt Shingles
  - ② 2-Ply Torched On Rubber Membrane Roof Sloped To 2% To Outside Edge On 1/2" Plywood Roof Sheathing On Roof Trusses/Joists
  - ③ Raised Seam Prefinished Metal Roofing
- 3.0 Trim, Cornice, Moulding, & Gutter Notes**
- ④ 6" Square Bent Prefinished Aluminum Eaves Trough on 6" Prefinished Aluminum Fascia
  - ⑤ 6" Square Bent Prefinished Aluminum Eaves Trough on 6" Prefinished Aluminum Fascia
  - ⑥ 6" Prefinished Aluminum Fascia w/ 2" top Edge reveal
  - ⑥a 2" Aluminum Trim w/ 1" Projection
  - ⑥b Sloped Aluminum Cap 2% w/ drip edge
  - ⑥c 6" Prefinished Wood Trim
  - ⑥d 12" Prefinished Wood Trim
  - ⑥e 12" Stucco Covered Trim
  - ⑦ 8" Cut Stone Lintel
  - ⑧ 10" Cut Stone Lintel
  - ⑧a 10" Stucco Covered Lintel
  - ⑨ 12" Cut Stone Lintel
  - ⑩ 4" Cut Stone Sill w/ 2" Projection
  - ⑩a 6" Cut Stone Surround
  - ⑩b 2" Aluminum Sill w/ 2" Projection
  - ⑩c 2" Aluminum Coping w/ 2" Projection
  - ⑩d 7" Cut Stone Step-Up
- 4.0 Railing & Post**
- ⑭ 12"x12" Crezon Clad Site-Painted Wood Post
  - ⑮ Frameless Tempered Glass Panels Min. 42" Above Fin. Decking - Contractor To Provide Shop Drawing To Inspector Prior To Installation To Ensure They Meet All Aspect Of OBC 9.8. & SB-13 Of The Supplement
  - ⑯ Site-Painted Wood Bracket

The undersigned has reviewed and takes responsibility for this design, and has the qualifications and meets the requirements set out in the Ontario building code for a designer. Qualification information required unless the design is exempt under Division C - 3.2.6.1. of the 2012 Ontario Building Code.

Peter Giordano 2061  
Name Signature  
Registration information required unless the design is exempt under Division C - 3.2.4.1. of the 2012 Ontario Building Code.  
David W. Small Designs Inc. 2999  
Firm Name BCIN

no.	date	revision / comment
2	May 16/22	Revised As Per Zoning Comments
1	Feb 15/22	Issued To Owner For Zoning Approval

Project: **The Holt Home**  
**56 Netherford Road**  
Lot 57  
Registered Plan 5590  
City of Vaughan,  
Regional Municipality of York

**Front & Right-Side Elevations**

Scale: 1/4" = 1'-0"  
Date: Feb 2022  
Dwn by: C/J/NM  
Proj. no.: 21-1944

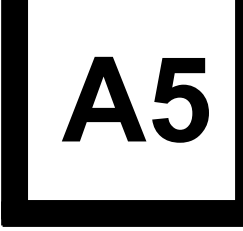

**David Small Designs**

**Elevation Notes**

- ② Prefinished 'natural' wood siding to comply with ONT. Reg. 332/12 subsection 9.27.6. Lumber-siding and table 9.27.5.4.
- ③ Blocking or furring for the attachment of siding to comply with 9.27.5.2 and 9.27.5.3, and as per manufacturer's specifications.
- ③ All stucco to be 'DuROCK' EIFS P.U.C.C.S. exterior insulation and finish system CMC 1296R approved install as per OBC 9.28 and manufacturer's specifications - note use 'Polar Bear' by DuROCK for air/moisture barrier below stucco in place of Tyvek or equivalent product specified for all walls not clad in stucco.
- Note: All over-hangs are 4" inset from stone facing on ground floors (typical)
- Note: Refer to roof plan for all roof slopes and overhang info
- A Stepped footing per OBC 9.15.3.9.
- B Glazing to be tempered glass (if operable window provide opening restrictor) - Comply with OBC 9.8.8.1 (5) and (5)

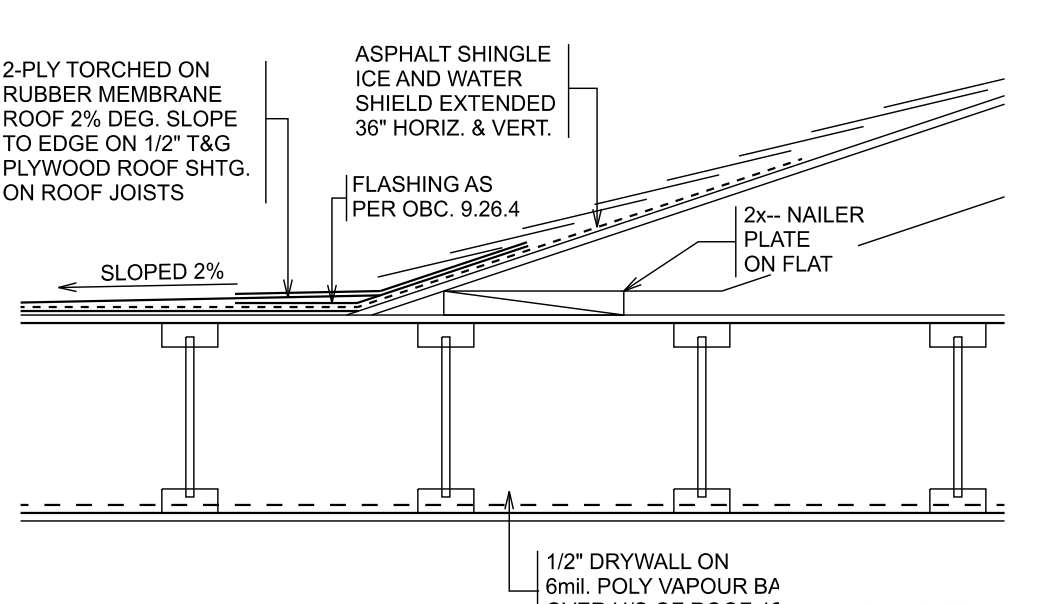

**1 C1 Slope Roof Onto Flat Roof Conc**

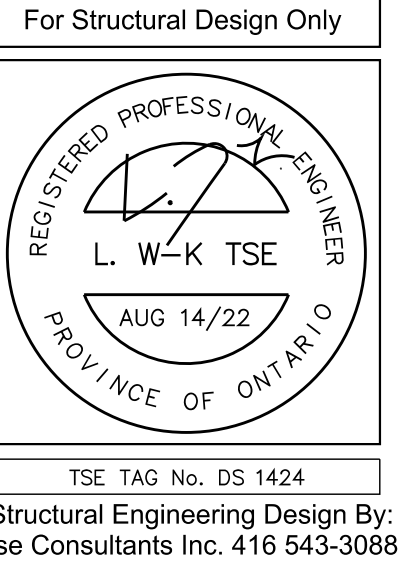

TSE TAC No. DS 1424  
Structural Engineering Design By:  
Tse Consultants Inc. 416 543-3088

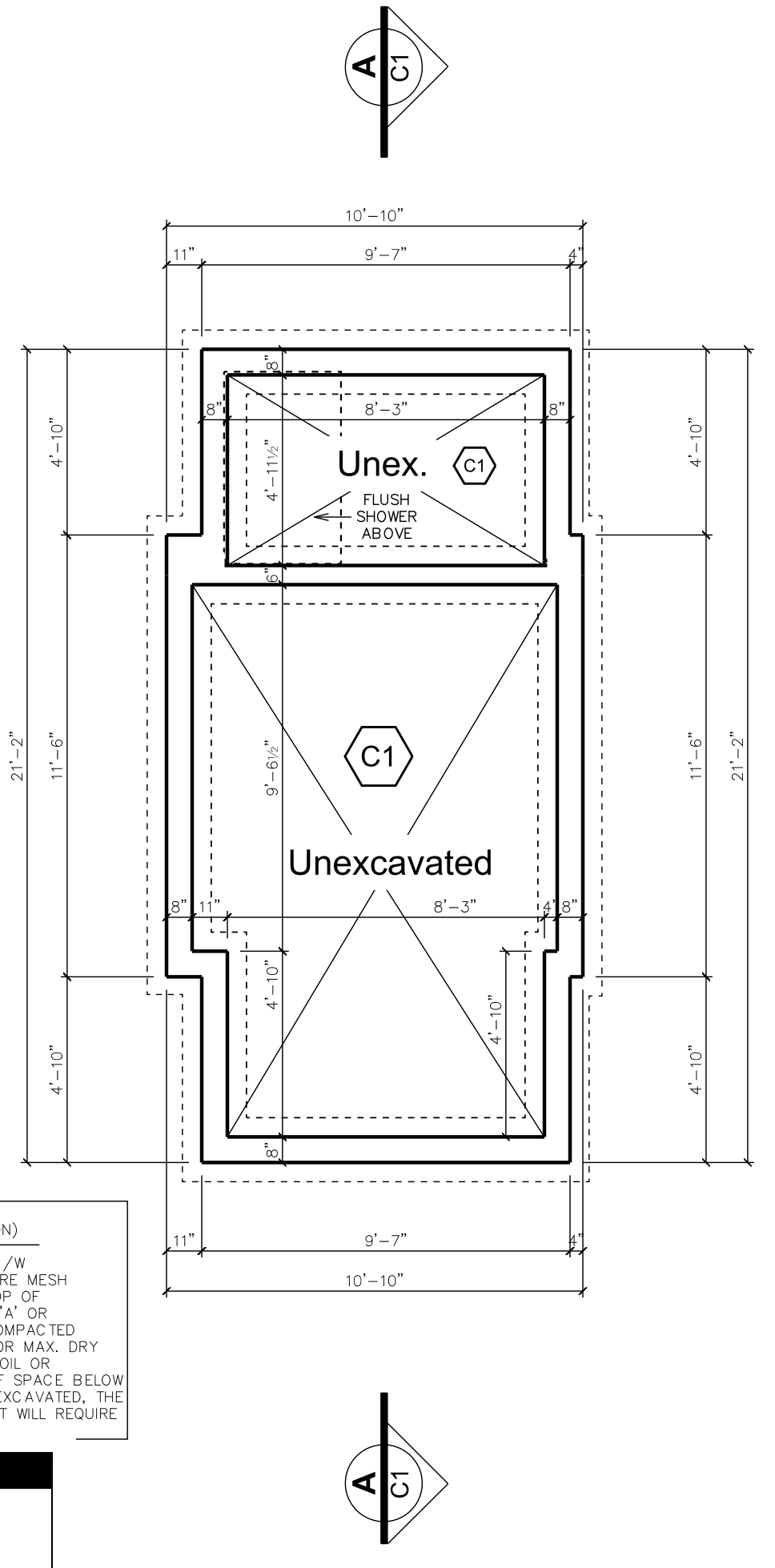

**C1** TYPICAL PORCH SLAB (SLAB ON GRADE CONDITION)  
4" R.C. SLAB ON GRADE 1/2" POLYMER SHEET REINFORCED WIRE MESH PLACED 2" DOWN FROM TOP OF SLAB OVER 4" GRANULAR FILL OR EQUAL GRAVEL ON SOLID COMPACTED TO USE STANDARD PROCTOR MAX. DRY DENSITY ON UNDISTURBED SOIL OR ENGINEERED FILL - NOTE: IF SPACE BELOW IS CHANGED TO BECOME EXCAVATED, THE SLAB & WALL REQUIREMENT WILL REQUIRE

**Foundation Plan**

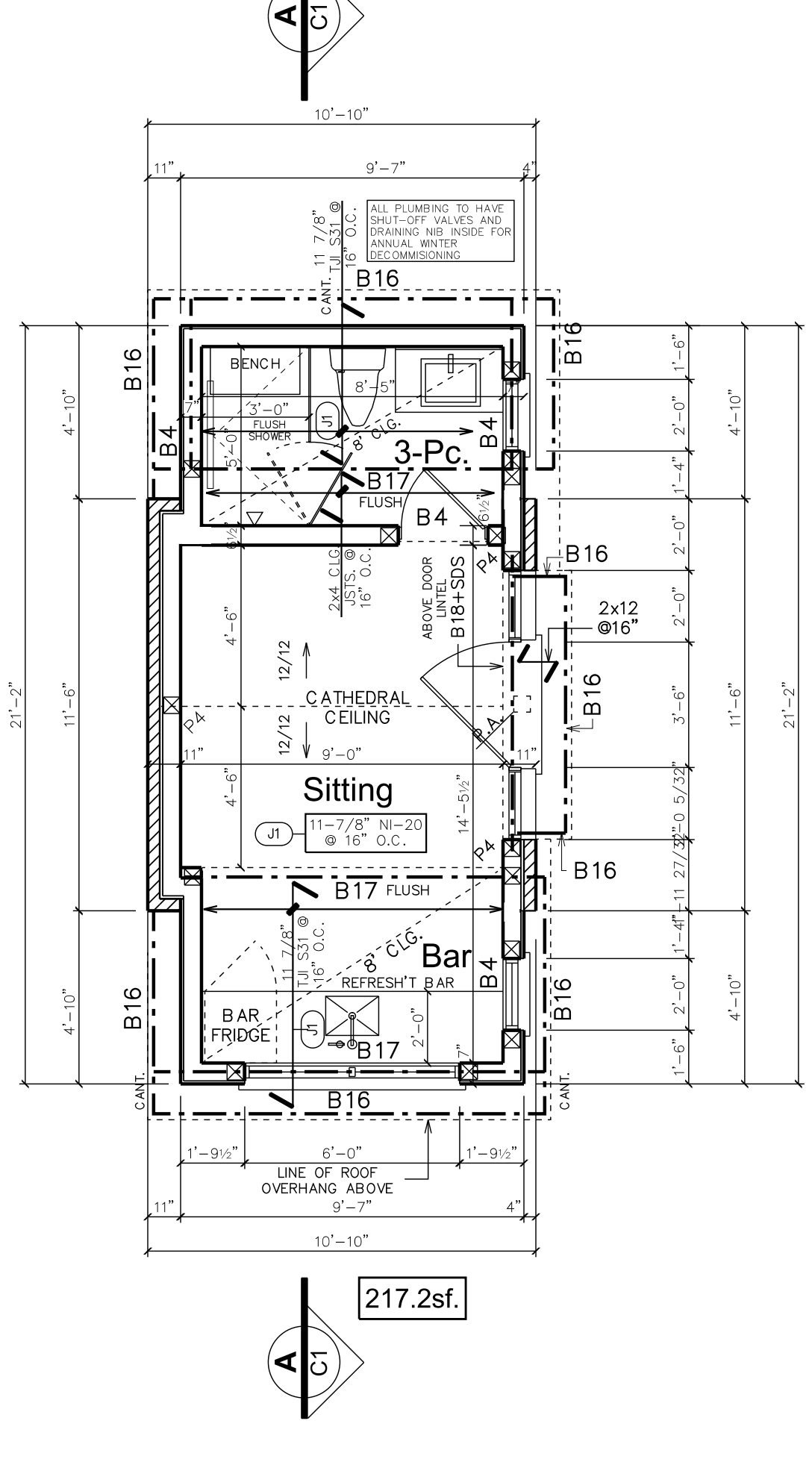

**Ground Floor Plan**

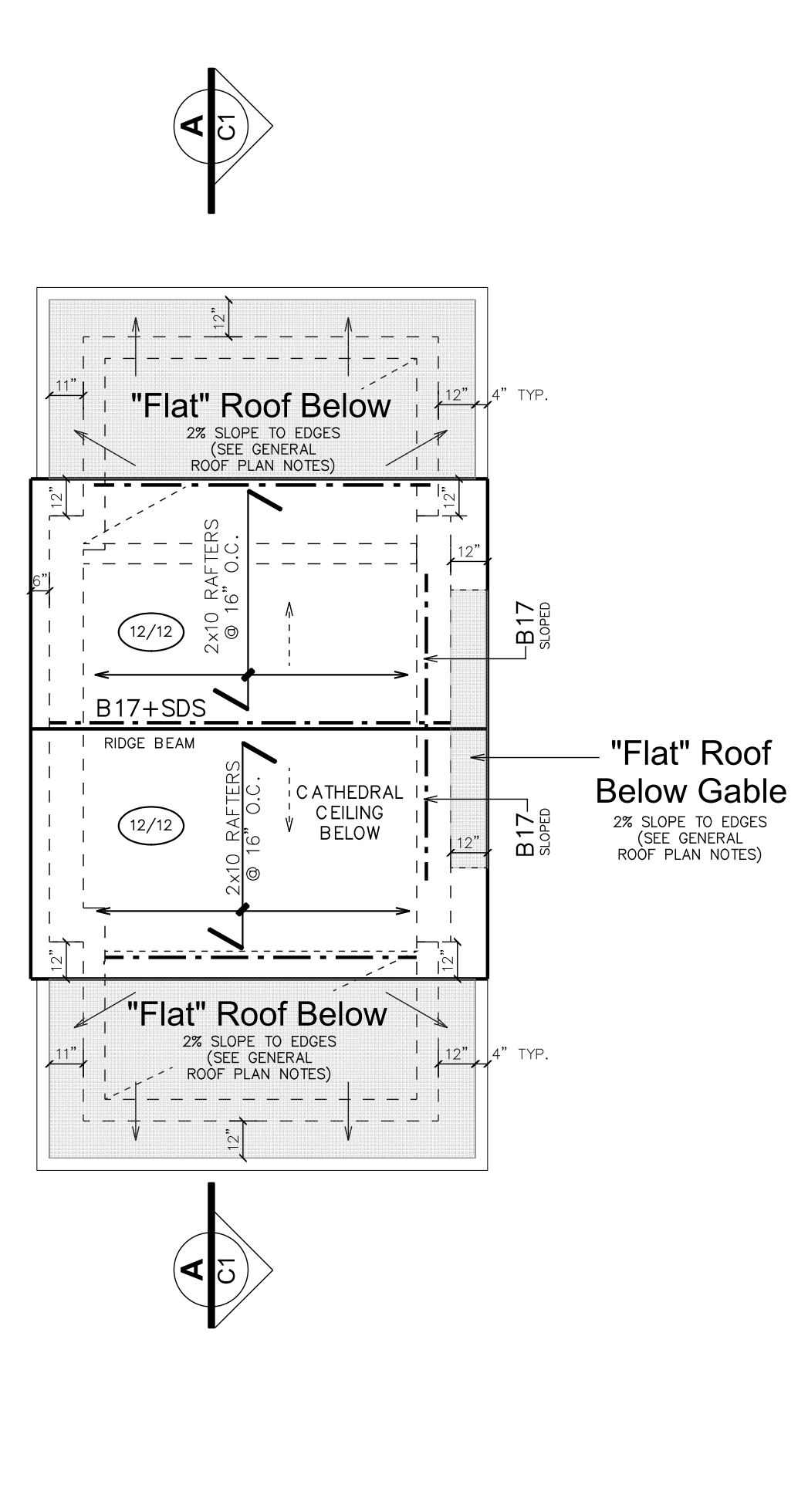

**Roof Plan**

**Exterior Colours & Materials Chart**

EXTERIOR FEATURE	PRODUCT
NATURAL STONE	Rustic Cedar Dimensional
BRICK	Cushwa Brick, Stonewall
SMOOTH STONE	Indiana Limestone, Standard Buff Alt. Option: Precast Concrete, Buff Tone
STONE TRIM, SILLS, SURROUNDS & LINTELS	Indiana Limestone, Standard Buff Alt. Option: Precast Concrete, Buff Tone
STUCCO	Benjamin Moore, Silver Satin, OC-26
DARK TRIM, BRACKETS & DECORATIVE VENTS	Benjamin Moore, Black Beauty, 2128-10
ACM PANELS	Alumtech Bond, ACM, Colour: Metallic Grey
ALUMINUM EAVES & FASCIA	Gentek, Black
ASPHALT SHINGLES	Certaainted, Landmark, Colonial Slate
METAL ROOFING	Black
WINDOW FRAMES	Black
FRONT DOOR	Stain Finish: Minwax, Coffee
GARAGE DOOR	Stain Finish: Minwax, Coffee
COVD PORCH POSTS	Benjamin Moore, Black Beauty, 2128-10

NOTE: ALL MATERIALS AND COLOURS ARE SUBJECT TO CLIENT'S PHYSICAL SAMPLE REVIEW TO CONFIRM DESIRED FINISH

#	Zoning By-law 001-2021	Variance requested
1	A maximum lot coverage of 23% is required [Table 7-3].	To permit a maximum lot coverage of 27.45%
2	A maximum height of 8.5 metres is required [Section 4.5.1.b.]	To permit a maximum height of 9.08 metres for the dwelling.
3	In any Residential zone, the maximum height of a residential accessory structure shall be 3.0 m. [Section 4.1.4.1].	To permit a maximum height of 3.81 metres for a residential accessory structure.

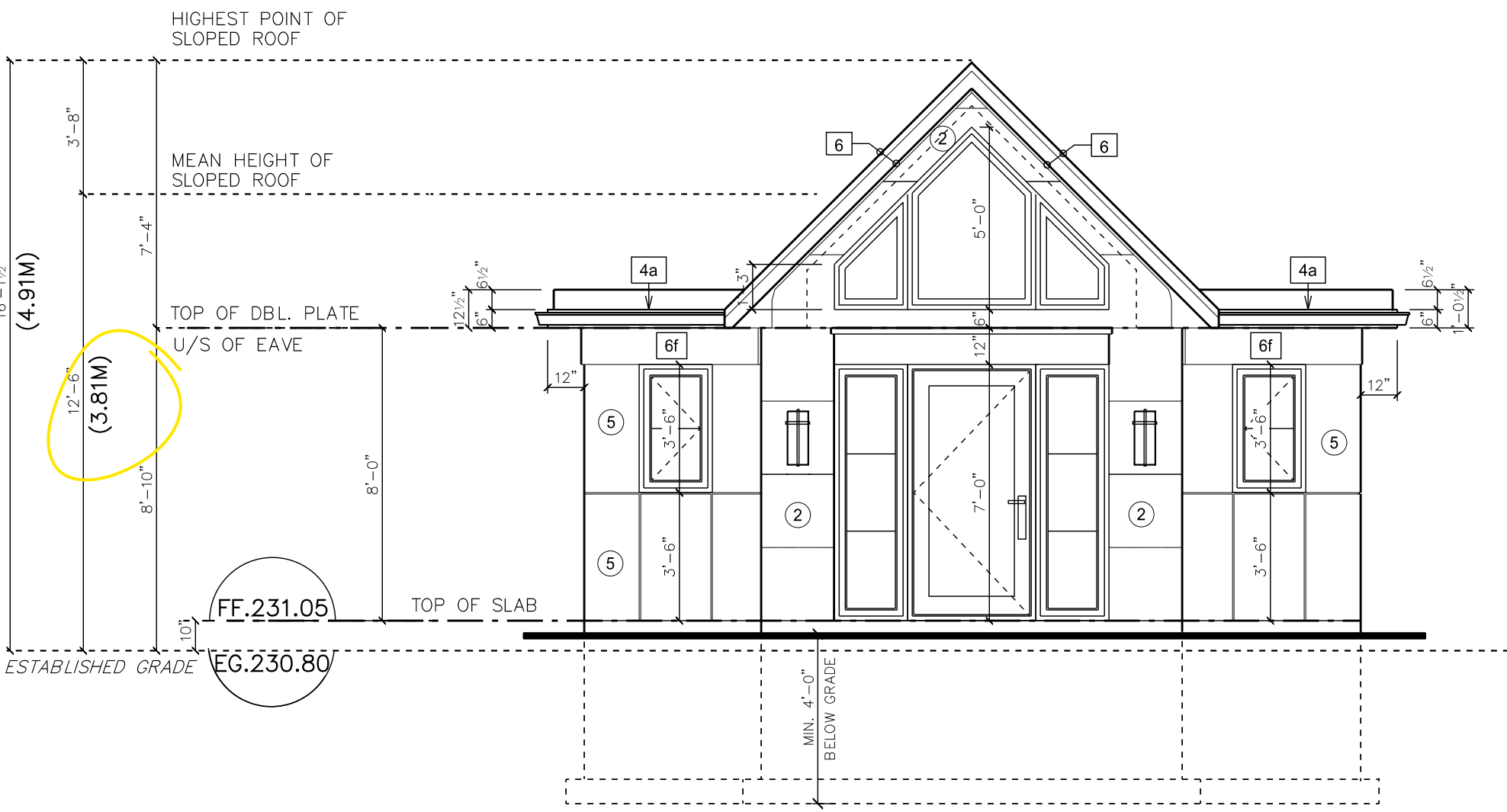

**Front (North-West) Elevation**

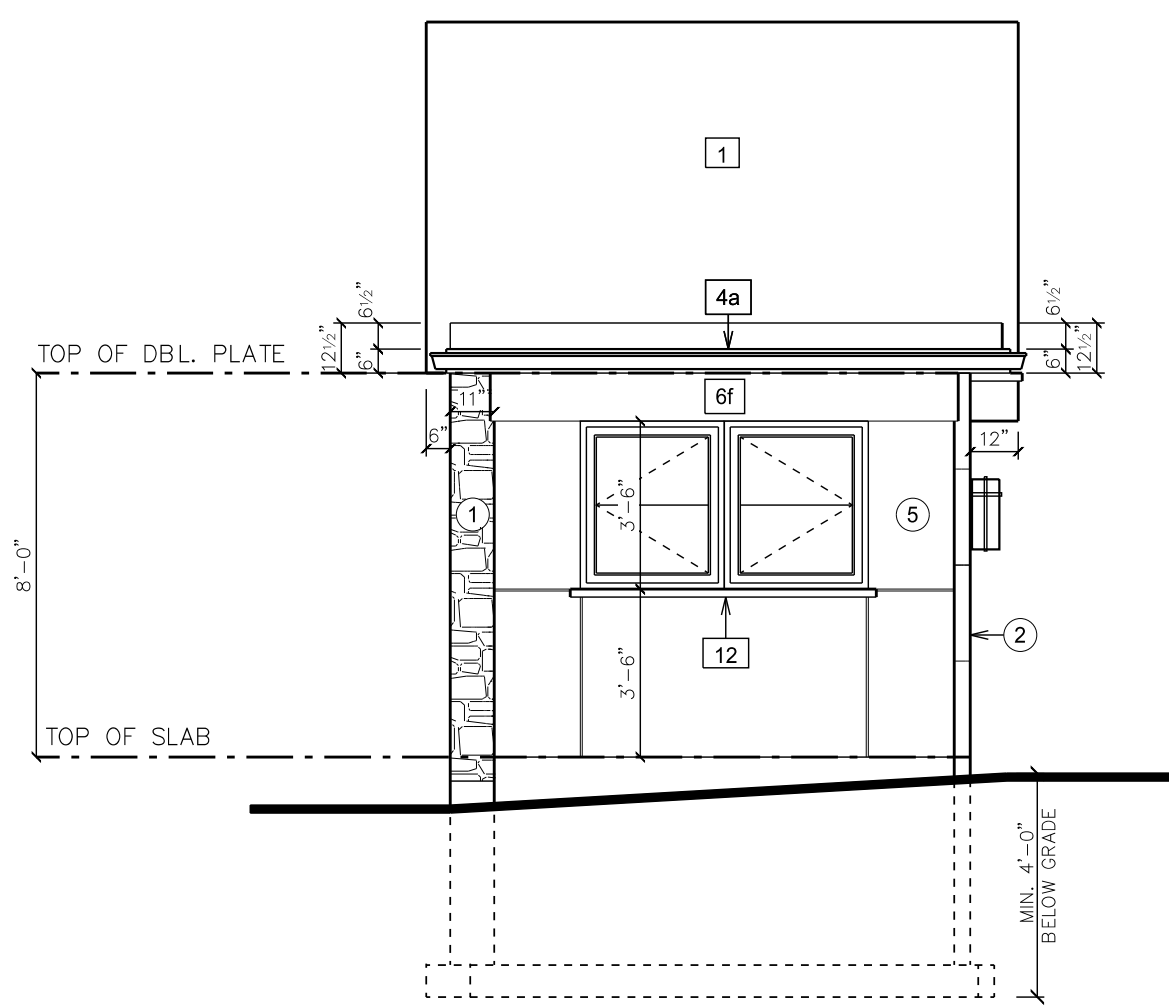

**Right-Side (South-West) Elevation**

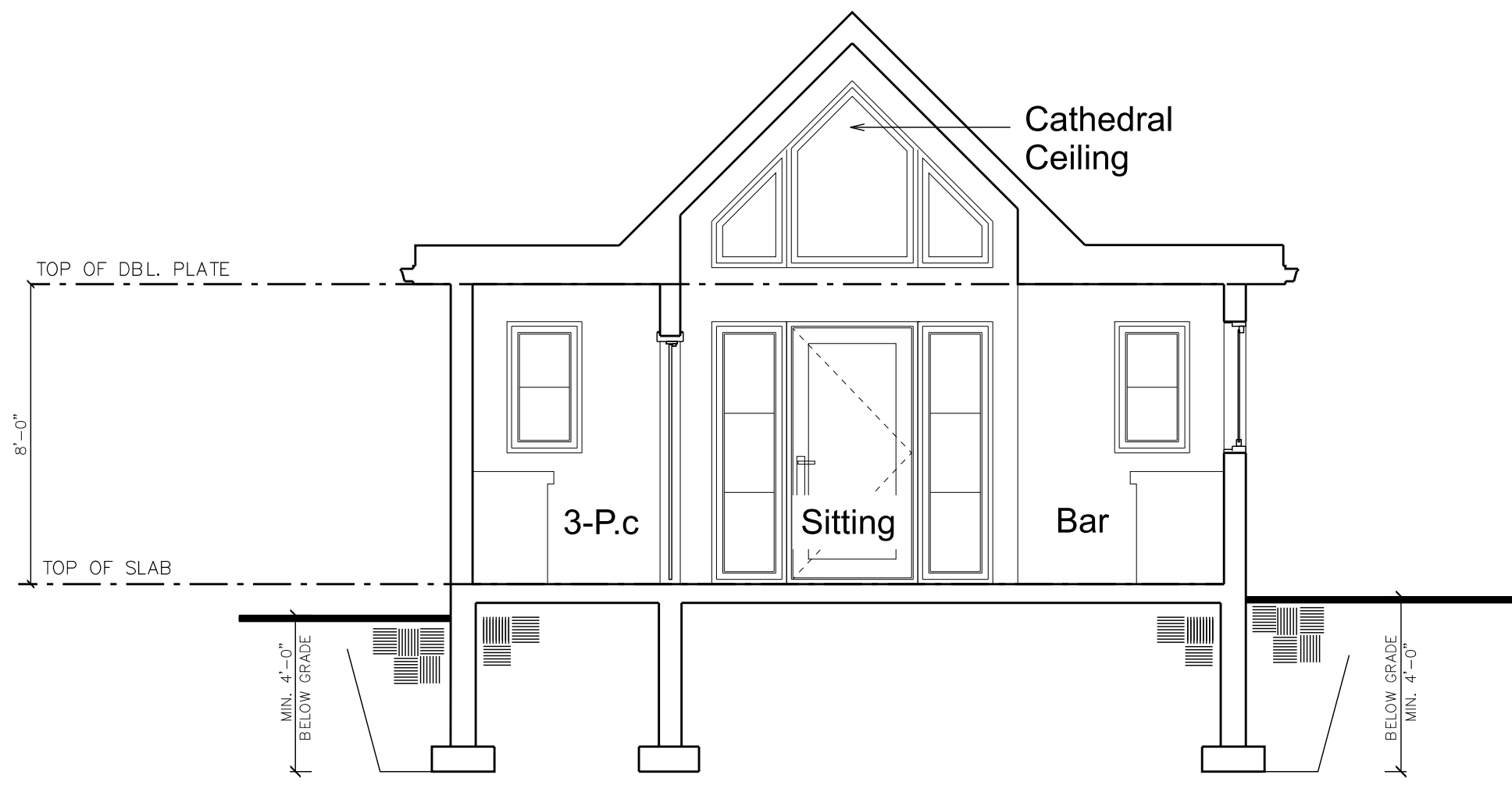

**Section A-A**

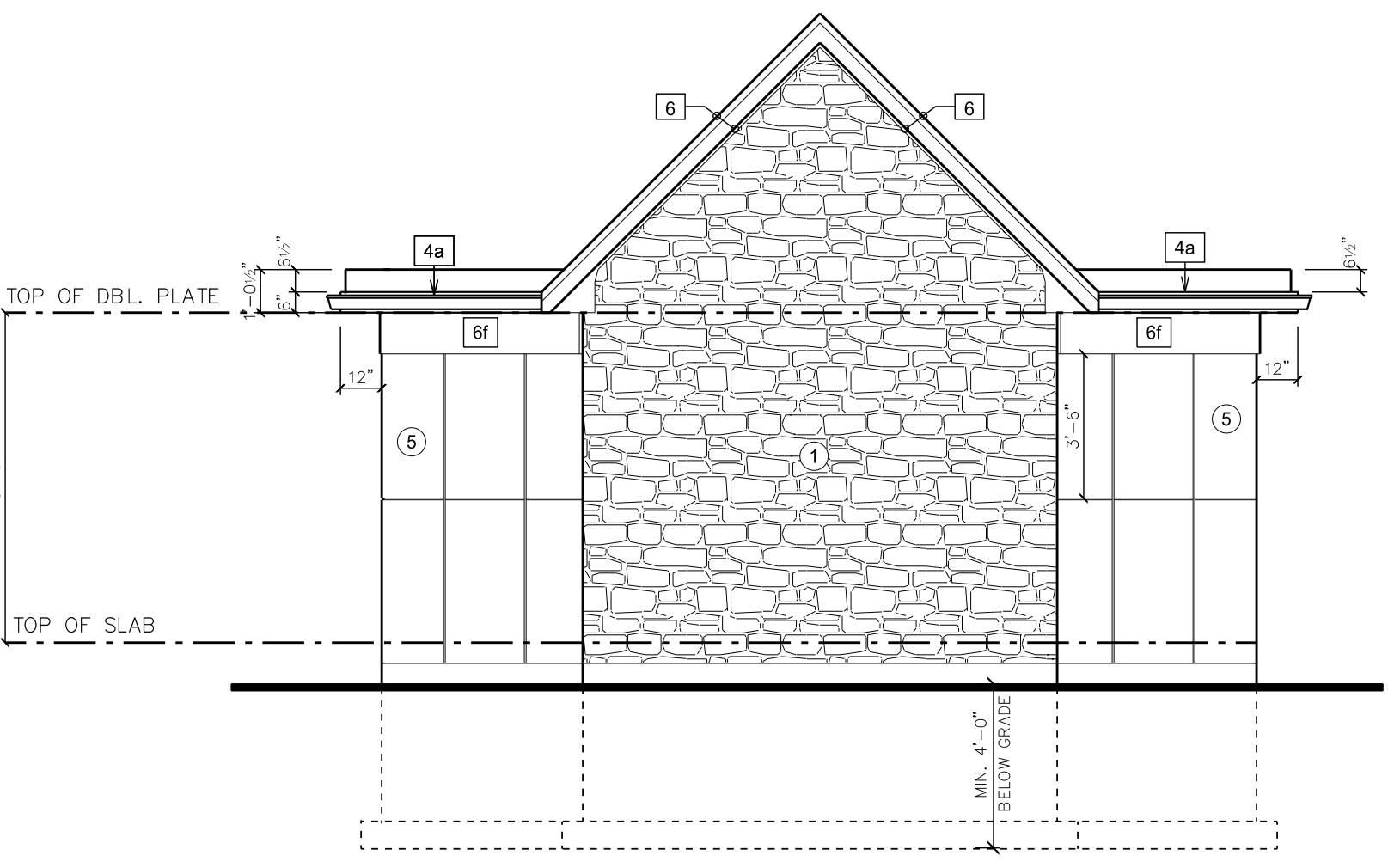

**Rear (South-East) Elevation**

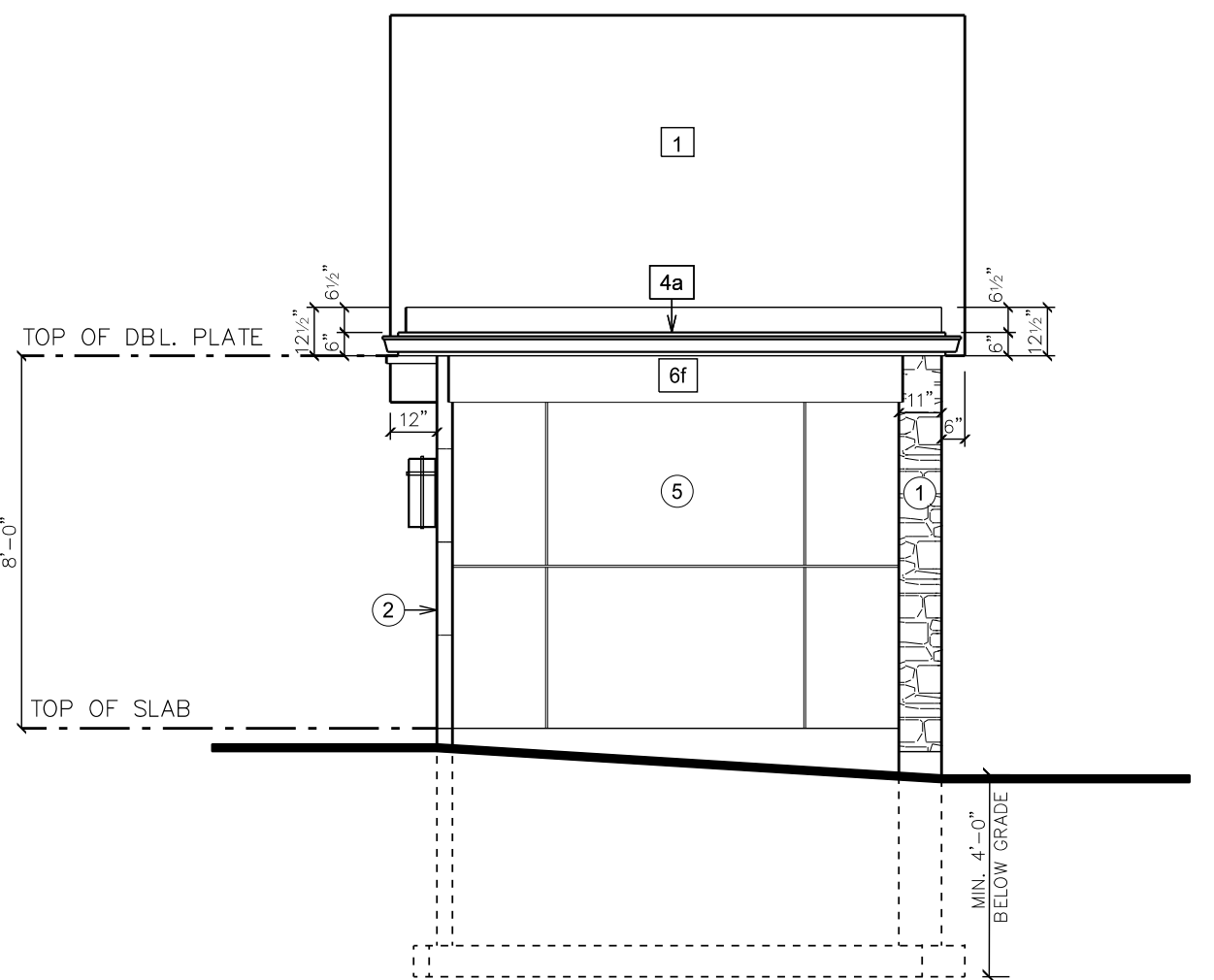

**Left-Side (North-East) Elevation**

**Drawing Legend**

- 1.0 Materials**
  - ① Natural Stone
  - ② Cut Stone
  - ⑤ ACM Panel
- 2.0 Roofing**
  - 1 40 Year Asphalt Shingles
  - 2 2-Ply Torched On Rubber Membrane Roof Sloped To 2% To Outside Edge On 1/2" Plywood Roof Sheathing On Roof Trusses/Joists
- 3.0 Trim, Cornice, Moulding, & Gutter Notes**
  - 4a 12" Wide Prefinished Aluminum Fascia w/ Starter Strip & Drip Edge 1"x12" Base Fascia Board 1"x6" Flat Stock 5" Square Bent Prefinished Aluminum Eaves Trough
  - 6r 12" Flat Aluminum Trim
  - 12 2" Aluminum Sill w/ 2" Projection

The undersigned has reviewed and takes responsibility for this design, and has the qualifications and meets the requirements set out in the Ontario Building Code to be a designer.  
Qualification Information required unless the design is exempt under Division C - 3.2.6.1. of the 2012 Ontario Building Code.  
Peter Giordano  
Name: [Signature] 2981  
Registration Information required unless the design is exempt under Division C - 3.2.4.1. of the 2012 Ontario Building Code.  
David W. Small Designs Inc. 2999  
Firm Name: [Signature] 3074

no.	date	revision / comment
3	Mar 22/23	Colours Revisions
2	Aug 19/22	Coordination With PEng - TSE Consultants
1	Feb 15/22	Issued To Client For Zoning Approvals

Project:  
**The Holt Home**  
**56 Netherford Road**  
Lot 57  
Registered Plan 5590  
City of Vaughan,  
Regional Municipality of York

**Cabana**  
Scale: 1/4" = 1'-0"  
Date: Feb 2022  
Dwn by: C/J/NM  
Proj. no.: 21-1944

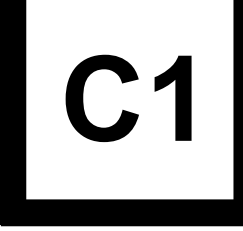

**David Small Designs**

**SCHEDULE B: STAFF & AGENCY COMMENTS**

<b>DEPT/AGENCY</b>	<b>Circulated</b>	<b>Comments Received</b>	<b>Conditions</b>	<b>Nature of Comments</b>
TRCA *Schedule B	X			No Comments Received to Date
Ministry of Transportation (MTO) *Schedule B				No Comments Received to Date
Region of York *Schedule B	X			No Comments Received to Date
Alectra *Schedule B	X	X		General Comments
Bell Canada *Schedule B	X			No Comments Received to Date
YRDSB *Schedule B				
YCDSB *Schedule B				
CN Rail *Schedule B				
CP Rail *Schedule B				
TransCanada Pipeline *Schedule B	X			No Comments Received to Date
Metrolinx *Schedule B				
Propane Operator *Schedule B				
Development Planning	X	X		Recommend Approval/no conditions
Building Standards (Zoning)	X	X		General Comments

**SCHEDULE C: PUBLIC & APPLICANT CORRESPONDENCE**

None

**Date:** March 16<sup>th</sup> 2023

**Attention:** **Christine Vigneault**

**RE:** Request for Comments

**File No.:** **A026-23**

**Related Files:**

**Applicant** Linda Holt

**Location** 56 Netherford Road



Discover the possibilities

### COMMENTS:

- We have reviewed the proposed Variance Application and have no comments or objections to its approval.
- We have reviewed the proposed Variance Application and have no objections to its approval, subject to the following comments (attached below).
- We have reviewed the proposed Variance Application and have the following concerns (attached below).

Alectra Utilities (formerly PowerStream) has received and reviewed the proposed Variance Application. This review, however, does not imply any approval of the project or plan.

All proposed billboards, signs, and other structures associated with the project or plan must maintain minimum clearances to the existing overhead or underground electrical distribution system as specified by the applicable standards, codes and acts referenced.

In the event that construction commences, and the clearance between any component of the work/structure and the adjacent existing overhead and underground electrical distribution system violates the Occupational Health and Safety Act, the customer will be responsible for 100% of the costs associated with Alectra making the work area safe. All construction work will be required to stop until the safe limits of approach can be established.

In the event construction is completed, and the clearance between the constructed structure and the adjacent existing overhead and underground electrical distribution system violates the any of applicable standards, acts or codes referenced, the customer will be responsible for 100% of Alectra's cost for any relocation work.

### References:

- Ontario Electrical Safety Code, latest edition (Clearance of Conductors from Buildings)
- Ontario Health and Safety Act, latest edition (Construction Protection)
- Ontario Building Code, latest edition (Clearance to Buildings)
- PowerStream (Construction Standard 03-1, 03-4), attached
- Canadian Standards Association, latest edition (Basic Clearances)

If more information is required, please contact either of the following:

Mr. Stephen Cranley, C.E.T  
Supervisor, Distribution Design, ICI & Layouts (North)  
**Phone:** 1-877-963-6900 ext. 31297

**E-mail:** [stephen.cranley@alectrautilities.com](mailto:stephen.cranley@alectrautilities.com)

Mitchell Penner  
Supervisor, Distribution Design-Subdivisions  
**Phone:** 416-302-6215

**Email:** [Mitchell.Penner@alectrautilities.com](mailto:Mitchell.Penner@alectrautilities.com)



LOCATION OF WIRES, CABLES OR CONDUCTORS	SYSTEM VOLTAGE			
	SPAN GUYS AND COMMUNICATIONS WIRES	UP TO 600V AND NEUTRAL	4.16/2.4kV TO 27.6/16kV (SEE NOTE 1)	44kV
MINIMUM VERTICAL CLEARANCES (SEE NOTE 2)				
OVER OR ALONGSIDE ROADS, DRIVEWAYS OR LANDS ACCESSIBLE TO <u>VEHICLES</u>	442cm	442cm	480cm	520cm
OVER GROUND ACCESSIBLE TO <u>PEDESTRIANS AND BICYCLES ONLY</u>	250cm	310cm	340cm	370cm
ABOVE TOP OF RAIL AT <u>RAILWAY CROSSINGS</u>	730cm	730cm	760cm	810cm

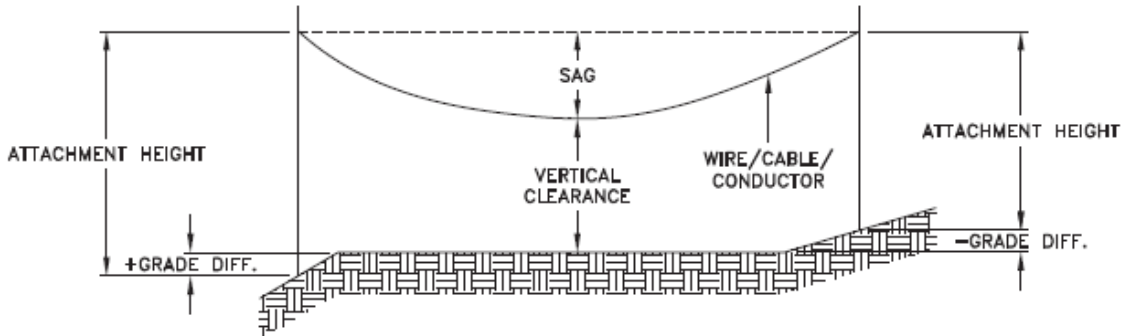

MINIMUM ATTACHMENT HEIGHT = MAXIMUM SAG  
 + MINIMUM VERTICAL CLEARANCE (FROM ABOVE TABLE)  
 ± GRADE DIFFERENCE  
 + 0.3m (VEHICLE OR RAILWAY LOCATION)  
 + SNOW DEPTH (PEDESTRIAN LOCATION, SEE NOTE 3)

**NOTES:**

1. THE MULTIGROUNDED SYSTEM NEUTRAL HAS THE SAME CLEARANCE AS THE 600V SYSTEM.
2. THE VERTICAL CLEARANCES IN THE ABOVE TABLE ARE UNDER MAXIMUM SAG CONDITIONS.
3. REFER TO CSA STANDARD C22.3 No.1, ANNEX D FOR LOCAL SNOW DEPTH VALUES.
4. ALL CLEARANCES ARE IN ACCORDANCE TO CSA STANDARD C22.3.

**CONVERSION TABLE**

METRIC	IMPERIAL (APPROX)
810cm	27'-0"
760cm	25'-4"
730cm	24'-4"
520cm	17'-4"
480cm	16'-0"
442cm	15'-5"
370cm	12'-4"
340cm	11'-4"
310cm	10'-4"
250cm	8'-4"

**REFERENCES**

SAGS AND TENSIONS | SECTION 02

**MINIMUM VERTICAL CLEARANCES OF WIRES, CABLES AND CONDUCTORS ABOVE GROUND OR RAILS**

ORIGINAL ISSUE DATE: 2010-DEC-24 REVISION NO: R1 REVISION DATE: 2012-JAN-09

Certificate of Approval	
This construction Standard meets the safety requirements of Section 4 of Regulation 22/04	
Joe Crozier, P.Eng.	2012-JAN-09
Name	Date
P.Eng. Approval By:	Joe Crozier

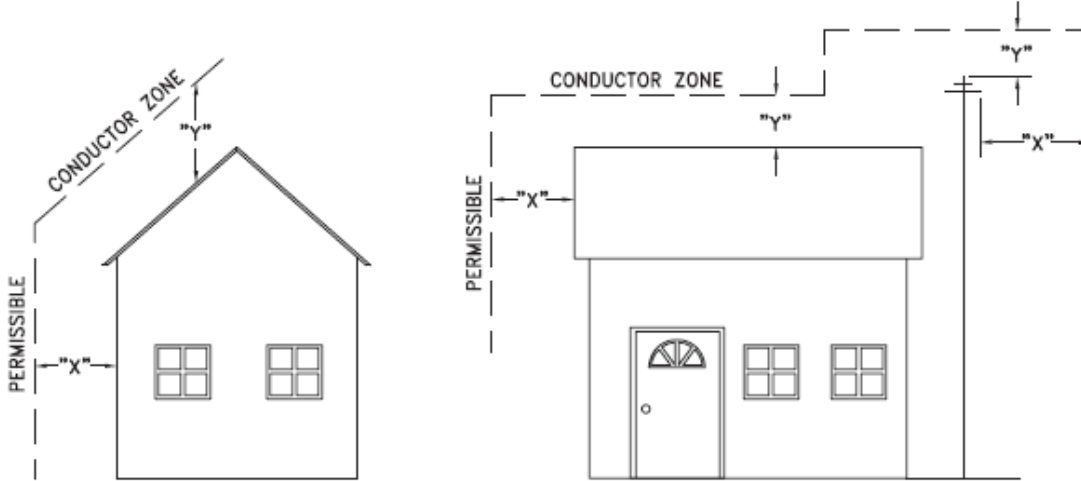

VOLTAGE	MINIMUM HORIZONTAL CLEARANCE UNDER MAXIMUM SWING CONDITIONS DIMENSION "X" (SEE NOTES 1, 3 & 4)	MINIMUM VERTICAL CLEARANCE UNDER MAXIMUM DESIGN SAG CONDITIONS DIMENSION "Y" (SEE NOTES 1, 2, 4 & 5)
0-600V AND NEUTRAL	100cm	250cm
4.16/2.4 TO 44kV	300cm	480cm

**NOTES**

1. UNDER NO CIRCUMSTANCES SHALL A CONDUCTOR BE PERMITTED TO PENETRATE THE ENVELOPE SHOWN BY THE DOTTED LINE.
2. THE VERTICAL CLEARANCES ARE UNDER CONDITIONS OF MAXIMUM DESIGN SAG.
3. THE HORIZONTAL CLEARANCES ARE UNDER CONDITIONS OF MAXIMUM SWING. WHERE THE CONDUCTOR SWING IS NOT KNOWN A HORIZONTAL CLEARANCE OF 480CM SHALL BE USED.
4. BUILDINGS THAT EXCEED 3 STOREYS OR 15M IN HEIGHT, THE MINIMUM HORIZONTAL CLEARANCE OF THE SECONDARY CONDUCTORS SHOULD BE INCREASED TO 300cm WHERE IT IS NECESSARY TO ALLOW FOR THE RAISING OF LADDERS BY LOCAL FIRE DEPARTMENTS.
5. IN SITUATIONS SUCH AS MULTI-LEVEL GARAGES, WHERE ROOFS ARE NORMALLY USED BY PERSONS AND VEHICLES, THE VERTICAL CLEARANCES OF POWERSTREAM STANDARD 03-1 SHALL APPLY.
6. DISTRIBUTION LINES CONSTRUCTED NEAR BUILDINGS SHALL BE BUILT TO AVOID OVERHANG WHEREVER POSSIBLE. WHERE LINES MUST BE CONSTRUCTED OVER OR ADJACENT TO BUILDINGS THE APPLICABLE HORIZONTAL AND VERTICAL CLEARANCES SHALL BE AT CONDITIONS OF MAXIMUM CONDUCTOR SWING AND MAXIMUM SAG. THE ABOVE CLEARANCES ARE DESIGNED TO PREVENT PERSONS ON OR IN BUILDINGS AS WELL AS EXTERNAL MACHINERY USED IN CONJUNCTION WITH A BUILDING TO COME IN CONTACT WITH CONDUCTORS. EFFORTS SHOULD BE MADE TO INCREASE THESE CLEARANCES WHERE POSSIBLE.
7. ALL CLEARANCES ARE IN ACCORDANCE TO CSA C22.3 NO.1-06 (TABLE-9).

METRIC	IMPERIAL (APPROX)
480cm	16'-0"
300cm	10'-0"
250cm	8'-4"
100cm	3'-4"

**MINIMUM VERTICAL & HORIZONTAL CLEARANCES OF CONDUCTORS FROM BUILDINGS OR OTHER PERMANENT STRUCTURES (CONDUCTORS NOT ATTACHED TO BUILDINGS)**

**Certificate of Approval**  
This construction Standard meets the safety requirements of Section 4 of Regulation 22/04  
Debbie Dadwani, P.Eng. 2010-MAY-05  
Name Date  
P. Eng. Approval By: *D. Dadwani*

ORIGINAL ISSUE DATE: 2010-MAY-05 REVISION NO: REVISION DATE:  
PS:\System Planning and Standards\Standard Design\PowerStream Standards\PowerStream Standards working files\Section 3-1-02\WG 03-4 R0 May 5, 2010.dwg, 5/5/2010 10:22:02 AM, Adobe PDF

**To:** Committee of Adjustment  
**From:** Lindsay Haviland, Building Standards Department  
**Date:** March 28, 2023  
**Applicant:** Linda Holt  
**Location:** 56 Netherford Road  
 PLAN RP5590 Lot 57  
**File No.(s):** A026/23

**Zoning Classification:**

The subject lands are zoned R1E(EN) – First Density Residential Zone (Established Neighbourhood) and subject to the provisions of Exception 14.534 under Zoning By-law 001-2021, as amended.

#	Zoning By-law 001-2021	Variance requested
1	A maximum lot coverage of 23% is required [Table 7-3].	To permit a maximum lot coverage of 27.45%
2	A maximum height of 8.5 metres is required [Section 4.5.1.b.]	To permit a maximum height of 9.08 metres for the dwelling.
3	In any Residential zone, the maximum height of a residential accessory structure shall be 3.0 m. [Section 4.1.4.1].	To permit a maximum height of 3.81 metres for a residential accessory structure.

**Staff Comments:**

**Stop Work Order(s) and Order(s) to Comply:**

There are no outstanding Orders on file

**Building Permit(s) Issued:**

Building Permit No. 22-137149 for Single Detached Dwelling - New, Issue Date: (Not Yet Issued)  
 Building Permit No. 22-142966 for Shed/Gazebo - New, Issue Date: (Not Yet Issued)

**Other Comments:**

General Comments	
1	The applicant shall be advised that additional variances may be required upon review of detailed drawing for building permit/site plan approval.

**Conditions of Approval:**

If the committee finds merit in the application, the following conditions of approval are recommended.

\* Comments are based on the review of documentation supplied with this application.

**To:** Christine Vigneault, Committee of Adjustment Secretary Treasurer  
**From:** Nancy Tuckett, Director of Development Planning  
**Date:** April 11, 2023  
**Name of Owner:** Linda Holt  
**Location:** 56 Netherford Road  
**File No.(s):** A026/23

---

**Proposed Variance(s) (By-law 01-2021):**

- 1) To permit a maximum lot coverage of 27.45%
- 2) To permit a maximum height of 9.08 m for the dwelling.
- 3) To permit a maximum height of 3.81 m for a residential accessory structure.

**By-Law Requirement(s) (By-law 01-2021):**

- 1) A maximum lot coverage of 23% is required. [Table 7-3]
- 2) A maximum height of 8.5 m is required. [Section 4.5.1.b.]
- 3) In any residential zone, the maximum height of a residential accessory structure shall be 3 m. [Section 4.1.4.1]

**Official Plan:**

Vaughan Official Plan 2010 ('VOP 2010'): "Low-Rise Residential"

**Comments:**

The Owner is requesting permission to demolish an existing one-storey dwelling and construct a two-storey dwelling with the above noted variances in an established large-lot neighbourhood.

At the request of the Development Planning Department, the Owner has maintained a maximum building height of 9.08 m that is consistent with the existing dwelling on-site (9.81 m) and reduced the maximum lot coverage to 27.45% to ensure the scale of built form remains compatible with other new development in the immediate neighbourhood. The proposed two-storey dwelling (with garage) occupies 20.74%, while the remaining 6.71% is associated with the proposed front/rear porch and cabana. Planning staff have no objection to Variances 1 and 2, as it facilitates a development that preserves the character of the neighbourhood. With respect to Variance 3, the increase in maximum height for the residential accessory structure (cabana) is reasonable given its spacious setbacks and surrounding vegetation that helps mitigate any massing implications. It should also be noted the height relief only applies to the centre gable; the two ends, which have flat roofs, comply with the By-law.

In support of this minor variance application the Owner submitted an Arborist Report and Tree Preservation Plan, prepared by Welwyn Consulting, dated on February 22, 2022. Urban Design staff reviewed the material and are satisfied with its findings.

The Development Planning Department is of the opinion that the requested Variances are minor in nature, maintain the general intent and purpose of the Official Plan and Zoning By-law, and are desirable for the appropriate development of the land.

**Recommendation:**

The Development Planning Department recommends approval of the application.

**Conditions of Approval:**

If the Committee finds merit in the application, the following condition of approval is recommended:

None

**Comments Prepared by:**

Roberto Simbana, Planner  
David Harding, Senior Planner